

**SECTION 2-10
POWERPLANT**

TABLE OF CONTENTS

	Block	Page
Index	2-10-00	..01
General	2-10-05	..01
Main Assemblies	2-10-05	..02
Fan Module	2-10-05	..02
High-pressure Compressor	2-10-05	..02
High-pressure Turbine (HPT)	2-10-05	..02
Low-pressure Turbine (LPT).....	2-10-05	..02
Exhaust Cone and Mixer	2-10-05	..02
Accessory Gearbox	2-10-05	..03
Engine Fuel System	2-10-10	..01
Fuel Pump and Metering Unit (FPMU)	2-10-10	..01
Fuel Cooled Oil Cooler (FCOC).....	2-10-10	..02
Compressor Variable Geometry Actuation System	2-10-10	..02
Fuel Nozzles	2-10-10	..02
Lubrication System.....	2-10-15	..01
Lubricating Oil Supply System.....	2-10-15	..01
Oil Tank	2-10-15	..01
Lube and Scavenge Pump	2-10-15	..02
Oil Filter Unit	2-10-15	..02
Air-Cooled Oil Cooler (ACOC)	2-10-15	..02
Fuel-Cooled Oil Cooler (FCOC).....	2-10-15	..02
Engine Sumps	2-10-15	..03
Lubricating Oil Scavenge System.....	2-10-15	..03
Lubricating Oil Vent System	2-10-15	..03
Engine Bleed.....	2-10-20	..01
Engine Electrical System	2-10-25	..01
Electrical Power Sources.....	2-10-25	..01
Permanent Magnet Alternator (PMA)	2-10-25	..01
Ignition System.....	2-10-30	..01
Pneumatic Starting System.....	2-10-30	..02
Air Turbine Starter (ATS).....	2-10-30	..02
Starting Control Valve (SCV).....	2-10-30	..02
Starting By Using Ground Equipment.....	2-10-30	..03

AOM-145/1114



Engine Indicating System (EIS).....	2-10-35..	01
Engine Sensors	2-10-35..	01
Pressure/Temperature Transducer Sensor	2-10-35..	01
Low Oil-Pressure Sensor	2-10-35..	01
Oil-Level and Low-Level System	2-10-35..	01
Electrical Oil-Filter Impending-Bypass Indicator	2-10-35..	01
Fuel Temperature Sensor	2-10-35..	02
Electrical Fuel-Filter Impending-Bypass Indicator	2-10-35..	02
Magnetic Indicating Plug	2-10-35..	02
Igniter Spark-Rate Detector	2-10-35..	02
Vibration Sensors	2-10-35..	02
Fuel Flowmeter	2-10-35..	02
Powerplant Control System	2-10-40..	01
Full Authority Digital Electronic Control (FADEC)	2-10-40..	01
N1TARGET Calculation.....	2-10-40..	04
N1REQUEST Calculation.....	2-10-40..	04
Ground/Flight Idle Thrust Schedule	2-10-40..	05
Closed-Loop Fan Speed Control	2-10-40..	05
N1/N2 Overspeed/Underspeed Protection	2-10-40..	06
Interstage-Turbine Temperature (ITT) Limiting	2-10-40..	06
Acceleration/Deceleration Limiting	2-10-40..	06
Flameout Detection/Autorelight	2-10-40..	06
N1 Reversionary Control Mode.....	2-10-40..	07
FADEC Inputs Selection and Fault Accommodation	2-10-40..	07
FADEC Discrete Outputs.....	2-10-40..	07
Alternate FADEC Selection.....	2-10-40..	08
FADEC Reset	2-10-40..	08
Engine Operation.....	2-10-50..	01
General	2-10-50..	01
Thrust Ratings	2-10-50..	01
Engine Control	2-10-50..	02
Thrust Management.....	2-10-50..	02
Thrust Mode Selection	2-10-50..	02
Fan-Speed Scheduling.....	2-10-50	08
Alternate Takeoff Thrust Control System (ATTCS)	2-10-50..	10
Takeoff Data Setting	2-10-50..	11
Engine Start	2-10-50..	14
Engine Dry Motoring.....	2-10-50..	15
Engine Shutdown.....	2-10-50..	15
EICAS Messages	2-10-50..	16



AIRPLANE OPERATIONS MANUAL

POWERPLANT

Controls and Indicators	2-10-60 ..01
Control Pedestal	2-10-60 ..01
Powerplant Control Panel.....	2-10-60 ..03
Fire Handle	2-10-60 ..05
Engine Indication on EICAS	2-10-60 ..05
Takeoff Page on MFD	2-10-60 ..10
First Engine Backup Page on RMU.....	2-10-60 ..12
Thrust Reverser (*)	2-10-70 ..01
General.....	2-10-70 ..01
Lock Protection.....	2-10-70 ..01
Operation.....	2-10-70 ..01
Operation Logic.....	2-10-70 ..02
EICAS Indication.....	2-10-70 ..02
Thrust Reverser Interlock.....	2-10-70 ..03
EICAS Messages	2-10-70 ..03

AOM-145/1114

NOTE: Optional equipment are marked with an asterisk (*) and its description may not be present in this manual.

DECEMBER 20, 2002

2-10-00	Page 3	Code 01
---------	-----------	------------

**AIRPLANE
OPERATIONS
MANUAL**



THIS PAGE IS LEFT BLANK INTENTIONALLY

2-10-00	Page 4	Code 01
---------	-----------	------------

DECEMBER 20, 2002

ACM-145/1114

GENERAL

The airplane is powered by two fuselage-mounted Rolls-Royce turbofan engines. Engine denominations, thrust (installed, static sea level) and flat rates are as follows:

ENGINE	MODEL	MAX. T/O THRUST	FLAT RATE
AE3007A	EMB-145	7426 lb	ISA+15°C
AE3007A1/1	EMB-145	7426 lb	ISA+15°C
AE3007A1	EMB-145	7426 lb	ISA+30°C
AE3007A1P	EMB-145	8169 lb	ISA+19°C
AE3007A1E	EMB-145	8810 lb	ISA+19°C
AE3007A3	EMB-135	7057 lb	ISA+15°C
AE3007A1/3	EMB-135	7426 lb	ISA+30°C

NOTE: - Max T/O thrust and flat rate values for AE3007A1P and AE3007A1/3 are based on T/O RSV thrust.
 - Max T/O thrust and flat rate values for AE3007A1E are based on E T/O RSV thrust.

The AE3007 is a high bypass ratio, two-spool axial flow turbofan engine. The main design features include:

- A single stage fan,
- A 14-stage axial-flow compressor with inlet guide vanes and five variable-geometry stator stages,
- A 2-stage high pressure turbine to drive the compressor,
- A 3-stage low pressure turbine to drive the fan,
- Dual, redundant, Full Authority Digital Electronic Controls (FADEC),
- Accessory gearbox,
- Air system for aircraft pressurization and engine starting.

Each engine is controlled by redundant FADECs. The FADECs also provide information to the EICAS, although some parameters signals are provided directly from engine sensors. All powerplant parameters are indicated on the EICAS, which also provides warning, caution and advisory messages.

The cockpit control stand incorporates two thrust levers, one for each engine, and four buttons for engine thrust rating selection.

Controls for ignition, FADEC, takeoff data setting, takeoff rating selection and engine Start/Stop are located on the overhead panel.

MAIN ASSEMBLIES

FAN MODULE

Air enters the engine through the fan case inlet and is compressed by a 24-blade, single-stage fan. The compressed air is split into a bypass stream, which bypasses the core through the outer bypass duct, and a core stream that enters the high-pressure compressor.

HIGH-PRESSURE COMPRESSOR

The compressor rotor consists of 14 stages of individual wheel assemblies, compressor shaft, compressor-to-turbine shaft, and compressor tiebolt. Compressor Variable Geometry (CVG) stators are provided for stages 1 through 5 and for the inlet guide vanes. These stators are driven by servo actuators controlled by the FADECs. High-pressure compressor bleed air tapplings are available at the 9th and 14th stages (compressor discharge).

A combustion liner assembly mixes air and fuel to support combustion, and delivers a uniform, high-temperature gas flow to the turbine.

HIGH-PRESSURE TURBINE (HPT)

The High Pressure Turbine converts the gas flow coming from the combustion liner into usable mechanical energy to drive the compressor.

LOW-PRESSURE TURBINE (LPT)

The Low-Pressure Turbine is located downstream of the High-Pressure Turbine and extracts energy from the gas path to drive the fan. The LPT is connected to the fan by means of a shaft extending through the entire high-pressure spool and the compressor assembly. Air exiting the LPT mixes with the bypass air and provides thrust.

EXHAUST CONE AND MIXER

The forced air mixer provides the mixing for the engine bypass and core gas-flow streams and sets the fan operating line for all operating envelope conditions. The Thrust Reversers deflect the exhaust providing reverse thrust.

ACCESSORY GEARBOX

An accessory gearbox is driven by the high-pressure spool and provides driving pads for the following engine and airplane accessories:

- Engine accessories: Fuel Pump and Metering Unit (FPMU), Permanent Magnet Alternator (PMA), and oil pump.
- Airplane accessories: hydraulic pump, electrical generators, and pneumatic starter.

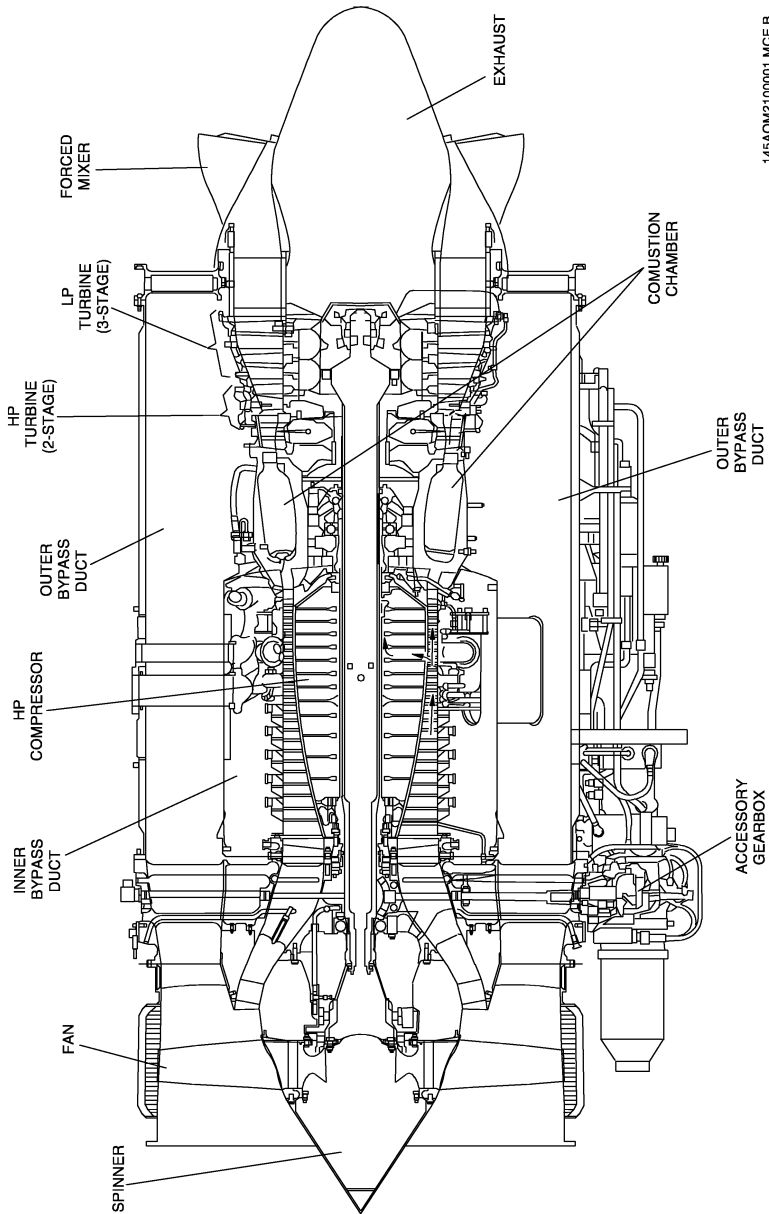

145AOM2100001.MCE B

ROLLS-ROYCE AE 3007 ENGINE

2-10-05	Page 4	Code 01
---------	-----------	------------

DECEMBER 20, 2002

AOM-145/1114

ENGINE FUEL SYSTEM

The Engine Fuel System has a distribution and an indicating system. The distribution system supplies filtered and metered fuel for combustion. Secondary functions include providing pressurized fuel to activate the Compressor Variable Geometry (CVG) system, and providing a cooling medium for lubrication oil. The indicating system components monitor the fuel supply and are located on the engines.

The engine fuel system comprises a Fuel Pump and Metering Unit (FPMU), a Fuel Cooled Oil Cooler (FCOC), a Compressor Variable Geometry (CVG) actuator and fuel nozzles.

FUEL PUMP AND METERING UNIT (FPMU)

The FPMU is an electrical-mechanical, fully-integrated line replaceable unit which incorporates the engine fuel pumping, filtering, and metering functions, and operates under authority of the engine FADECs. The FPMU controls and supplies fuel to the engine nozzles at correct pressure and flow rate for engine start, correct engine operation, engine stop, and also controls the compressor variable-geometry vanes.

The pump system contains a low-pressure centrifugal pump and a high-pressure gear pump. The centrifugal pump raises the pressure of incoming fuel high enough to meet the inlet pressure requirements of the high-pressure pump, with allowances for pressure losses in the fuel filter and the FCOC. The centrifugal pump also provides vapor-free fuel to the gear pump.

The main fuel filter, located upstream of the gear pump, protects the pump metering unit components and fuel nozzles from fuel contaminants. A fuel flow bypass valve allows continued operation in the event of complete filter blockage.

A fuel flow pressure relief valve across the pump protects the fuel system from overpressure conditions.

An air vent valve provides automatic venting of entrapped air or fuel vapor at the gear pump discharge during engine starting and/or motoring. The vent valve remains closed whenever the vent solenoid is not energized, thus preventing fuel leakage through the vent system if the airplane boost pumps are turned on while the engine is not running.

The fuel-metering valve is controlled by the FADEC and controls fuel distribution from the gear pump to the engine fuel nozzles.

Downstream of the metering valve, a pressurizing valve (PRV) generates adequate system pressure for the proper functioning of the main metering valve and pressure drop servos and CVG hydraulic actuator. The PRV also provides the primary means for engine fuel shutoff, commanded through the Latching Shutoff Valve, that receives a Stop input from the cockpit through the FADEC.

FUEL-COOLED OIL COOLER (FCOC)

The FCOC is installed externally on the bottom of the outer bypass duct, aft region. Fuel flows from the FPMU's centrifugal pump to the FCOC where it simultaneously cools the engine's lubrication oil and warms the fuel. A thermal/pressure bypass valve bypasses oil flow to prevent fuel leaving the FCOC from being heated above 93.3°C (200°F). The oil is also bypassed if the differential oil pressure is greater than 50 psi due to hung or cold starts. After the FCOC, the fuel goes to the filter.

COMPRESSOR VARIABLE GEOMETRY (CVG) ACTUATION SYSTEM

The high-pressure compressor has a variable geometry vane system on its five stages to provide maximum engine performance over a wide range of engine speeds. The FADEC contains a schedule of vane positions versus corrected gas generator speed (N₂) that has been selected to provide the optimum compressor efficiency of steady-state conditions and adequate stall margins during transients.

The FADEC senses the vane position and, by means of fuel pressure from the FPMU, commands the CVG actuator movement to position the compressor-inlet guide vanes and the first five rows of compressor vanes to the desired setting.

FUEL NOZZLES

Each engine has 16 fuel nozzles, that furnish atomized fuel to the combustor at the proper spray angle and pattern, for varying airflow conditions.

2-10-10	Page 2	Code 01
---------	-----------	------------

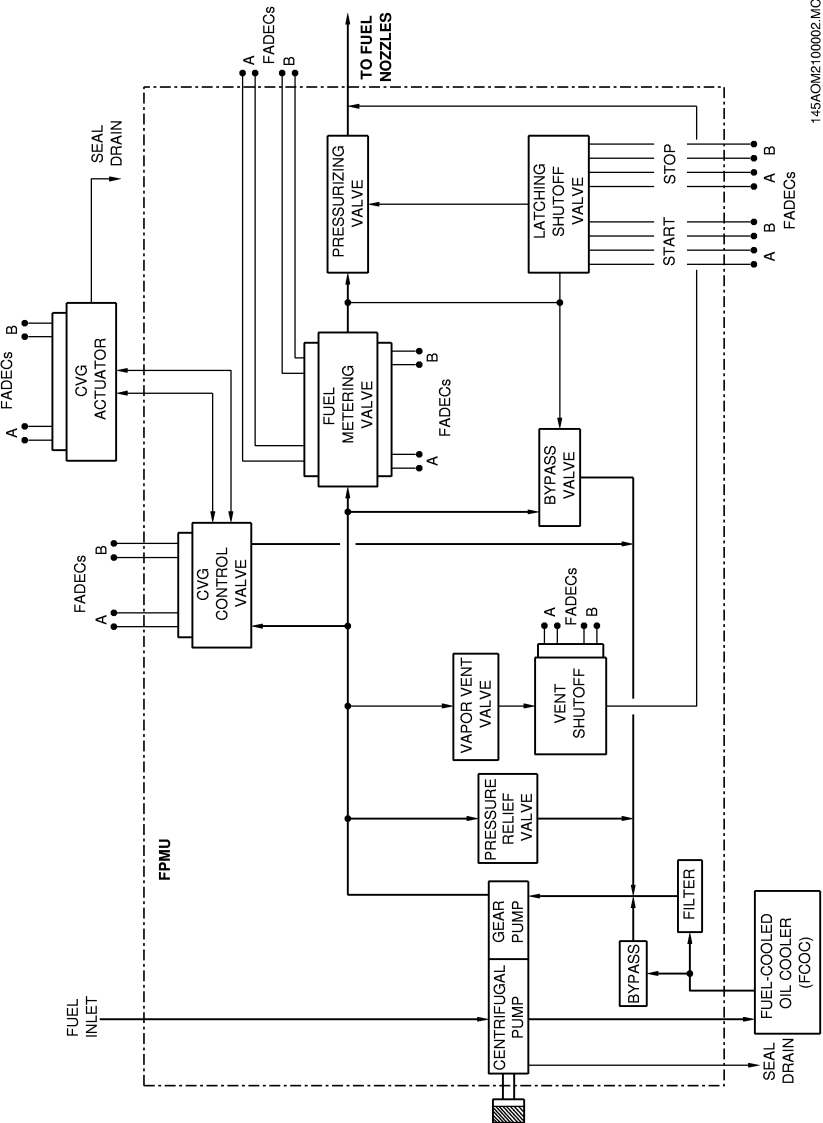

145AOM2100002.MCE

AOM-145/1114

ENGINE FUEL SYSTEM SCHEMATIC

JUNE 28, 2002

2-10-10	Page 3	Code 01
---------	-----------	------------

**AIRPLANE
OPERATIONS
MANUAL**



THIS PAGE IS LEFT BLANK INTENTIONALLY

2-10-10	Page 4	Code 01
---------	-----------	------------

JUNE 28, 2002

ACM-145/1114

LUBRICATION SYSTEM

The engine lubrication system is a self-contained, pressure-regulated and recirculating dry sump system. The system supplies filtered and pressurized oil to the various engine oil coolers, engine sumps and the accessories gearbox, at the proper temperature, to cool and lubricate the bearings, seals, and gear meshes.

The main subsystems of the oil system are: lubricating oil-supply, engine sumps, lubricating oil scavenge and lubricating oil vent.

LUBRICATING OIL-SUPPLY SYSTEM

Oil is supplied to the lube and scavenge pump from a pressurized oil tank and is pumped through an oil filter. The oil is then cooled while passing through two heat exchangers (ACOC and FCOC). Oil pressure is controlled by a pressure-regulating valve in the pump housing. A tank pressurizing valve maintains positive pressure in the oil tank to ensure an adequate oil supply to the lube and scavenge pump, and proper oil pressure at altitude. A separate Tank Vent Valve protects the tank from over-pressurization. Oil to the accessory gearbox is distributed through cast passages to the various gear meshes and bearings. Pressurized oil is divided inside the front frame and routed to the fan and front sumps. An external tube delivers oil from the front frame to the compressor diffuser and the rear turbine-bearing support.

The main components of this subsystem are as follows: oil tank, lube and scavenge pump, oil filter unit, air-cooled oil cooler (ACOC) and fuel-cooled oil cooler (FCOC).

OIL TANK

The oil tank is designed to store a sufficient amount of oil (12 quarts) for lubrication of the engine and the accessory gearbox. The tank has an oil level sight gage and an oil level/low level warning sensor. These sensors allow the oil level to be continuously read remotely, and includes a switch that is actuated when there are 5 quarts or less of usable oil remaining in the tank. A screen on the oil outlet and a chip collector plug at the tank bottom are protective devices that prevent debris from recirculating. The tank is protected from over-pressurization by the externally vented Pressure Relief Valve.

LUBE AND SCAVENGE PUMP

The pressure and scavenge pumps are all mounted in a single integral unit. A single shaft drives six pumping elements. One pressure pumping element pumps oil from the tank to the system and five scavenge pumping elements pump oil from the sumps and the gearbox to the oil tank. The pump assembly also includes a pressure regulating valve which controls oil pressure. Main Oil Pressure varies with center sump air pressure. A line connecting one side of the regulating valve to the center sump enables the regulating valve to compensate for the air pressure inside the sump.

OIL FILTER UNIT

The filter unit includes a replaceable filter element, and mechanical and electrical impending-bypass indicators. A bypass valve opens and allows oil to bypass the filter during cold starts, or when the filter becomes excessively contaminated. A screen is located in the bypass inlet to prevent passage of particles. The electrical impending-bypass indicator provides the remote monitoring of the system.

AIR-COOLED OIL COOLER (ACOC)

The ACOC is a surface-type heat exchanger with a single plate-fin oil section. Filtered, pressurized oil enters a manifold and flows through the air-cooled heat exchanger. A thermal/pressure bypass valve senses ACOC outlet temperature. When open, this valve allows cold oil to bypass the ACOC and, once closed, forces hot oil to flow through the cooler. The bypass valve also opens if the cooler is obstructed.

FUEL-COOLED OIL COOLER (FCOC)

The FCOC is a heat exchanger that simultaneously cools the engine lubrication oil and warms the fuel upstream of the FPMU filter. A thermal/pressure bypass valve prevents fuel overheat. This valve also opens in case of cooler obstruction or cold starts.

2-10-15	Page 2	Code 01
---------	-----------	------------

ENGINE SUMPS

There are four engine sumps that encompass five main-shaft bearings, four bevel-gear bearings, and six carbon seals. These sumps are as follows: fan sump, front sump, center sump and aft sump.

LUBRICATING OIL SCAVENGE SYSTEM

Air and oil are removed from each of the sumps and directed to individual scavenge inlets on the oil pump. The scavenge section of the pump includes five pumping elements and has separate inlets for each of the engine sumps and the accessory gearbox. Each of the sump inlets to the pump includes a debris monitor with magnetic chip collector and screen in order to protect the pumping elements. The gearbox sump inlet to the pump contains only a screen.

LUBRICATING OIL VENT SYSTEM

All the engine sumps are vented to the accessory gearbox. The oil tank also vents to the gearbox through a core-external line that contains a tank-pressurizing valve. A Tank Vent Valve is located upstream of the pressurizing valve and is vented to the atmosphere.

The gearbox acts as an air/oil separator removing any oil contained in the vent air. The air vented by the gearbox breather is conducted through a transfer tube and dumped to the core exhaust.

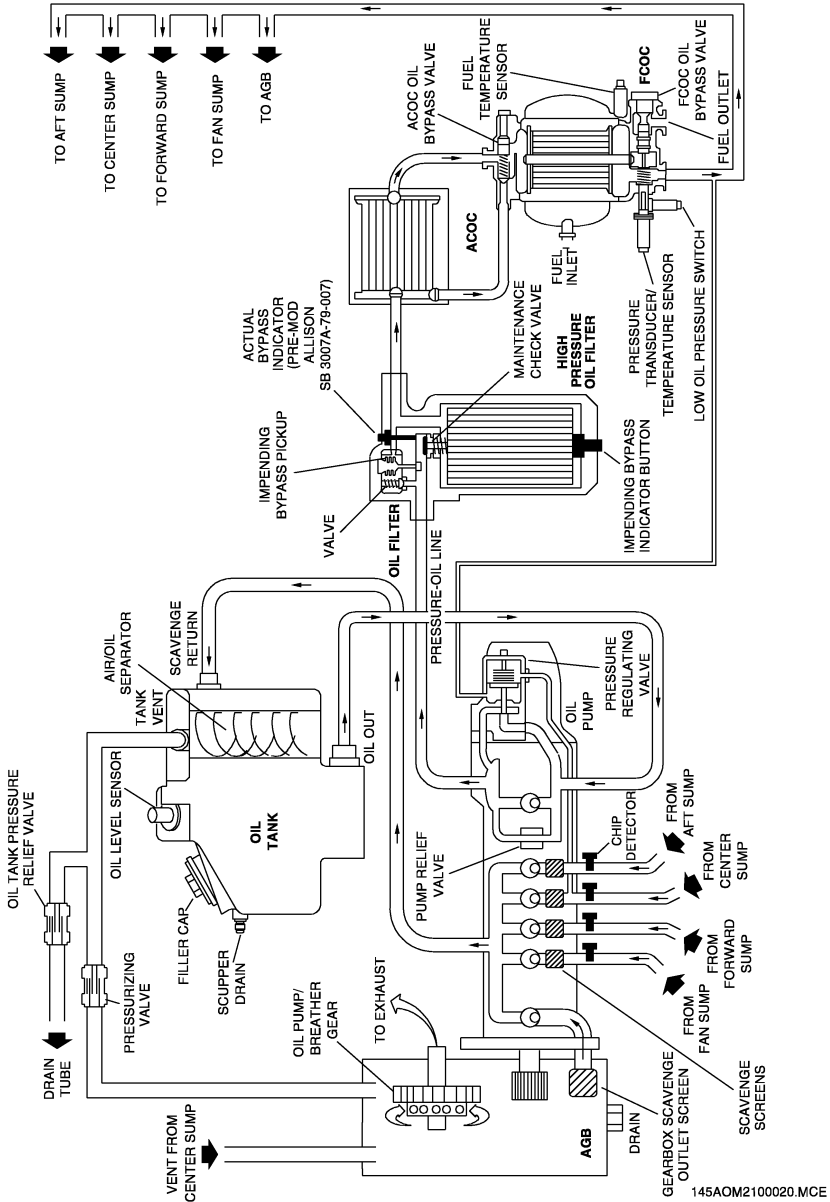

LUBRICATION SYSTEM SCHEMATIC

2-10-15	Page 4	Code 01
---------	-----------	------------

DECEMBER 20, 2002

ENGINE BLEED

Air is bled from the compressor 9th stage during engine starting to assist with accelerating to idle rpm.

There are two different types of compressor acceleration bleed valves (CABV). The original type used two valves per engine, located externally on the HP compressor at approximately the 12:00 and 6:00 O'clock positions. The second type is a single valve at 6:00 O'clock position.

The engine also provides bleed air to the Pressurization and Air Conditioning system through the Engine Bleed Valve (EBV). Bleed air for this system is extracted from the 9th or 14th stages depending on the request. Refer to section 2-14-05 for more information.

**AIRPLANE
OPERATIONS
MANUAL**



THIS PAGE IS LEFT BLANK INTENTIONALLY

2-10-20	Page 2	Code 01
---------	-----------	------------

JUNE 28, 2002

AOM-145/1114

ENGINE ELECTRICAL SYSTEM

ELECTRICAL POWER SOURCES

Primary electrical power for engine control and the ignition system is provided by a permanent magnet alternator (PMA) that is driven by the engine accessory gearbox. Before the PMA attains sufficient speed to generate electrical power, the airplane 28 V DC system is used to power the FADEC. Aircraft 28 V DC is also used to energize a fail-safe ignition relay, so that in the event of aircraft power loss the ignition is turned on and the air vent valve is closed, thus preventing fuel leakage through the vent port.

The PMA is the only source of power for the igniters. If a PMA failure occurs there will not be any spark from the igniters.

PERMANENT MAGNET ALTERNATOR (PMA)

The PMA provides electrical power for both engine FADECs and to the redundant ignition systems.

The PMA provides sufficient power to drive the ignition system at all speeds above 10% N₂, and powers the FADECs at a minimum of 50% N₂. The PMA also provides power to the Thrust Rating Mode Buttons, in case of electrical emergency.

For starting and emergency backup, the engine control system requires aircraft supplied 28 V DC (GPU and/or batteries) power.

**AIRPLANE
OPERATIONS
MANUAL**



THIS PAGE IS LEFT BLANK INTENTIONALLY

2-10-25	Page 2	Code 01
---------	-----------	------------

JUNE 28, 2002

ACM-145/1114

IGNITION SYSTEM

The engine has a dual redundant ignition system composed of two ignition exciters, two high-tension igniter leads and two igniters.

The ignition system is turned on by the FADEC during engine starting cycle or when an engine flameout condition is detected (auto-relight).

Each ignition exciter is controlled by a separate FADEC and powered by a separate electrical winding of the PMA.

Continuous ignition or ignition off can be manually selected through the Ignition Selector Knob, located on the Powerplant Control Panel and connected to the FADECs. Ignition control is performed according to Ignition Selector Knob position, as follows:

- Ignition Selector Knob set to ON:
 - Both FADECs command associated ignition channel during start, as soon as the PMA provides sufficient power.
 - The ignition is not automatically deactivated when the start cycle is completed.
 - If the engine is already running, both FADECs activate their ignition channels.
- Ignition Selector Knob set to AUTO:
 - During ground start, only the FADEC in control activates the ignition system at the proper time. The engine start will be performed with only one exciter. The exciters will be alternately selected for each subsequent ground start.
 - The FADEC deactivates the ignition system when the engine starting cycle is completed.
 - The auto-relight function activates the ignition system.
- Ignition Selector Knob set to OFF:
 - If the engine is not running, the FADEC neither activates the ignition system nor actuates the engine fuel valve from closed to open position.
 - If the engine is already running, at least in IDLE thrust, the FADEC does not close the engine fuel valve.

PNEUMATIC STARTING SYSTEM

The engine starting system comprises the Air Turbine Starter and the Starting Control Valve. The starting system has the function of supplying airflow for pneumatic engine starting, converting the pneumatic energy into gearbox driving torque.

Pneumatic power source can be selected from the APU, ground air supply source, or cross bleed from the opposite engine.

AIR TURBINE STARTER (ATS)

The ATS is installed in a dedicated engine accessory gearbox pad and consists basically of an air inlet, an impeller turbine, a reduction gearset, a clutch, and an output shaft.

The ATS converts pneumatic energy into driving torque for engine gas generator spool acceleration up to the self-sustained speed during the starting cycle. The air exhaust from the turbine is discharged into the engine nacelle compartment.

STARTING CONTROL VALVE (SCV)

The SCV regulates the pressure supplied to the ATS and provides isolation from the pneumatic system following start completion. The valve is electrically controlled and pneumatically actuated.

A SCV visual position indication is available on the valve housing.

A manual override adapter is available on the valve housing, enabling engine start in the case of a valve or associated electrical system failure. The valve is spring-loaded to the closed position.

If the ATS shutoff valve remains open after 53% N₂, a caution message is presented on the EICAS.

STARTING BY USING GROUND EQUIPMENT

The system is pressurized by a pneumatic ground equipment connected to start the engine 2.

The SCV energizes to open when a starting switch ground signal energizes the engine 2 start relay.

When the engine gas generator attains 53% N2, a validation time of 10 seconds elapses before the message "E2 ATS SOV OPN" appears on the EICAS. At 54.6% N2 the FADEC sends a signal to engine 2 start relay be de-energized, thus the SCV is also de-energized and the airflow stops flowing to the ATS turbine. In normal operation conditions, 54.6% N2 is reached in less than 10 seconds.

The ATS turbine stops operating and the engine gas generator speed increases.

**AIRPLANE
OPERATIONS
MANUAL**



THIS PAGE IS LEFT BLANK INTENTIONALLY

2-10-30	Page 4	Code 01
---------	-----------	------------

JUNE 28, 2002

ACM-145/1114

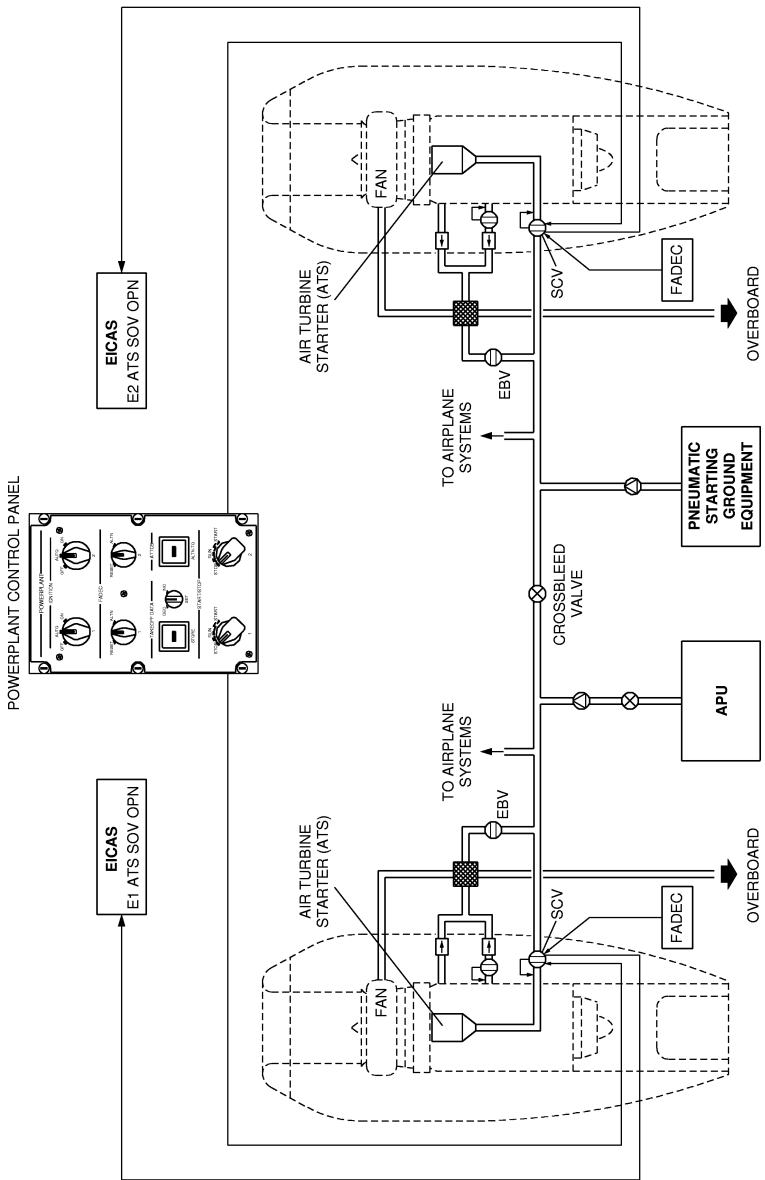

145AOM2100021.MCE

PNEUMATIC STARTING SYSTEM SCHEMATIC

AOM-145/1114

JUNE 28, 2002

2-10-30	Page 5	Code 01
---------	-----------	------------

**AIRPLANE
OPERATIONS
MANUAL**



THIS PAGE IS LEFT BLANK INTENTIONALLY

2-10-30	Page 6	Code 01
---------	-----------	------------

JUNE 28, 2002

ACM-145/1114

ENGINE INDICATING SYSTEM (EIS)

The EIS is composed of a wiring harness and a set of engine-mounted sensors. This system is directly connected to the EICAS, providing real time monitoring of the engine oil, fuel, and mechanical systems.

ENGINE SENSORS

PRESSURE/TEMPERATURE TRANSDUCER SENSOR

This sensor combines engine oil and temperature transducers in a single housing, mounted on the Fuel-Cooled Oil Cooler (FCOC). The pressure and temperature transducers are electrically independent and require separate signal conditioning.

Due to the characteristic of some pressure sensors, the EICAS may display approximately 90 psi for a 2 minutes period, for actual pressures between 90.5 and 155 psi. Considering this characteristic, pressure indication may jump suddenly from approximately 90 psi to the actual pressure value, after the 2 minutes period is expired.

LOW OIL-PRESSURE SENSOR

The function of the low oil-pressure sensor is to give an indication when oil pressure is low. This sensor is also mounted on the FCOC. A warning message is presented on the EICAS in case of low oil pressure.

OIL-LEVEL AND LOW-LEVEL SENSOR

The engine oil-level sensor is a transducer located in the oil tank that gives continuous and accurate oil level readings from 3 quarts to 12 quarts. The low-level sensor is electrically open with 5 quarts or less of oil remaining in the tank and remains closed otherwise. An indication of oil-level is provided on the Takeoff page on the MFD. The indication turns amber when oil level is at 5 quarts or below.

ELECTRICAL OIL-FILTER IMPENDING-BYPASS INDICATOR

The engine electrical oil-filter impending-bypass indicator is located in the oil-filter assembly. An advisory message is presented on the EICAS if the differential pressure across the oil filter exceeds its set point.



FUEL TEMPERATURE SENSOR

The engine fuel-temperature sensor has an indication range of -54° to 176°C (-65° to 350°F) and is located on the FCOO. A caution message is presented on the EICAS in case of fuel low temperature (below 5°C in the engine).

ELECTRICAL FUEL-FILTER IMPENDING-BYPASS INDICATOR

The engine electrical fuel-filter impending-bypass indicator is located on the engine fuel pump and metering unit (FPMU). An advisory message is presented on the EICAS if the differential pressure across the filter exceeds its set point.

MAGNETIC INDICATING PLUG

The magnetic indicating plug is located in the oil tank. The magnetic plug contacts are normally open and are electrically closed when conductive material bridges the gap between them.

IGNITER SPARK-RATE DETECTOR

The engine igniter spark-rate detectors are outputs from the ignition exciters that indicate that an electric field has collapsed in the exciter circuit. A signal is available for each igniter circuit on the engine.

VIBRATION SENSORS

The engine vibration sensors are accelerometers that detect abnormal fan rotor and turbine rotor vibration. The transducers are connected through the engine wiring harness to the EICAS.

FUEL FLOWMETER

The fuel flowmeter is a turbine, mass flow sensor. A given fuel flow through the sensor causes the turbine to move to a calibrated position, providing a specific voltage output to the Data Acquisition Unit (DAU). The DAU converts the voltage signal from the sensor into a flow-rate value (pounds or kilograms per hour) for cockpit display. The fuel flowmeter is calibrated for a range between 130 to 4300 pph. During some starts, fuel flow may drop to values out of the flowmeter range. In this case a zero fuel flow will be displayed on EICAS for a few seconds.

2-10-35	Page 2	Code 01
---------	-----------	------------

POWERPLANT CONTROL SYSTEM

Each AE 3007A engine series features a dual redundant electronic control system. The main components of the powerplant control system are the Full Authority Digital Electronic Controls (FADECs), the FPMU, the Permanent Magnetic Alternator (PMA), the Control Pedestal and the Powerplant Control Panel.

Thrust management logic schedules a corrected fan speed (N1) based on a signal from the ADC and cockpit, sending it to engine control logic, which controls the engine fuel flow and compressor variable geometry (CVG) to attain the required engine steady-state and transient response.

Engine control logic also incorporates engine protection logic that prevents engine damage attributable to excessive rotor speed at all times, and temperature limits after the engine has completed a start.

FULL AUTHORITY DIGITAL ELECTRONIC CONTROL (FADEC)

Each engine is controlled by one of two FADECs that are named FADEC A and FADEC B. All signals between each FADEC and its respective engine and between the FADECs and the airplane are completely redundant and isolated. This allows either A or B FADEC to control the engine independently.

The FADECs are interconnected by dedicated Cross-Channel Data Links. These buses are used to transmit engine data and FADEC status between the two FADECs.

Each FADEC is connected to one of the two FADECs on the opposite engine via data bus. Across this bus, the FADECs communicate the information necessary to implement thrust reverser interlock and Automatic Takeoff Thrust Control System (ATTCS).

Airplane electrical power is fed to the FADEC for engine start as a sole power source until N2 is approximately 50%. Primary electrical power source for each FADEC is generated by a dedicated set of windings in the permanent magnet alternator (PMA). The airplane power source is fed the FADEC as a backup in the event of a failure in the PMA. In the event of total loss of airplane power the pilot would control the engine normally.

Each FADEC receives command signals from the Control Pedestal and from the Powerplant Control Panel and sends a command signal to the FPMU, which meters the fuel flow to the engine in order to reach the fan spool speed calculated by the FADEC thrust management section.

Both FADECs alternate powerplant control. While one FADEC controls the powerplant, the other remains in standby mode. The standby FADEC monitors all inputs, performs all computations, and performs built-in-test and fault detection. However, the output drivers (fuel flow and CVG control), that command the engine, are powered off.

The active FADEC is alternated at each engine ground start in order to minimize the probability of latent failure within the powerplant control system/airplane interface.

The selection logic resides within the FADECs that memorize which FADEC was used for the last engine start and commands the other one to perform the next start, regardless of which FADEC is used in flight.

For example: If FADEC B was used for the last start, when the pilot actuates the next start, the selection logic will select FADEC A, as shown in the following table:

Start	In flight (alternated)	Following start
FADEC A	FADEC B or A	FADEC B
FADEC B	FADEC A or B	FADEC A

Transfer from active FADEC to standby FADEC may also be accomplished automatically, in response to a detected fault, or manually, through the FADEC Selector Knob, located on the overhead panel. The manual selection overrides the automatic selection of the controlling FADEC unless the manually selected FADEC is not capable of safely controlling the engine.

If a fault condition is detected in the engine sensor, actuator interface, or airplane interface of the controlling FADEC, it will maintain control by using data borrowed from the standby FADEC. If required data is not available, the controlling FADEC will use default data or switch to reversionary control mode.

Control will be transferred to the standby FADEC only when the controlling FADEC detects a fault that will result in degraded engine operation or will render it unable to control the engine.

All measured powerplant control parameters, control system faults and status information are presented on the EICAS.

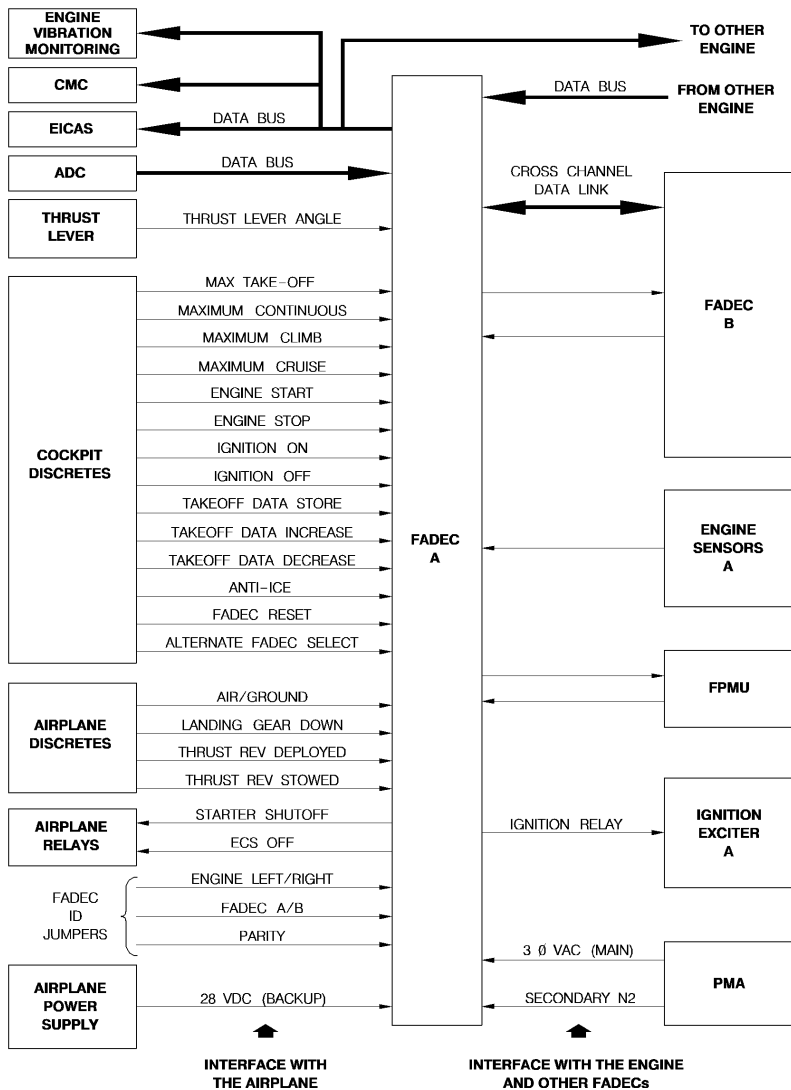

145114207.MCE

AOM-145/1114

FADEC SCHEMATIC

JUNE 28, 2002

2-10-40	Page 3	Code 01
---------	-----------	------------

N1TARGET CALCULATION

The FADEC calculates the maximum available engine thrust for a given thrust rating mode, airspeed and ambient conditions, and bleed air configuration. Maximum thrust corresponds to N1TARGET displayed on the EICAS as a cyan bug on the N1 analogic indicator arc.

When the Thrust Lever is set to the THRUST SET position, the FADEC controls the engine at N1TARGET.

In normal mode (with no ADC faults) the following data are used as primary reference for the N1TARGET calculation:

- Pressure Altitude and Mach Number reference from ADCs.
- Temperature references (REF TO TEMP during takeoff and ADC TAT in flight).
- A-ICE condition (REF A-ICE during takeoff and actual A-ICE system feedback in flight).
- Takeoff mode.

N1REQUEST CALCULATION

The N1REQUEST is a function of N1TARGET and Thrust Lever Angle. The FADEC controls the engine to N1REQUEST at steady state, except if the thrust lever is at Ground Idle position. In this case, the engine is controlled according to the Ground Idle N2 schedule.

The table below presents the main Thrust Lever positions, corresponding Thrust Lever Angle bands, and N1REQUEST for ground operation.

POSITION	TLA	N1REQUEST
MAX REVERSE	0 to 4°	N1REV
MIN REVERSE	14° to 22°	N1IDLE
IDLE	22° to 28°	N1IDLE
THRUST SET	72° to 78°	N1TARGET
MAX THRUST	Above 78°	N1TARGET

N1REV is the N1 value for MAX REVERSE thrust.

Each thrust lever modulates engine thrust linearly between IDLE and THRUST SET position. There is no thrust modulation between IDLE and MIN REVERSE.

N1REQUEST is shown as a green bug on the N1 analogic indication arc on the EICAS.

GROUND/FLIGHT IDLE THRUST SCHEDULE

There is only one IDLE position on the thrust lever control pedestal. However, there are two different IDLE ratings (ground and flight Idle), set as a function of the Air/Ground input to the FADEC:

– GROUND IDLE SPEED

During ground operations, the FADEC commands the engine to Ground Idle Speed, which is scheduled in order to:

- Avoid engine flameout, overtemperature or inability to accelerate.
- Provide the required air bleed flow pressure and temperature for the ECS.
- Provide the required gas generator speed to drive the accessories.

Ground Idle Speed is scheduled as a function of ambient temperature.

– FLIGHT IDLE THRUST

In flight operation, the FADEC will command the engine to Flight Idle Thrust, which is scheduled in order to:

- Avoid engine flameout, overtemperature or inability to accelerate.
- Provide the required bleed airflow pressure and temperature for the ECS and for the Anti-Icing System. If the FADECs receive an indication that the anti-icing system is on, Flight Idle thrust is rescheduled in order to provide the required air bleed flow, pressure and temperature. This automatic A-ICE Flight Idle rescheduling is inhibited below 15000 ft if the landing gear is down and locked.
- Enable the FADEC to accelerate the engine from Flight Idle Thrust to 100% of the Go-around thrust mode in 8 seconds or less, at or below 9500 ft.

CLOSED-LOOP FAN SPEED CONTROL

The primary control mode of the engine is closed-loop fan speed control. The fan speed requested by thrust lever is compared to the measured fan speed. An error signal proportional to the difference between the request and measured fan speed is used to adjust the commanded fuel flow to the engine to drive the fan speed error to zero.



N1/N2 OVERSPEED/UNDERSPEED PROTECTION

The FADEC limits fuel flow to prevent the excessive rotor speed on both the low-pressure rotor (N1) and the high-pressure rotor (N2). If the fuel flow commanded by the closed-loop results in the surpassing of established rotor speed limits, fuel flow will be limited to that value which will result in rotor speed limit.

The FADEC also incorporates a logic to initiate an engine shutdown if the upper limits of N1 and N2 are exceeded, in order to avoid a potentially destructive overspeed condition.

Logic within the FADEC incorporates a high-pressure rotor (N2) underspeed shutdown. This logic prevents damaging the turbine via an overtemperature condition if the engine attempts to operate at sub-idle speed. If N2 drops below 54% the FADEC will command a shutdown.

The maximum steady-state rotor speeds are 100% N1 and 102.5% N2 (103.7% N2 for A1E engines). There is no minimum N1 speed.

INTERSTAGE-TURBINE TEMPERATURE (ITT) LIMITING

The FADEC has provisions for limiting engine fuel flow to prevent exceeding ITT limits. If the fuel flow commanded by the closed-loop fan speed control exceeds established ITT limits, the FADEC will limit the fuel flow to that value that will result in operation within the ITT limit.

ACCELERATION/DECELERATION LIMITING

Acceleration and deceleration limits within the FADEC logic restrict the rate of commanded engine fuel flow to prevent surge during acceleration or lean blow out during deceleration.

FLAMEOUT DETECTION/AUTORELIGHT

Flameout and autorelight detection logic within the FADEC detects an engine flameout and attempts an automatic relight before the engine loses power, if N2 is higher than 53%. In the event that a relight cannot be successfully executed, the FADEC commands an engine shutdown.

During in-flight restarts, both ignition systems are energized.

N1 REVERSIONARY CONTROL MODE

The FADEC provides a reversionary control mode to accommodate a total loss of fan-speed (N1) signal.

The FADEC stores data on the correlation between N1 and N2 of an average engine in its non-volatile memory, and in the event that all N1 signals are lost, it will control thrust governing N2 speed.

The engine control system is capable of modulating thrust in response to thrust lever movement in the reversionary control mode. However, transient response times may be greater, minimum thrust may exceed flight idle thrust and maximum thrust may be less than that expected during normal control operation.

This mode is evident to the pilot due to the absence of N1 indication on the EICAS.

FADEC INPUTS SELECTION AND FAULT ACCOMMODATION

For every FADEC input, there is a selection and fault accommodation logic, based on the inputs to both FADECs of the same engine.

The engine control system is highly fault tolerant. Because of redundant sensor inputs and outputs, the control system can accommodate multiple faults with no degradation in engine response. The fault accommodation philosophy is to maintain operation on the controlling FADEC for as long as possible before transferring control to the standby FADEC.

For every detectable fault, the FADEC provides a signal to the EICAS for the alerting message or to the Central Maintenance Computer for the maintenance message.

FADEC DISCRETE OUTPUTS

Each FADEC provides two discrete output signals, as follows:

- N2 Speed Switch - Each FADEC activates a discrete output whenever the engine is assumed to be running, based on N2. This signal is activated whenever N2 reaches (accelerating) 56.4% and is deactivated whenever N2 drops below 53%.
- ECS OFF signal.

ALTERNATE FADEC SELECTION

AUTOMATIC SELECTION

- Whenever the FADEC in control is unable to safely control the engine, it signals the alternate FADEC to automatically take over engine control.

MANUAL SELECTION

- The alternate FADEC may be manually selected to control the engine, by momentarily setting the FADEC Control Knob, located on the overhead panel, in the ALTN position.

The FADEC that is in control (A or B) is indicated on the EICAS.

FADEC RESET

The FADEC may be reset through the FADEC Control Knob. Upon receiving the FADEC Control Knob input, the FADEC clears recorded inactive faults (faults not currently being detected).

In case any fault persists after the RESET command, it is not cleared.

Reset does not mean electrical power interruption to the FADEC.

ENGINE OPERATION

GENERAL

The Rolls-Royce AE 3007 engine uses an electronic control system based on two Full Authority Digital Electronic Controls (FADECs) that control the engine. These FADECs interface with the engine, airframe and flight deck. A complete description of the engine control system was presented in the previous chapter.

THRUST RATINGS

The engine control system schedules the corrected fan speed as a function of pressure altitude, Mach number, ambient temperature, anti-ice system condition, thrust mode and thrust lever angle to achieve the rated thrust conditions.

Thrust ratings for AE 3007 engines are:

Engines	A, A1,A1/1, and A3		A1P and A1/3		A1E	
	Selectable	ATTCS	Selectable	ATTCS	Selectable	ATTCS
E Takeoff Reserve	-	-	-	-	-	E T/O RSV*
E Takeoff	-	-	-	-	E T/O*	E T/O RSV*
Takeoff Reserve	-	-	-	T/O RSV*	-	T/O RSV*
Takeoff	-	-	T/O*	T/O RSV*	T/O*	T/O RSV*
Maximum Takeoff-1	T/O-1*	T/O-1*	-	-	-	-
Alternate Takeoff-1	ALT T/O-1*	T/O-1*	ALT T/O-1*	T/O-1*	ALT T/O-1*	T/O-1*
Maximum Continuous	CON	-	CON	-	CON	-
E Maximum Climb	-	-	-	-	E CLB	-
Maximum Climb	CLB	-	CLB	-	CLB	-
Maximum Cruise	CRZ	-	CRZ	-	CRZ	-

*Restricted to 5 minutes

For A1E engines, E T/O RSV and T/O RSV modes are not intended for normal operation. Their use must be recorded in the maintenance logbook.

For the respective takeoff rating, altitude, and Mach-number condition, fan speed is controlled to maintain constant thrust at any given ambient temperature below the flat-rated ambient temperature.



ENGINE CONTROL

The engine control system controls the operation of the engine throughout its operating envelope. The system modulates the fuel flow rate to the engine and the position of the variable geometry vanes (CVG) in response to inputs from the aircraft's sensors and measurements of engine operating conditions. The engine control system will not command a fuel flow that would result in exceeding rotor speed or temperature operating limits.

The engine control system is designed in such a manner that a single electrical failure will not cause significant thrust changes, result in an uncommanded engine shutdown or prevent a commanded engine shutdown. In case of loss of both FADECs, the engine control system will shut off fuel flow and move the CVGs to the closed position.

The engine control system performs two categories of functions: thrust management and engine control. Thrust management logic interfaces with the airframe and schedules a corrected thrust based on air data and cockpit inputs. The fan speed request is passed to the engine control logic, which controls the engine fuel flow and Compressor Variable Geometry (CVG) in response to the measured parameters in order to attain the required engine response.

THRUST MANAGEMENT

This section of the FADEC software is responsible for functions directly involved in the required thrust computation and management logic. Thrust management logic is provided to reduce flight crew workload and enhance the aircraft's operation.

Thrust management functions are as follows: thrust mode selection, fan speed (N1) scheduling, Automatic Takeoff Thrust Control (ATTCS), Takeoff Data Setting (TDS), and thrust reverser interlock.

THRUST MODE SELECTION

Thrust logic management includes several thrust-rating modes that are controlled through associated buttons on the cockpit, set during the takeoff data setting procedure, automatically triggered by the ATTCS or by advancing the Thrust Lever Angle (TLA) above the thrust set position.

Thrust-rating mode defines the available engine thrust at the existing ambient conditions. The following thrust modes are available:

2-10-50	Page 2	Code 01
---------	-----------	------------

ALTERNATE TAKEOFF (ALT T/O-1)

- All engines:

This mode is the normal all engines operating takeoff mode and is available only through the use of the Takeoff Data Setting procedure.

Selection of this mode ensures the best engine durability and economy of operation. In this mode the ATTCS is active, so that T/O-1 mode is triggered in case of engine failure.

MAXIMUM TAKEOFF-1 (T/O-1)

- A, A1, A1/1 and A3 engines:

This mode is the maximum, all engines operating takeoff mode. For engine durability and economy of operation, this mode should only be selected when ALT T/O-1 is not authorized. The engine will produce the maximum rated thrust for the existing ambient conditions in T/O-1 mode. This mode is automatically selected when ATTCS is triggered during operation in ALT T/O-1 mode. T/O-1 is automatically selected at FADEC power up and at the initiation of the Takeoff Data Setting procedure. T/O-1 is also automatically selected in flight below or descending through 15000 ft provided the landing gear is down and locked. T/O-1 is selected if there is weight on wheels, the TLA is at 50° or less and the T/O thrust-rating button is pushed. This mode is also selected if both engines do not agree on the thrust mode or when the thrust mode of the remote engine cannot be determined. Besides, this mode is selected when the T/O thrust-rating button is pushed and the pressure altitude is greater than 1700 ft above takeoff. The T/O-1 mode is automatically selected whenever the TLA is advanced above the THRUST SET position regardless of the mode previously selected. ATTCS is not active in this mode.
- A1P and A1/3 engines:

This is the One Engine Inoperative (OEI) mode for the normal, all engines operating, ALT T/O-1 mode. In addition to being selected by an ATTCS trigger, it may also be selected from ALT T/O-1 mode, at or below 1700 ft above takeoff pressure altitude, by pushing the T/O thrust-rating button. It is not a normal pilot selectable takeoff mode.
- A1E engine:

This is the One Engine Inoperative (OEI) mode for the normal, all engines operating, ALT T/O-1 mode. The FADECs will select T/O-1 mode if the T/O switch is pressed and the current mode is ALT T/O-1 during takeoff phase, if the ATTCS is triggered and



the current mode is ALT T/O-1 or if the thrust lever is moved beyond THRUST SET position and the current mode is ALT T/O-1.

TAKEOFF (T/O)

- A1P and A1/3 engines:
This mode is the maximum, all engines operating takeoff mode. For engine durability and economy of operation, this mode should only be selected when ALT T/O-1 is not authorized. ATTCS is active in this mode, so that ATTCS triggers upon detection of an engine failure, commanding a thrust increase to T/O RSV mode. The T/O mode is automatically selected at FADEC power up, and at the initialization of the Takeoff Data Setting procedure. T/O is also automatically selected in flight below or descending through 15000 ft provided the landing gear is down and locked. T/O is selected if there is weight on wheels, the TLA is at 50° or less and the T/O thrust-rating button is pushed. This mode is also selected when the T/O thrust-rating button is pushed and the pressure altitude is greater than 1700 ft above takeoff altitude.
- A1E engine:
This is a medium thrust level, selectable through the Takeoff Data Setting procedure, for all engines operating. For engine durability and economy this mode should be selected if conditions do not permit use of ALT T/O-1 but do not require E T/O mode.

EXTENDED TAKEOFF (E T/O)

- A1E engine:
This mode is the highest level, all engines operating, takeoff mode. For engine durability and economy of operation, this mode should only be selected when T/O mode is not authorized. In case of engine failure the ATTCS triggers the E T/O RSV mode. The E T/O is automatically selected at FADEC power-up and also at initiation of the Takeoff Data Setting procedure. E T/O is also automatically selected in flight, at or below 15000 ft, when the landing gear down and locked is received by the FADECs on both engines. This mode is also selected when the T/O button is pushed and the pressure altitude is greater than 1700 ft above takeoff altitude. The FADECs will select E T/O mode if the T/O switch is pressed after takeoff phase, if the T/O switch is pressed and the current mode is T/O-1 or if the thrust lever is moved beyond THRUST SET position in flight or after takeoff phase.

2-10-50	Page 4	Code 01
---------	-----------	------------

TAKEOFF RESERVE (T/O RSV)

- A1P and A1/3 engines:

This mode is the corresponding OEI mode for all engines operating in T/O mode. The engine will produce the maximum rated thrust for the existing ambient conditions in this mode. T/O RSV is automatically selected when ATTCS is triggered during operation in T/O mode. T/O RSV is also selected if both engines do not agree on the thrust mode or when the thrust mode of the remote engine cannot be determined. This mode will also be selected from the T/O mode, at or below 1700 ft above takeoff altitude, when the T/O thrust-rating button is pushed.

NOTE: T/O RSV is manually selected by advancing one or both TLA above Thrust Set position, regardless of any mode previously selected.

- A1E engine:

This is the corresponding OEI mode for all engines operating in T/O mode. This mode is accessible through a FADEC command in response to an ATTCS triggering event. The FADECs will select T/O RSV mode if the T/O switch is pressed and the current mode is T/O during takeoff phase, if the ATTCS is triggered and the current mode is T/O or if the thrust lever is moved beyond Thrust Set position and the current mode is T/O. This mode is also accessible by pressing the takeoff button while in T/O and the aircraft is in post takeoff condition or on the ground.

NOTE: The use of this mode requires a notation in the aircraft maintenance log.

EXTENDED TAKEOFF RESERVE (E T/O RSV):

- A1E engine:

This mode is the corresponding OEI mode for all engines operating in E T/O mode. E T/O RSV is automatically selected when ATTCS is triggered during operation in the E T/O mode. The FADECs will select E T/O RSV mode if the T/O switch is pressed and the current mode is E T/O or T/O RSV during takeoff phase, if the ATTCS is triggered and the current mode is E T/O, if the thrust lever is moved beyond Thrust Set position and the current mode is E T/O or if the thrust lever is moved beyond the Thrust Set position and the takeoff button is pressed.

NOTE: Use of this mode requires a notation in the aircraft maintenance log.

MAXIMUM CONTINUOUS (CON)

- All engines:
This mode is selected by pushing the CON push button. CON mode is available when the pressure altitude is greater than 300 ft above takeoff altitude and there is no landing gear down and locked, or when the pressure altitude is greater than 1700 ft above takeoff altitude. The CON mode switch inputs to the FADECs are inhibited on ground.

MAXIMUM CLIMB (CLB)

- All engines:
This mode is selected by pushing the CLB push button. CLB mode is enabled when the pressure altitude is greater than 500 ft above takeoff altitude, there is no landing gear down and locked signal and there is no OEI signal, or when pressure altitude is greater than 1700 ft above takeoff altitude and there is no OEI signal. The CLB mode switch inputs to the FADECs are inhibited on ground. For A1E engines CLB is the default mode when T/O or ALT T/O-1 is selected for takeoff.

EXTENDED CLIMB (E CLB)

- A1E engine:
This mode is enabled under the same CLB conditions described above. However, E CLB is the default mode when E T/O is selected. Pressing the CLB button while in CLB mode toggles the climb thrust to E CLB and vice-versa.

MAXIMUM CRUISE (CRZ)

- All engines:
This mode is selected by pushing the CRZ push button. CRZ mode is enabled when the pressure altitude is greater than 500 ft above takeoff altitude, there is no landing gear down and locked signal, and there is no OEI signal, or when pressure altitude is greater than 1700 ft above takeoff altitude and there is no OEI signal.

AE3007A1E THRUST MODE SELECTION

Thrust mode selection on A1E engines is a bit more complex than on the other engines. The following tables illustrate how the thrust modes can be selected by pressing the T/O button, by advancing Thrust Levers above thrust Set or by the ATTCS.

PRESSING TAKEOFF BUTTON

Current Mode	During takeoff phase (1)	Post takeoff phase
ALT T/O-1	T/O-1	E T/O
T/O-1	E T/O	E T/O
T/O	T/O RSV	E T/O
T/O RSV	E T/O RSV	E T/O (2)
E T/O	E T/O RSV	E T/O

- (1) Takeoff phase is configured when altitude is less than 1700 ft above takeoff altitude, five minutes or less time has been elapsed since thrust set selection for takeoff and current thrust mode is one of the takeoff modes.
- (2) T/O RSV to E T/O is a thrust decrease.
- (3) If current thrust is E T/O RSV, flight altitude is between 1700 ft above takeoff altitude and 15000 ft and the takeoff button is pressed, thrust will decrease to E T/O.

ADVANCING THRUST LEVERS ABOVE THRUST SET POSITION

Thrust Lever Angle above Thrust Set (TLA>78°) ATTCS <u>NOT</u> triggered		
Current Mode	During takeoff phase	Post takeoff phase
ALT T/O-1	T/O-1	E T/O
T/O	T/O RSV	E T/O
E T/O	E T/O RSV	E T/O
CON, CLB, E CLB CRZ	-	E T/O
T/O-1 (1)	T/O-1	E T/O
T/O RSV (1)	T/O RSV	E T/O RSV
E T/O RSV (1)	E T/O RSV	E T/O RSV

- (1) If the ATTCS is not triggered, these three modes are only accessible by pressing the T/O button after selecting normal engine takeoff modes through the Takeoff Data Setting procedure.

Thrust Lever Angle above Thrust Set (TLA>78°) ATTCS triggered			TLA>78° and T/O button pressed
Current Mode	After ATTCS trigger	TLA > 78°	
ALT T/O-1	T/O-1	T/O-1	E T/O RSV
T/O	T/O RSV	T/O RSV	E T/O RSV
E T/O	E T/O RSV	E T/O RSV	E T/O RSV

Pushing the Takeoff Button with the Thrust Lever above Thrust Set will select E T/O RSV mode regardless of the current takeoff mode or flight phase.

FAN-SPEED SCHEDULING

The thrust management logic calculates the corrected fan-speed request at any point in the flight envelope. The scheduled, corrected fan speed is computed as a function of pressure altitude, Mach number, air temperature and other aircraft signals.

The thrust lever quadrant has five significant thrust positions defined as:

Thrust Lever Position	Thrust Level Angle
Maximum Reverse	0-4°
Minimum reverse	14-22°
Idle	22-28°
Thrust Set	72-78°
Maximum Thrust	78-85°

Maximum reverse and maximum thrust are defined by mechanical stops at either extremes of the thrust lever movement. Idle is defined by a mechanical gate that must be lifted to allow the thrust lever to transition from forward flight to the reverse flight region. The thrust set position on the thrust lever is delineated by a detent at 75°. For any given pressure altitude, Mach number and air temperature the FADEC computes a corrected fan speed corresponding to the thrust lever position. The fan speed computed for the thrust lever position is dependent upon the selectable thrust mode. The Target Thrust (N1 Target) is defined as the thrust corresponding to the corrected fan speed scheduled with the thrust lever at the Thrust Set position. A target thrust is computed for each thrust mode. Flight idle thrust corresponds to the corrected fan speed with the TL at the idle position and is independent of the thrust mode. The FADEC schedules the corrected fan speed as a function of the thrust lever angle and the thrust mode to result in the following linear relationships:

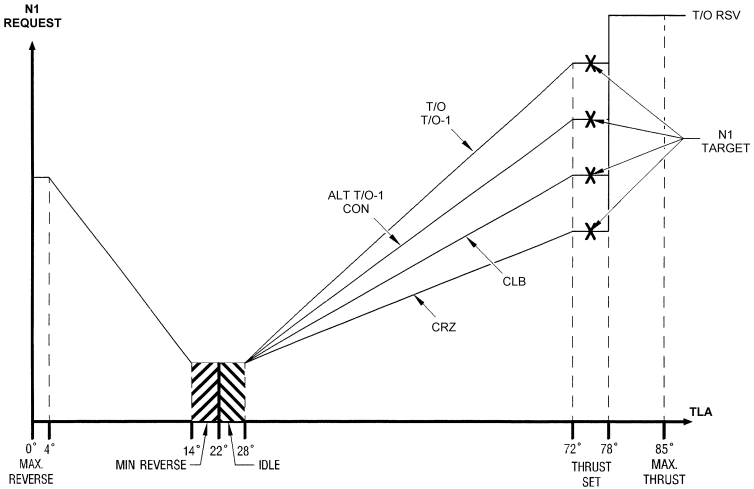

A1P and A1/3 Engines

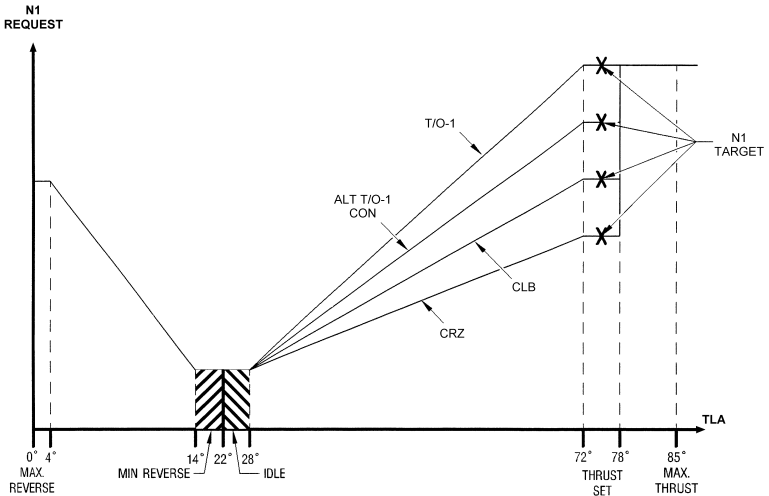

A, A1, A1/1 and A3 Engines

Any movement of the thrust levers above the Thrust Set position results in the scheduling of the maximum takeoff thrust, regardless of the current thrust mode, except for A1E engines (refer to A1E Thrust Mode Selection). A thrust lever position below the idle gate schedules reverse thrust provided such action is enabled by the thrust reverser interlock logic.

AOM-145/1114

ALTERNATE TAKEOFF THRUST CONTROL SYSTEM

During a takeoff, if an engine failure is detected, the ATTCS automatically resets thrust on the remaining engine from Alternate Takeoff thrust to Maximum Takeoff thrust. In addition, depending on takeoff thrust setting and ambient conditions, the FADECs generate an ECS OFF signal to close the Pack Valves. (Refer to ECU operation on Section 2-14).

ATTCS ARMING CONDITIONS

ATTCS is armed when:

- Both engines are ATTCS capable,
- Associated thrust lever angle is equal to or higher than 45°.

NOTE: ATTCS capable is defined as E T/O (A1E engine), T/O (A1P, A1/3 or A1E engines) or ALT T/O-1 (all engines) mode selected, with the airplane on ground and the engine running.

ATTCS TRIGGERING CONDITIONS

After being armed, the ATTCS is triggered under any of the following conditions:

- The thrust lever for the opposite engine is reduced to below 38° TLA.
- Either FADEC for the on-side engine receives an opposite engine or on-side engine inoperative condition, or a Thrust Lever Angle limited to idle signal.
- The opposite engine does not indicate ATTCS being armed, within 2 seconds after the on-side engine ATTCS has armed.
- The opposite engine disarms ATTCS and the on-side engine does not disarm within 2 seconds.

If ATTCS is armed and either FADEC A or B detects an opposite engine inoperative condition, the controlling FADEC commands the on-side engine to a higher takeoff thrust, as shown in the table:

Engines	Takeoff Selection Two Engines Operation	ATTCS Triggered One Engine Operation
A, A1, A1/1, A3	ALT T/O-1	T/O-1
A1P, A1/3	ALT T/O-1	T/O-1
	T/O	T/O RSV
A1E	ALT T/O-1	T/O-1
	T/O	T/O RSV
	E T/O	E T/O RSV

ATTCS DISARMING CONDITIONS

The ATTCS disarms if any of the following conditions is met:

- After being armed, the Thrust Lever Angle is reduced below 42°.
- ATTCS is triggered on either engine.
- No ATTCS capable takeoff mode is selected.

NOTE: If thrust lever is moved beyond the THRUST SET position the FADEC automatically commands the engine to the maximum available thrust (T/O-1 mode for A, A1/1, A1 and A3 engines, or T/O RSV mode for A1/3 and A1P engines), disregarding the takeoff mode selected, except for A1E engine (see A1E engine Thrust Mode Selection section).

TAKEOFF DATA SETTING

The Takeoff Data Setting function is provided in order to enable the pilot to input reference data into the FADEC prior to takeoff. Such data will be used to calculate N1TARGET during takeoff. The following data has to be input:

- Takeoff Mode (T/O MODE), which corresponds to:
 - T/O-1 or ALT T/O-1 (A, A1/1, A1 or A3 engines).
 - T/O or ALT T/O-1 (A1P or A1/3 engines).
 - E T/O, T/O or ALT T/O-1 (A1E engine).
- Reference Takeoff Temperature (REF TO TEMP), which shall correspond to the Static Air Temperature (SAT) on the ground provided by the Air Traffic Control Tower, ATIS (Automatic Terminal Information Service) or other accurate source.



- Reference Takeoff Anti-Ice Condition (REF A-ICE), which is the anti-ice system condition (ON/OFF) that the FADEC will consider to calculate N1TARGET.

This function is enabled during ground operations only and with thrust lever angle below 50°, before or after engine start.

The takeoff data setting is performed through the Takeoff Data Setting controls (STORE button and SET control) on the overhead panel.

After selecting the takeoff page on the MFD, The Takeoff Data Setting procedure shall be as follows:

- a) After the first pressing of the STORE button, the MFD indicates the following initial values for the three takeoff data:
 - T/O MODE: T/O-1 for A, A1, A1/1 and A3 engines;
T/O for A1P or A1/3 engines;
E T/O for A1E engine.
 - REF TO TEMP: T2SYN (if engine is running) or
ISA Temperature (otherwise).

NOTE: - T2SYN is the synthesized total air temperature at the engine fan inlet.

- T2.5 is the fan discharge total air temperature.

- REF A-ICE: OFF.

An arrow points to T/O MODE line. Through the SET Control the takeoff mode ALT T/O-1 may be selected.

- b) At the second pressing of the STORE button, the arrow points to REF TO TEMP, indicating that this parameter may be adjusted. Through the SET control, the initial value may be adjusted to the required temperature. Each momentary command of the SET control will increase (INC) or decrease (DEC) the current value by 1°C. If the SET control is held at the command position for more than 1 second, the REF TO TEMP is changed by 5°C/sec.

NOTE: The acceptable REF TO TEMP value range is limited to T2SYN ± 10°C.

- c) At the third pressing of the STORE button, the arrow points to REF A-ICE line, indicating that this parameter may be adjusted. Through the SET control, the initial condition (OFF) can be switched to ON and back to OFF alternately.

2-10-50	Page 12	Code 01
---------	------------	------------

- d) At the fourth pressing of the STORE button:
- If the engines are running and the REF TO TEMP is within limits ($T2SYN \pm 10^{\circ}\text{C}$):
 - The FADECs accept the takeoff data and successfully terminate the procedure.
 - The MFD displays the takeoff data.
 - The FADEC begins to calculate and display the N1TARGET based on the takeoff data.
 - If the engines are not running, the adjusted takeoff data will remain displayed in amber color, which means that they have not been accepted yet. Then:
 - After engines start, if the adjusted REF TO TEMP is within limits, the FADECs accept the takeoff data and successfully terminate the procedure, the MFD displays the takeoff data, and the FADEC begins to calculate and display the N1TARGET based on the takeoff data.
 - Otherwise, the takeoff data will not be accepted by the FADECs and the MFD will display dashed lines for all takeoff data in amber color, and a caution message (ENG NO TO DATA) is presented on the EICAS if $TLA > 45^{\circ}$.
 - In order to enter the correct takeoff data, the procedure must be started again, through the STORE button.
- e) If, after takeoff data had been successfully entered, the pilot needs to correct any of them, the STORE button must be commanded again in order to restart the procedure.
- f) In case of disagreement between the REF A-ICE condition selected by the pilot and the actual Anti-Ice system condition, a caution message (ENG REF A/I DISAG) is displayed on the EICAS, provided the Parking Brake is released (OFF) or with any Thrust Lever Angle above 45° .
- g) If any thrust lever is set to an angle above 45° before takeoff data successfully entered, a caution message (ENG NO TO DATA) is presented on the EICAS.

ENGINE START

Engine start, commanded through the Start/Stop Knob, is automatically managed by the FADEC as follows:

- The FADECs A and B alternate as FADEC in control on every subsequent ground start. If the Ignition Selector Knob is set to AUTO position, a single ignition system, corresponding to the FADEC in control, will be used.
- The FADEC activates the ignition system when N2 is at approximately 14% and commands the fuel solenoid valve to open when N2 is at approximately 31.5% (28.5% for airplanes equipped with FADEC B7.4 and on) or 12 seconds after ignition is activated, if the Ignition Selector Knob is set to AUTO or ON position.
- Whenever the start cycle is completed, the FADEC deactivates the ignition system and provides a discrete signal to command the Starting Control Valve (SCV) to close.
- If the Ignition Selector Knob is set to OFF position, the FADEC neither activates the ignition system nor actuates the fuel valve from closed to open position, in order to enable ground/flight dry motoring.

NOTE: If the engine is already running with TLA above IDLE thrust, the fuel valve is not closed, even if the Ignition Selector Knob is set to OFF position.

- The FADEC monitors Interturbine Temperature (ITT) start limit override during ground starts. If the temperature exceeds the control temperature reference, the FADEC reduces fuel flow. Only FADEC B7.4 and on automatically command an engine shutdown for an overtemperature on start. When the engine is started on ground, only the FADEC in control commands ignition, if the Ignition Selector Knob is set to AUTO position. During an in flight start, both FADECs command ignition.
- If a flameout is detected, the FADEC turns on the ignition system, provided the ignition switch is in the AUTO position, until the engine is restarted.

ENGINE DRY MOTORING

An Engine Dry Motoring must be performed for at least 30 seconds after any aborted start to assure that no unburned fuel remains in the combustion chamber and/or to reduce residual ITT prior to attempting another start.

Ignition switch must be rotated to Off position in order to disable ignition and fuel flow prior to rotating the Stop/Run/Start switch to the start position.

ENGINE SHUTDOWN

Normal engine shutdown, through the Start/Stop Knob, is managed by the FADEC, which commands the engine fuel solenoid valve to close. The normal sequence only occurs with the thrust levers positioned at Idle. Thrust levers should be positioned at IDLE before the Start/Stop Knob is positioned at Stop.

A shutdown sequence is also performed whenever N2 is below 54%.

NOTE: The Engine Fire Extinguishing Handle, when actuated, also shuts the engine down by closing the respective fuel shutoff valve, interrupting fuel supply from the wing tanks.

EICAS MESSAGES

TYPE	MESSAGE	MEANING
WARNING	ENG 1-2 OUT	N2 has dropped below 8500 rpm on both engines (underspeed shutdown limit) uncommanded.
	ATTCS FAIL (if applicable)	ATTCS failure associated with a low N1.
	E1 (2) ATTCS NO MRGN	The engine has no ITT or N2 margin to achieve higher thrust if ATTCS is trigged.
	E1 (2) OIL LOW PRESS	Oil pressure has dropped below 34 psi and the engine is running or the pressure switch has failed at the closed position and the engine is not running.
	E1 (2) LOW N1	Engine does not achieve requested N1.
CAUTION	E1 (2) FUEL LO TEMP	The fuel temperature in the engine has dropped below 5°C.
	E1 (2) ATS SOV OPN	The engine ATS shutoff valve (SCV) remained open above 53% N2.
	ENG REF A/I DISAG	Disagreement between the REF A-ICE condition selected by the pilot and the actual anti-icing system condition has been detected by the engine control associated with Parking Brake released (OFF) or with any TLA above 45°.
	E1 (2) CTL A (B) FAIL	A failure in the Engine control system has been detected.
	E1 (2) CTL FAIL (if applicable)	A failure in the Engine control system has been detected.
	ENG1 (2) TLA FAIL	Thrust Lever Angle sensor has failed.

(Continued)

TYPE	MESSAGE	MEANING
CAUTION	ENG NO TO DATA	Takeoff Data has not been successfully entered with engine running and above 53% N2.
	FADEC ID NO DISP (if applicable)	There are different FADEC applications installed in the aircraft.
	ENG 1 (2) OUT (if applicable)	N2 has dropped below 8500 rpm (underspeed shutdown limit) uncommanded.
	E1(2) NO DISP (if applicable)	Associated FADEC has detected a non-dispatch failure condition.
	E1 (2) EXCEEDANCE (if applicable)	ITT or N2 exceeded the current ITT or N2 limit during an interval of the flight leg.
	E1 (2) FPMU NO DISP (if applicable)	An incompatible FPMU was installed on a A1E engine.
ADVISORY	E1 (2) OIL IMP BYP	The differential pressure across the oil filter has exceeded the normal range.
	E1 (2) FUEL IMP BYP	The differential pressure across the fuel filter has exceeded the normal range.
	E1 (2) ADC DATA FAIL	Loss of either ADC data or synthesized T2 used as temperature source.
	E1 (2) FADEC FAULT (if applicable)	A dispatchable MMEL category B FADEC fault was detected.
	E1 (2) CTL A (B) DEGRAD (if applicable)	A dispatchable MMEL category B FADEC fault was detected.
	E1 (2) SHORT DISP (if applicable)	A dispatchable MMEL category B FADEC fault was detected.
	CHECK XXX PERF (XXX=A, A1, A1/1, A1P, A3, A1/3, A1E) (if applicable)	Inform the FADEC application installed in the aircraft. Displayed only on ground with flaps 0° and parking brakes applied.

**AIRPLANE
OPERATIONS
MANUAL**



THIS PAGE IS LEFT BLANK INTENTIONALLY

2-10-50	Page 18	Code 01
---------	------------	------------

DECEMBER 20, 2002

ACM-145/1114



CONTROLS AND INDICATORS

CONTROL PEDESTAL

1 - GUST LOCK LEVER

Limits thrust lever movement and locks the elevator control surfaces when set in LOCKED position.

Refer to Section 2-13 – Flight Controls.

2 - THRUST LEVER

MAX - Provides maximum takeoff thrust.

THRUST SET - Provides N1TARGET thrust setting.

IDLE - Provides ground and flight idle thrust settings.

MAX REV - Provides maximum reverse thrust.

NOTE: Protection against inadvertent thrust reverser command in flight is provided through the mechanical idle stop and the electrical flight idle stop.

3 - FRICTION LOCK

Rotated clockwise, thrust lever movement becomes progressively more resistant, so that thrust levers will not slip.

4 - THRUST RATING MODE buttons

T/O - Selects maximum takeoff thrust-rating mode.

CON - Selects maximum continuous thrust-rating mode.

CLB - Selects maximum climb thrust-rating mode.

CRZ - Selects maximum cruise thrust-rating mode.

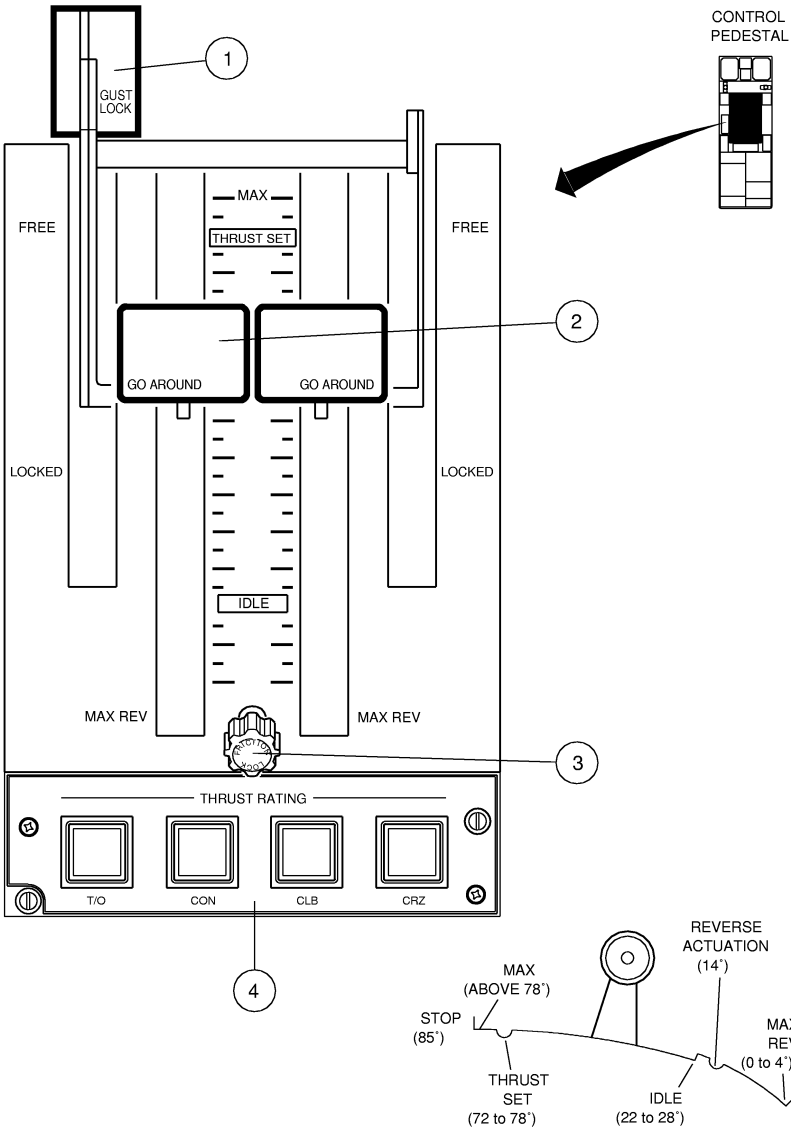

145AOM2100008.MCE

CONTROL PEDESTAL

POWERPLANT CONTROL PANEL

1 - IGNITION SELECTOR KNOB

OFF - Deenergizes the ignition system.

AUTO - FADECs control the ignition system automatically, depending on the engine requirement.

ON - Commands the FADEC to activate continuously the two ignition channels.

2 - FADEC CONTROL KNOB (SPRING-LOADED TO NEUTRAL)

RESET - Resets the FADECs, and clears faults.

ALTN - Alternates the FADEC in control.

NOTE: The knob becomes inoperative if held in any position for more than 3 seconds.

3 - TAKEOFF DATA STORE BUTTON

- Initiates and terminates takeoff data setting.
- At the first pressing, an arrow points to T/O MODE line.
- At the second pressing allows REF TO TEMP adjustment.
- At the third pressing allows REF A-ICE to be input.
- At the fourth pressing, if REF TO TEMP is within limits, the takeoff data is accepted and the procedure is successfully accomplished.
- For complete procedures refer to Takeoff Data Setting paragraph.

NOTE: The button becomes inoperative if held pressed for more than 3 seconds.

4 - TAKEOFF DATA SET CONTROL

- When turned, selects the T/O MODE, increases (INC) or decreases (DEC) the REF TO TEMP value and also switches the A-ICE condition state presented on the MFD during takeoff data setting.
- Momentary actuation changes the REF TO TEMP values by 1°C. If the control is held for more than 1 second at the INC or DEC position, REF TO TEMP is changed by 5°C/sec.
- The mode T/O-1 can be switched to ALT T/O-1 and back to T/O-1 alternately (A, A1, A1/1, and A3 engines).
- The mode T/O can be switched to ALT T/O-1 and back to T/O alternately (A1P and A1/3 engines).
- The modes E T/O, T/O or ALT T/O-1 can be switched alternately (A1E engine).
- The A-ICE initial condition (OFF) can be switched to ON and back to OFF alternately.

5 - START/STOP SELECTOR KNOB

STOP - Commands the FADEC to shut the engine down, provided associated Thrust Lever is at IDLE.

RUN - Allows normal engine operation.

START - This is a momentary position that initiates the engine start cycle. If the knob is held in this position for more than 3 seconds, it becomes inoperative. In this case, a FADEC reset command is required.

NOTE: On airplanes Post-Mod. SB 145-71-0003 or S/N 145.075 and on, each Start/Stop selector knob is equipped with a transparent protection guard over the knob for better engine identification.

OVERHEAD PANEL

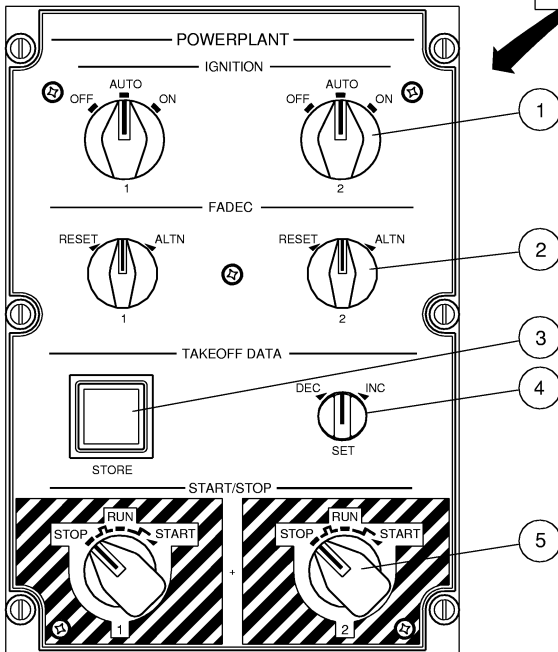
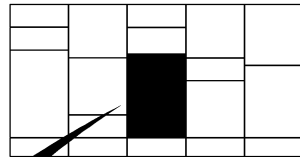

145AOM2100009.MCE

POWERPLANT CONTROL PANEL

2-10-60	Page 4	Code 01
---------	-----------	------------

DECEMBER 20, 2002

AOM-145/1114

FIRE HANDLE

The Fire Handle, located on the Fire Protection Control Panel, allows engine emergency shutdown. For further information on fire controls, refer to Section 2-07 – Fire Protection.

ENGINE INDICATION ON EICAS

1 - N1TARGET INDICATION

- Corresponds to the maximum available engine thrust for a given thrust-rating mode, airspeed, ambient condition, and bleed air status.
- Digits are cyan.
- Ranges from 0 to 100% RPM with a resolution of 0.1%.
- Indicated by a cyan T-shaped bug.
- Indication is removed from the display for request values greater than 100% or less than 0%.

2 - THRUST-RATING MODE ANNUNCIATION

- Indicates the current thrust-rating mode.
- Labels: T/O-1 or ALT T/O-1 (A, A1, A1/1, A3 engines);
T/O or ALT T/O-1 (A1P or A1/3 engines);
E T/O, T/O or ALT T/O-1 (A1E engine);
CON, CLB, or CRZ.
- Color: cyan.
- When engines operate in alternate takeoff mode a green ATTCS annunciation is presented below the takeoff label to indicate that the ATTCS system is armed.

3 - THRUST REVERSER ANNUNCIATION (OPTIONAL)

- Indicates the position of the upper and lower Thrust Reverser doors.
- Label: REV.
- Color:
 - Fully open: green.
 - In transition: amber (if applicable).



4 - N1 INDICATION

- Displays N1 in RPM percentage.
- Scale:
 - Ranges from 0 to 100%. Extends up to 110% if exceeding the red line.
 - Colors: green from 0 to 99.9%.
red line at 99.9%.
- Digits:
 - Ranges from 0 to 120% RPM, with a resolution of 0.1%.
 - Colors: green from 0 to 99.9%.
red at 100.0% and above.

5 - FADEC IN CONTROL ANNUNCIATION

- Indicates the FADEC channel that is controlling the engine.
- Labels: A or B.
- Color: green.

6 - IGNITION CHANNEL ANNUNCIATION

- Indicates the ignition channel that is enabled.
- Labels: IGN A, IGN B, IGN AB, or IGN OFF.
- Color: green.

7 - INTERTURBINE TEMPERATURE INDICATION

- Scale:
 - During engine start:
 - green from 300 to 800°C.
 - red line at 801°C.
 - Takeoff mode:
 - green from 300 to 921°C(A and A1/1 engines).
from 300 to 947°C (A1/3, A1, A1P and A3 engines).
from 300 to 992°C (A1E engine).
 - red line at 922°C (A and A1/1 engines).
at 948°C (A1/3, A1, A1P and A3 engines).
at 993°C (A1E engine)
 - CON, CLB and CRZ modes:
 - green: from 300 to 867°C (A and A1/1 engines).
from 300 to 900°C (A1/3, A1, A1P and A3 engines).
from 300 to 935°C (A1E engine).
 - amber: from 868 to 921°C (A and A1/1 engines).
from 901 to 947°C (A1/3, A1, A1P and A3 engines).
from 936 to 970°C (A1E engine).
 - red line at 922°C (A and A1/1 engines).
at 948°C (A1/3, A1, A1P and A3 engines).
at 971°C (A1E engine).

2-10-60	Page 6	Code 01
---------	-----------	------------

- If the red line is exceeded, the scale extends a further 50°C.
- Digits:
 - Ranges from -65 to 1999°C with a resolution of 1°C.
 - Color: corresponds to the color of the scale.

8 - N2 INDICATION

- Displays N2 in RPM percentage.
- Digits:
 - Ranges from 0 to 120% RPM with a resolution of 0.1%.
 - Colors:
 - EICAS 18.5 and before:
 - green from 0 to 102.4%.
 - red from 102.5% and above.
 - EICAS 19 and on with A1, A1/1, A3, A1/3, A1P engines:
 - green from 0 to 102.5%.
 - red from 102.6% and above.
 - EICAS 19 and on with A1E engines:
 - green from 0 to 103.8%.
 - red from 103.9% and above.

9 - FUEL FLOW INDICATION

- Ranges from 0 to 2000 KPH (or 4000 PPH) with a resolution of 5 KPH (or 10 PPH).
- Color: green.

10 - LOW-PRESSURE AND HIGH-PRESSURE TURBINE VIBRATION INDICATION

- Ranges from 0 to 2.5 inches per second (IPS).
- Low-pressure scale and pointer colors:
 - green from 0 to 1.8 IPS.
 - amber above 1.8 IPS.
- High-pressure scale and pointer colors:
 - green from 0 to 1.1 IPS.
 - amber above 1.1 IPS.

11 - OIL TEMPERATURE INDICATION

- Ranges from 0 to 180°C with a resolution of 1°C.
- Scale, pointer, and digit colors:
 - amber below 21°C.
 - green from 21 to 126°C.
 - red above 126°C.

12 - N1 REQUEST BUG

- Indicates N1 requested by the Thrust Lever position.
- Indicated by a green filled triangle.
- Ranges from 0 to 100% RPM.
- Indication is removed from the display for request values greater than 100% or less than 0%.

13 - OIL PRESSURE INDICATION

Scale, pointer, and digit colors depend on the FADEC version as shown below:

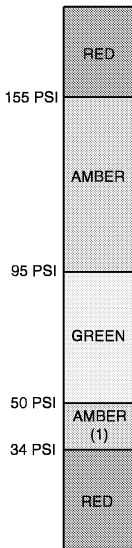

**FADEC B7.5
AND BEFORE**

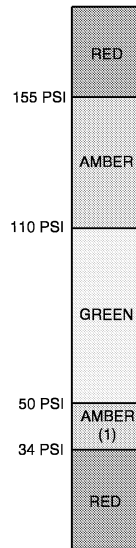

**FADEC B7.6
AND ON**

145AOM1010003.MCE

- (1) For N2 < 88% the amber band between 34 psi and 50 psi does not exist, and the green band lower limit is 34 psi.

EICAS

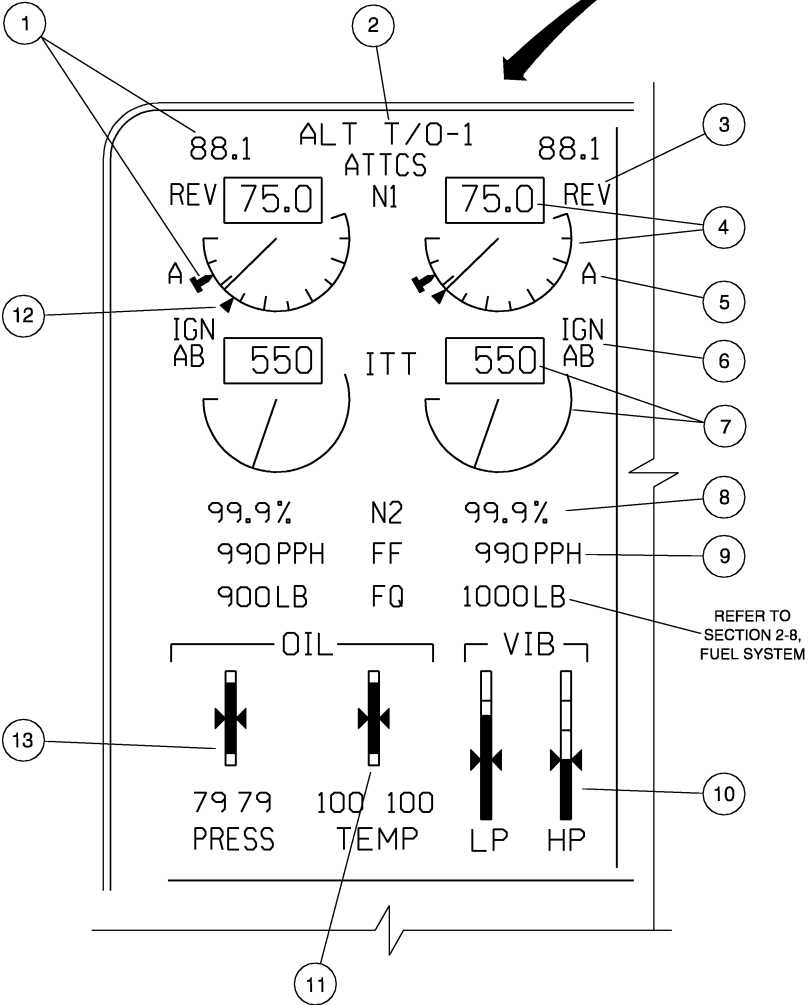
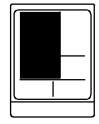

145AOM2100010.MCE

ENGINE INDICATION ON EICAS

AOM-145/1114

DECEMBER 20, 2002

2-10-60	Page 9	Code 01
---------	-----------	------------



TAKEOFF PAGE ON MFD

1 - TAKEOFF MODE INDICATION

- Indicates Takeoff Mode as selected through the Takeoff Data Set Control.
- Labels: T/O-1 or ALT T/O-1 (A, A1, A1/1, A3 engines);
T/O or ALT T/O-1 (A1P or A1/3 engines);
E T/O, T/O or ALT T/O-1 (A1E engine);
- In flight, the indication is removed from the display.

2 - REFERENCE TAKEOFF TEMPERATURE INDICATION

- Indicates reference takeoff temperature as adjusted through the takeoff data set control.
- In flight, the indication is removed from the display.

3 - REFERENCE ANTI-ICE STATUS INDICATION

- Indicates reference anti-ice status as selected through the takeoff data set control.
- Labels: ON or OFF.
- In flight, the indication is removed from the display.

4 - OIL LEVEL INDICATION

- Ranges from 0 to 13 US Quarts for left engine and from 0 to 14 US Quarts for right engine with a resolution of 1 US Quart.
- Digits:
 - green from 6 to 14 US Quarts.
 - amber below 6 US Quarts.

NOTE: The right engine is capable of measuring a higher oil level due to sensor position.

2-10-60	Page 10	Code 01
---------	------------	------------

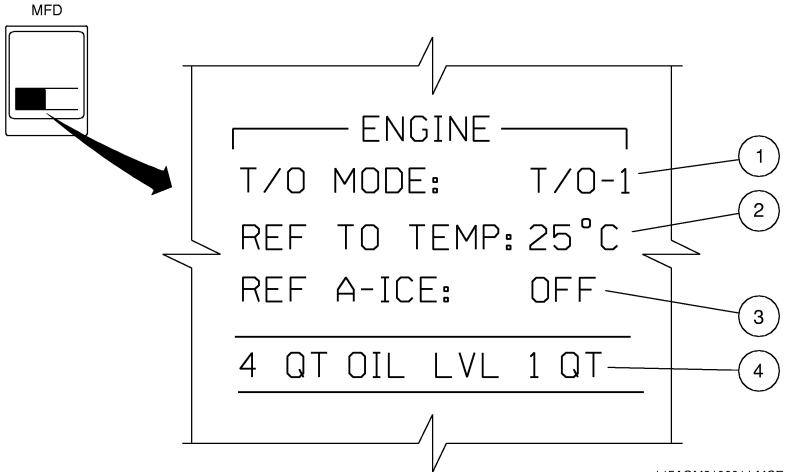

TAKEOFF PAGE ON MFD

FIRST ENGINE BACKUP PAGE ON RMU

- Contains thrust modes, N1, ITT, N2, Fuel Flow, Oil Pressure and Oil Temperature indications.
- Only the N1 indication contains analog and digital indication. The other indications are in digital format.
- Label and legend color: white.
- Data color limits: same as the EICAS display.

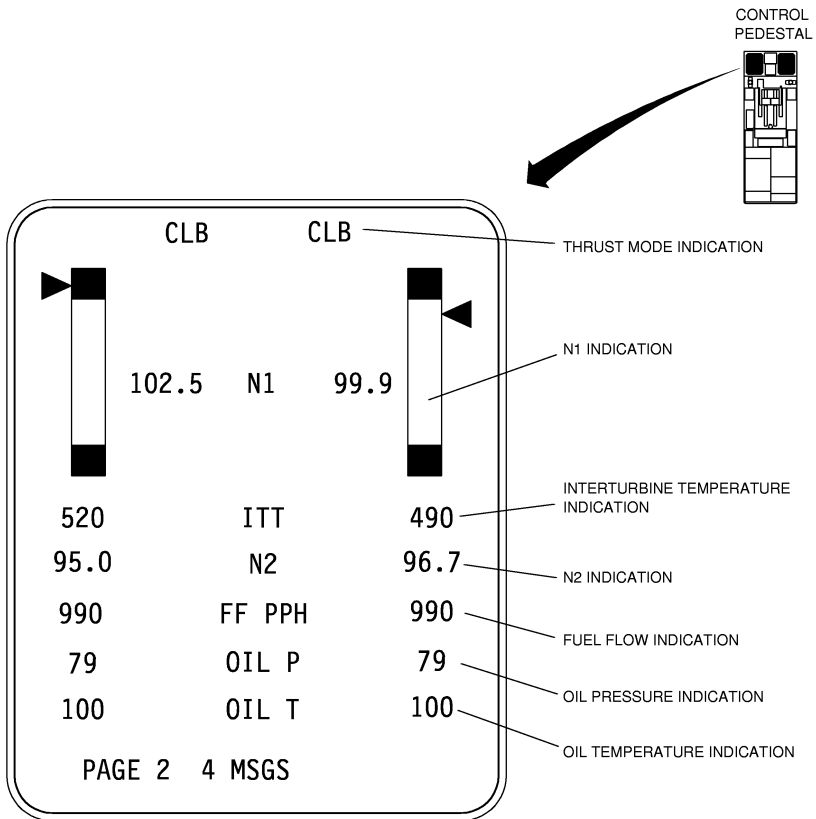

145AOM2100012.MCE

FIRST ENGINE BACKUP PAGE ON RMU

2-10-60	Page 12	Code 01
---------	------------	------------

DECEMBER 20, 2002

THRUST REVERSER (OPTIONAL)

GENERAL

Each engine may be equipped with an optional thrust reverser.

The thrust reverser is for ground operation only, and its function is to direct engine exhaust gases forward and outwards to produce deceleration of the airplane.

The thrust reverser system consists of an electric control/indication, an hydro-mechanical actuation system, and two pivoting doors.

When stowed, the thrust reverser is part of the exhaust nozzle.

LOCK PROTECTION

The system incorporates three locking systems to avoid inadvertent in-flight deployment. The actuators and doors are mechanically locked in the stowed position through the primary and secondary locks. In case the primary and secondary reverser locks fail, the tertiary lock prevents the door from deploying. In the stowed position, the doors are held by the primary lock only, with the secondary and tertiary locks remaining unloaded. The primary and secondary locks are electrically commanded/controlled and hydraulically powered to unlock. The tertiary lock is electrically commanded/controlled and electrically powered to unlock, thus providing a separate and fully independent locking system.

OPERATION

The thrust reverser is commanded by the backward movement of the Thrust Lever. Upon selection, the mechanical locks are removed and hydraulic pressure is applied to deploy the thrust reverser doors. In reverser mode, the doors rotate about a fixed axis. Rotation of the doors is controlled by extension and retraction of the hydraulic door actuators.

After pivoting, the rearmost part of the doors blocks the normal nacelle discharge path and directs the flow through the aperture created by its rotation.

The loss of electrical and/or hydraulic power does not result in inadvertent deployment.

OPERATION LOGIC

Each FADEC will command Maximum Reverse thrust on ground only, when the associated thrust reverser is deployed and associated thrust lever is requesting reverse thrust whenever either of the following conditions are met:

- Airplane on the ground indication from both main landing gears, and main landing gear wheels running above 25 kt, or
- Airplane on the ground indication from both main landing gears and from nose landing gear.

During landing, when the Thrust Levers are set to below IDLE, the FADEC commands reverse thrust only after the Thrust Reverser doors (both engines) are completely deployed. If the Thrust Lever is requesting forward thrust, the FADEC will command IDLE thrust if the associated engine thrust reverser indicates that there is a "not stowed" or a "deployed" condition.

If one engine is inoperative or one thrust reverser is not deployed, the FADEC of the operative side will only command Reverse Thrust if the associated Thrust Lever is requesting reverse thrust and the Thrust Lever of the affected side is set to IDLE. Such a feature is provided to avoid uncommanded thrust asymmetry.

EICAS INDICATION

An indication of right and left thrust reversers deployed is presented on the EICAS. If a failure or a disagreement is detected, a caution message is presented on the EICAS.

THRUST REVERSER INTERLOCK

The FADECs interface with the thrust reverser system of the corresponding engine.

Each FADEC receives two pieces of information from the thrust reverser system:

- Stowed: If all doors of the corresponding engine are stowed.
- Deployed: If all doors of the corresponding engine are deployed.

For flight operation there is also a flat between IDLE and MAX REVERSE position. The FADEC enables reverse thrust depending on the position of the reverser doors and on the position of the engine thrust lever, and reduces the engine thrust to IDLE, if there is an indication of an inadvertent thrust reverser deployment in flight, which normally is not possible due to the Flight Idle electrical stop.

EICAS MESSAGES

TYPE	MESSAGE	MEANING
CAUTION	ENG1 (2) REV FAIL	-Thrust reverser doors not stowed and in transit with Thrust Levers set at or above IDLE, or -Thrust Levers set below IDLE in flight.
	ENG1 (2) REV DISAGREE	-At least one thrust reverser door not fully open, or -Thrust reverser system not isolated from hydraulic system (Thrust Lever set at or above IDLE), or -Door locking or position switch signal failure with Thrust Levers set at or above IDLE (ground only).
ADVISORY	E1 (2) IDL STP FAIL	Idle stop has failed.

**AIRPLANE
OPERATIONS
MANUAL**



THIS PAGE IS LEFT BLANK INTENTIONALLY

2-10-70	Page 4	Code 01
---------	-----------	------------

JUNE 28, 2002

ACM-145/1114

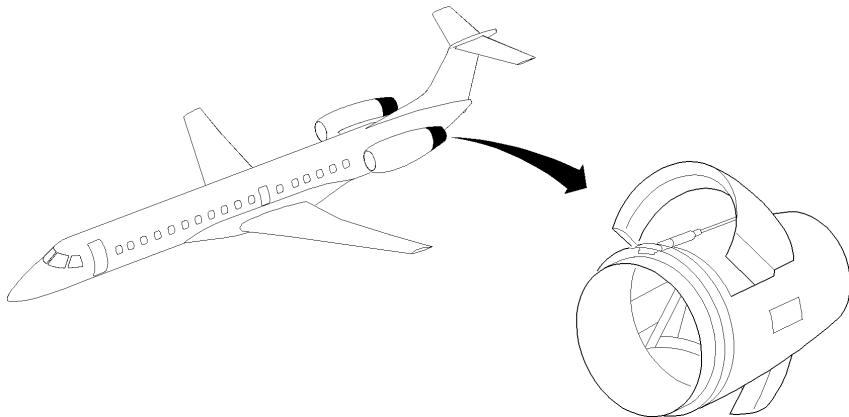

DOORS DEPLOYED

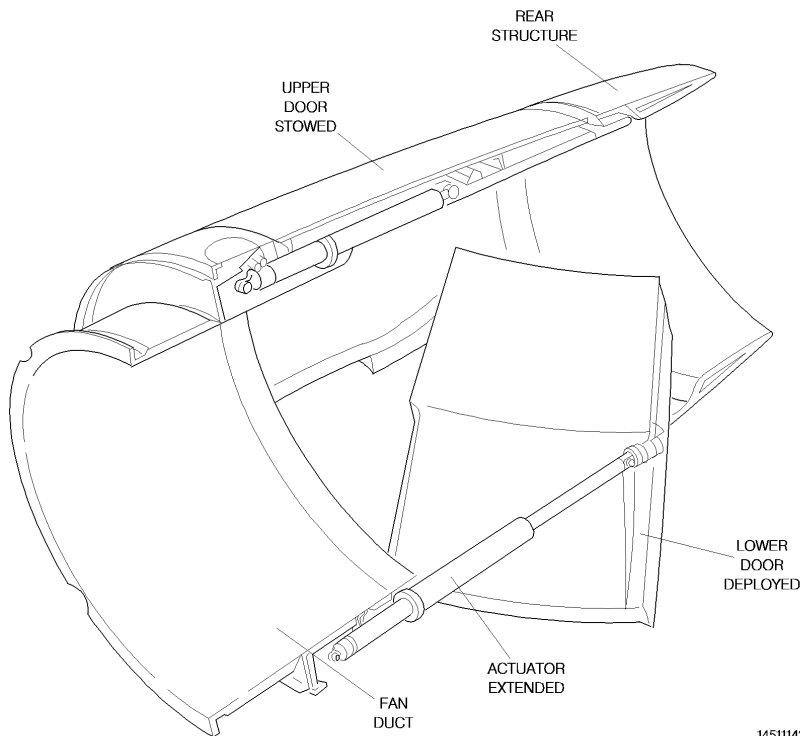

1451114251.MCE

THRUST REVERSER

AOM-145/1114

JUNE 28, 2002

2-10-70	Page 5	Code 01
---------	-----------	------------

**AIRPLANE
OPERATIONS
MANUAL**



THIS PAGE IS LEFT BLANK INTENTIONALLY

2-10-70	Page 6	Code 01
---------	-----------	------------

JUNE 28, 2002

ACM-145/1114