

Commercial Airliner Environmental Control System

Engineering Aspects of Cabin Air Quality

Elwood H. Hunt, Dr. Don H. Reid,
David R. Space, and Dr. Fred E. Tilton

This paper discusses engineering aspects of a modern commercial jet airliner environmental control system (ECS), focusing on cabin air quality. Recent national news media coverage suggests that aircraft cabin air quality is a serious concern. However, an objective review of pertinent data and recent comprehensive testing do not support this perception.

Even more important than “air quality” is “survivability.” Because modern jet airplanes operate in a physical environment that is not survivable by unprotected humans, these airplanes contain a complex ECS. Such systems enable survival, safety, and comfort. Aerospace medical experts are highly cognizant of this fact. ECS engineers study requirements for maintaining human physiological integrity, provided by the aerospace medical community. These requirements are converted into components for environmental control and life support systems. Data from studies of human comfort factors are also applied to the design of these systems. The following discussion reviews the major components of the ECS that sustains human life and comfort during flight.

To illustrate how the ECS works, a volume of air will be followed as it flows continuously from outside the airplane into the airplane cabin and, finally, exits the airplane. The initial conditions and subsequent changes to this volume of air as it travels through each component of the ECS system during various flight phases will be discussed. Figure 1 is a schematic of the ECS components for the Boeing 767 airplane. The 767 is a modern generation airplane that uses 50% filtered recirculated air and 50% outside air. This is typical of modern generation airplanes.

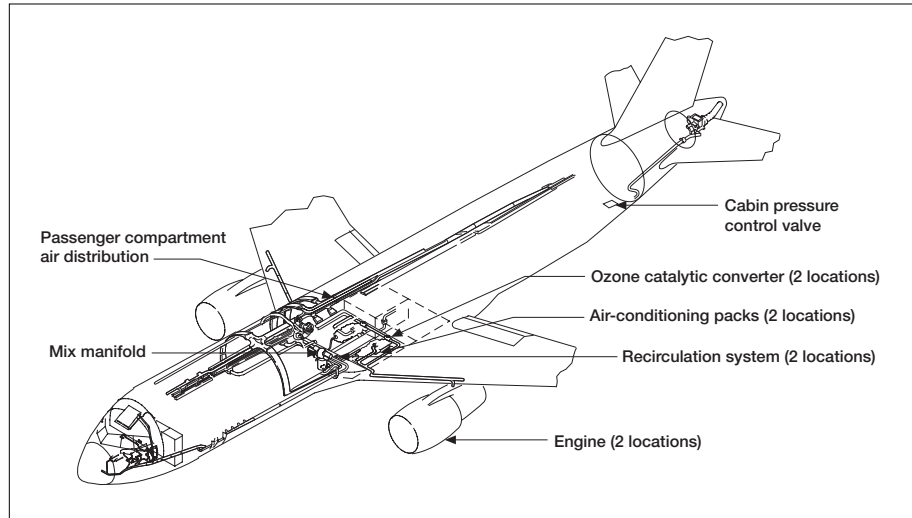

Figure 1. Typical components and system layout for the 767 ECS

Flight Scenario

This discussion is based on a flight scenario from London’s Heathrow (HTH) airport to Los Angeles International (LAX) airport. The airplane is a United Airlines 767-300ER with Pratt & Whitney (P&W) 4000 engines.

Engine

Taxiing from the gate at Heathrow, the outside air temperature is 59°F with an atmospheric pressure of 14.7 pounds per square inch (psi). The airplane engines are at low thrust, pushing the 767 slowly along the taxiway. The P&W 4000 engine is a modern turbofan engine with a “core,” which is the power-generating portion of the engine. The engine also has a “bypass,” which is the main thrust generating portion of the engine, commonly called the “fan.” The core consists of 15 separate compressor stages, a burner section where fuel is added, and six turbine stages where power is extracted to drive the compressor and the fan.

Only about one-fifth of the air drawn into the engine enters the core; the bulk of the air goes through the bypass portion of the engine to produce most of the engine thrust. Figure 2 shows a simplified schematic of the main components of a P&W 4000 engine. This is typical of other modern commercial jet engines.

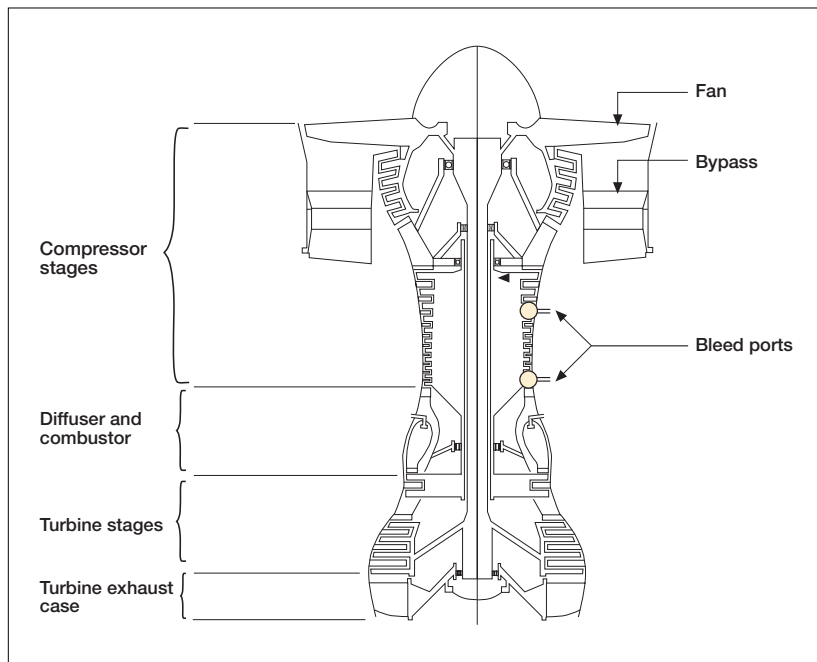

Figure 2. Pratt & Whitney 4000 engine

highest air pressure available from the engine compressor. At low engine power, the high stage is the only source of air at sufficient pressure to meet the needs of the bleed system.

The bleed system consists of a number of valves and a heat exchanger (the precooler). It automatically provides air at the proper temperature and pressure required to meet the needs of all pneumatic services on the airplane. These services include the air-conditioning packs, cabin ventilation system, potable water pressurization, wing and engine anti-ice protection, air-driven hydraulic pump, hydraulic reservoir pressurization, cargo heat, and cabin pressurization. The bleed system is totally automatic, except for a shutoff selection available to the pilots on the overhead panel in the flight deck. A schematic of the 767 bleed system is provided in figure 3.

As the airplane turns onto the runway, the pilots advance the engine thrust to takeoff power. The engine's high stage compressor compresses the air to 1,200°F and 430 psi. This energy level exceeds the requirements for the air-conditioning packs and other pneumatic services—approximately 50% of the total energy available at the high stage port cannot be utilized. However, the bleed system automatically switches to the low stage system, conserving energy.

Bleed System

The bleed system is the heart of the ECS. As outside air enters the compressor stages of the engine core, it is compressed to 32 psi and a temperature of 330°F. Some of this air is then extracted from the engine core through one of two bleed port openings in the side of the engine. Which bleed port extracts the air depends on the positioning of valves that control the bleed ports. One bleed port is at the engine's fifteenth compressor stage, commonly called "high stage." The second is at the eighth compressor stage, commonly called "low" or "intermediate stage." The exact stage can vary depending on engine type. The high stage is the

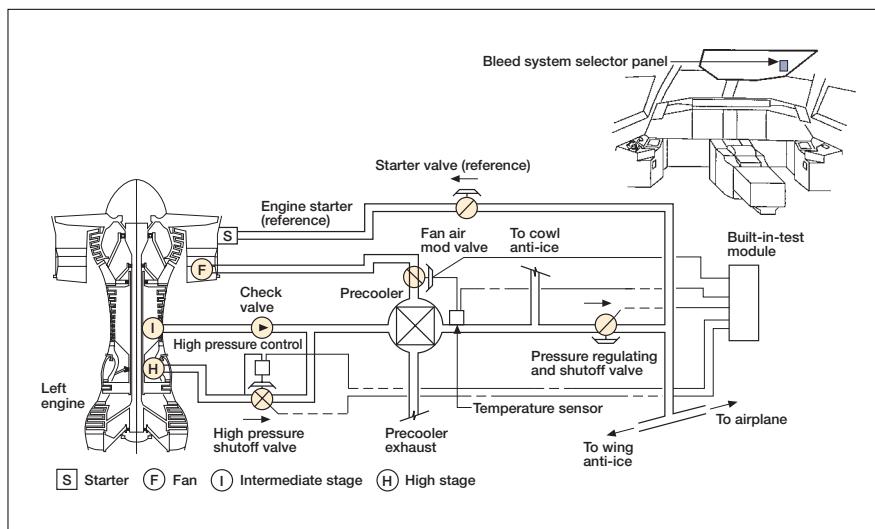

Figure 3. Bleed system

Because the engine must cope with widely varying conditions from ground level to flight at an altitude of up to 43,100 feet, during all seasons, throughout the world, the air at the high or low stage of the engine compressor will seldom exactly match the needs of the pneumatic systems. Excess energy must be discarded as waste heat. The bleed system constantly monitors engine conditions and always selects the least wasteful port. Even so, bleed temperatures often exceed safe levels for delivery to downstream systems. Safe temperature levels are temperatures at which fuel will not “auto” ignite. The function of the precooler is to automatically discharge excess energy back into the atmosphere as waste heat. This ensures that the temperature of the pneumatic manifold is always well below that which could ignite fuel. This is important in the event of a fuel leak.

The airplane climbs to a cruise altitude of 39,000 feet with the outside conditions changing dramatically. Upon reaching cruise altitude, the outside air temperature is -70°F at an atmospheric pressure of 2.9 psi, the partial pressure of oxygen is 0.5 psi. These conditions are not survivable by unprotected human beings. Until the start of descent to LAX, the low compressor stage is able to compress the low pressure cold outside air to a pressure of more than 30 psi and temperature above 400°F . This is all accomplished through the heat of compression—fuel is added only *after* the air has passed through the compressor stages of the engine core.

Figure 4 shows the temperature of the air being extracted from the engine compressor to the bleed system from the time of departure at HTH to the time of arrival at LAX. The temperature of the air supplied to the bleed system far exceeds that required to destroy any microorganisms present in the outside air during any point of the trip. At cruising altitudes, outside air contains very few biological particles of any kind (a few dark fungal spores per cubic meter of air), with higher concentrations at lower altitudes. Because of the high air temperatures from the engine compressor, the air supplied to the air-conditioning packs is sterile.

Leaving the bleed system while in cruise, the volume of air enters the pneumatic manifold at a temperature of 400°F and a pressure of 30 psi. The volume of air now passes through an ozone converter on its way to the air-conditioning packs. The packs are located under the wing at the center of the airplane.

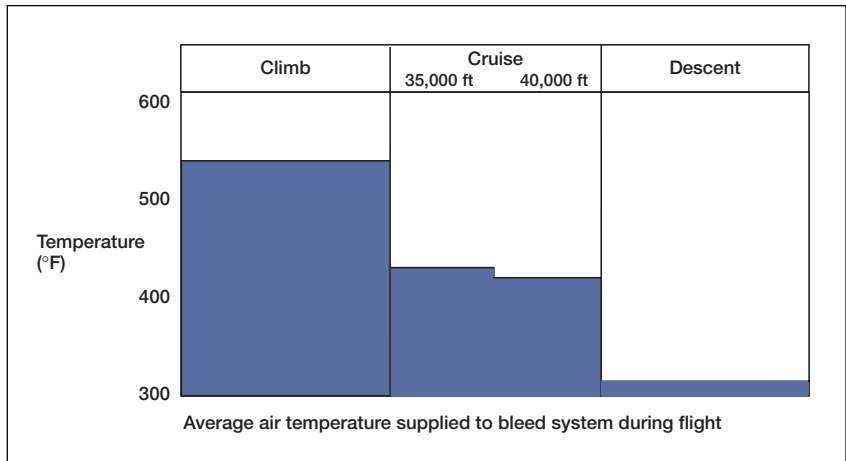

Figure 4. Bleed port air temperature

Ozone Converters

Atmospheric ozone is caused by the photochemical conversion of oxygen by solar ultraviolet radiation. Ozone levels vary with season, altitude, latitude, and weather systems.

While flying at 39,000 feet, several ozone plumes are encountered. Some have ozone concentrations as high as 0.8 parts per million (ppm) or 0.62 ppm sea level equivalent (SLE). This assumes a worst case flight during the month of April, when ozone concentrations are at their highest. If this concentration of ozone were introduced into the cabin, passengers and crew could experience any of the following symptoms: some chest pain, coughing, shortness of breath, fatigue, headaches, nasal congestion, and eye irritation. These are typical symptoms of high ozone exposure.

Atmospheric ozone dissociation occurs when the ozone goes through the compressor stages of the engine, the ozone catalytic converter, and the air-conditioning packs. The ozone further dissociates when contacting airplane ducting, interior surfaces and the airplane recirculation system. The ozone converter dissociates ozone to oxygen molecules by the catalyzing action of a noble catalyst such as palladium. Figure 5 shows a schematic of a 767 ozone converter. A new 767 converter dissociates approximately 95% of the ozone entering the converter to oxygen. It has a useful life of about 12,000 flight hours.

As the volume of air leaves the ozone converter, it is still at 400°F and a pressure of 30 psi. Assuming a worst case, the converter is approaching the end of its useful life with an ozone conversion efficiency of 60%, the ozone concentration leaving the converter is about 0.25 ppm SLE. After this air goes through the air-conditioning packs and is supplied to

the cabin, the ozone concentration in the cabin is about 0.09 ppm. The Federal Aviation Administration (FAA) sets a three-hour time-weighted average ozone concentration limit in the cabin of 0.1 ppm and a peak ozone concentration limit of 0.25 ppm.

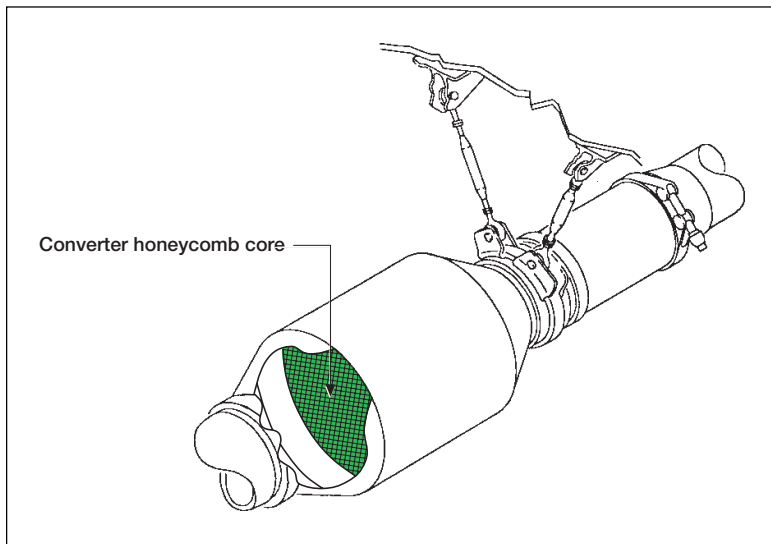

Figure 5. Ozone catalytic converter

Air-Conditioning Packs

The air volume is now entering the air-conditioning packs. An air-conditioning pack is an air cycle refrigeration system that uses the air passing through and into the airplane as the refrigerant. This is accomplished by a combined turbine and compressor machine (commonly called an air cycle machine), valves for temperature and flow control, and heat exchangers using outside air to dispense waste heat.

The air-conditioning pack provides essentially dry, sterile, and dust free conditioned air to the airplane cabin at the proper temperature, flow rate, and pressure to satisfy pressurization and temperature control requirements. For the 767 (and most modern aircraft), this is approximately 5 cubic feet per minute (cfm) per passenger. To ensure redundancy, two air-conditioning packs (two are typical, 747 airplane has three) provide a total of about 10 cfm of

conditioned air per passenger. An equal quantity of filtered recirculated air is mixed with the air from the air-conditioning packs for a total of approximately 20 cfm per passenger. This high quantity of supply air results in a complete cabin air exchange about every two and one-half minutes, or about 25 air changes per hour. The high air exchange rate is necessary to control temperature gradients, prevent stagnant cold areas, maintain air quality, and dissipate smoke and odors in the cabin. Temperature control is the predominant driver of outside airflow requirements.

The automatic controls for the air-conditioning packs constantly monitor airplane flight parameters, flight crew temperature selection for the temperature zones, the cabin zone temperature, and the mixed distribution air temperature. The controls automatically adjust the various valves for a comfortable environment under all normal conditions. The pilot's controls are located on the overhead panel in the flight deck along with the bleed system controls. Normally, pilots are required only to periodically monitor the compartment temperatures from the overhead panel.

Temperatures can be adjusted based on flight attendant reports of passengers being "too hot" or "too cold." Various selections are available to the pilots to accommodate abnormal operational situations.

A schematic of the ECS pack bays containing the air-conditioning packs is shown in figure 6.

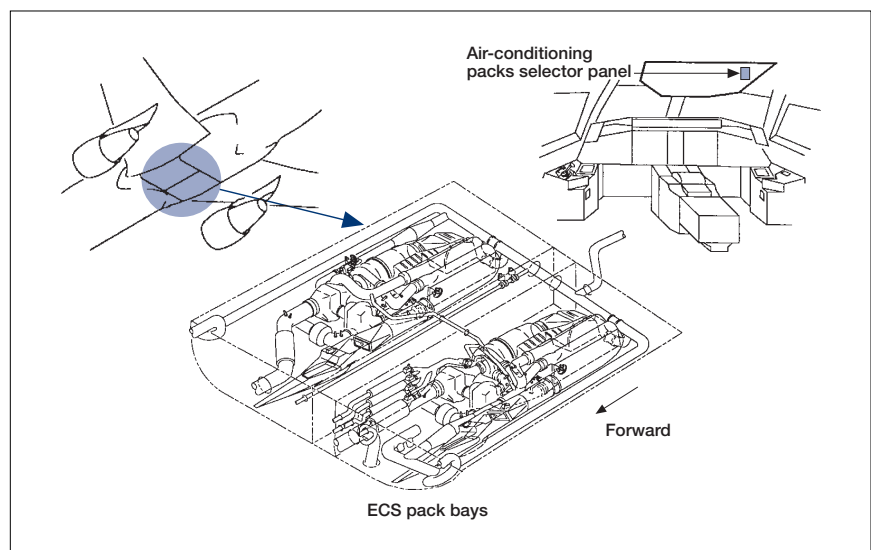

Figure 6. Air-conditioning packs

Mix Manifold

The volume of air has now been cooled by passage through the air-conditioning packs. It leaves the packs at a temperature of 60°F and pressure of 11.8 psi. The relative humidity is less than 5% and ozone concentration is less than 0.25 ppm. The carbon dioxide concentration remains unchanged from that of the outside air at about 350 ppm. As this air enters a mixing chamber, it is combined with an equal quantity of filtered recirculated air. The mixing chamber (called the “mix manifold”) is shown in figure 7.

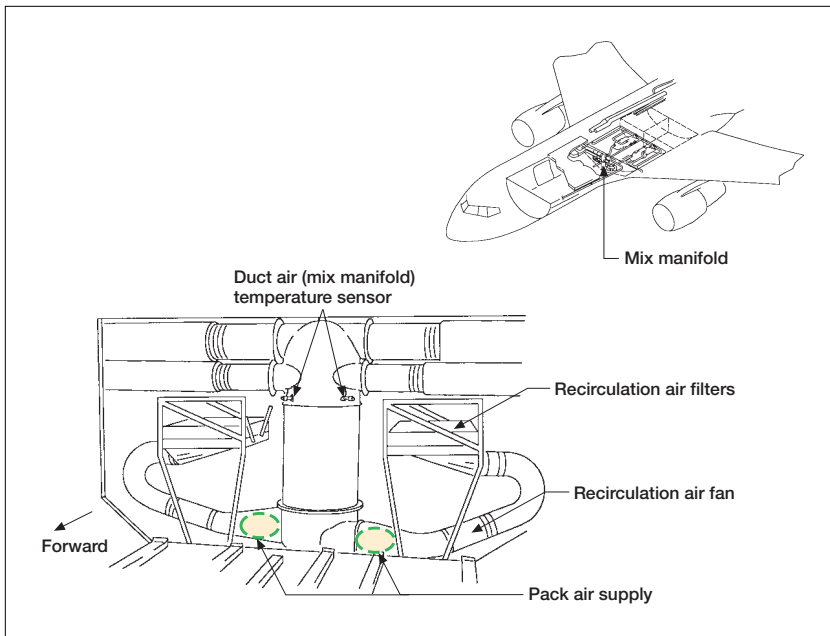

Figure 7. Mix manifold

Recirculation System

The recirculated air entering the mix manifold is essentially sterile. 99.9+% of the bacteria and viruses produced by the passengers has been removed by high-efficiency particulate air type filters (HEPA-type). These filters are used on the 767 airplane and most modern aircraft. They are similar to those used in critical wards of hospitals such as organ transplant and burn wards and industrial clean rooms. The filters are far more effective than those used in other public conveyances or office buildings. The filters cannot be bypassed, and become more efficient with increased service life. They do, however, require replacement at periodic maintenance intervals. As a comparison, figure 8 shows the filter efficiencies of various filtration systems.

Gases are not removed by the filters. Control of gases to very low levels in the cabin is by dilution with high quantities of outside airflow per cubic volume of space. The entire cabin is exchanged with outside air about 12.5 times per hour. The outside air exchange rate for a typical building is 1 to 2.5 times per hour.

Cabin Ventilation System

The air supplied from the mix manifold is separated into ducting “risers” dedicated to each seating zone. The risers take the air from below the floor to the overhead cabin ventilation system. It is then supplied to each seating zone in the airplane. Trim air (hot bleed air from the pneumatic manifold) is added in the risers to increase the air temperature, if needed, to match the required supply air temperature for each seating zone. The supply air temperature per seating zone can vary due to differences in seating densities between seating zones.

The air volume is now entering the cabin ventilation system. This overhead air distribution network runs the length of the cabin. The air is dust free and sterile with a relative humidity of 10% to 20%. The temperature is 65°F to 85°F, depending upon the seating zone the air is being supplied to, and the carbon dioxide concentration is about 1,050 ppm. The increase in carbon dioxide is from passenger respiration.

Due to the large quantity of air entering the relatively small volume of the cabin, as compared to a building, precise control of the airflow patterns is required to give comfort without draftiness. As shown in figure 1, air enters the passenger cabin from overhead distribution outlets that run the length of the cabin. These outlets are designed to create carefully controlled circular airflow patterns in the cabin as shown in figure 9. Air leaves the outlets at a velocity of more than 500 feet per minute (fpm), becomes entrained with cabin air, and maintains sufficient momentum to sweep the cabin walls and floor and wash out any cold pockets of air within the cabin for a comfortable environment. The air direction is oriented to avoid exposed portions of a seated passenger, such as the arms, hands, face, neck, and legs; yet it is of sufficient velocity to avoid the sensation of stagnant air. This requires seated passenger impingement velocities between 20 and 70 fpm.

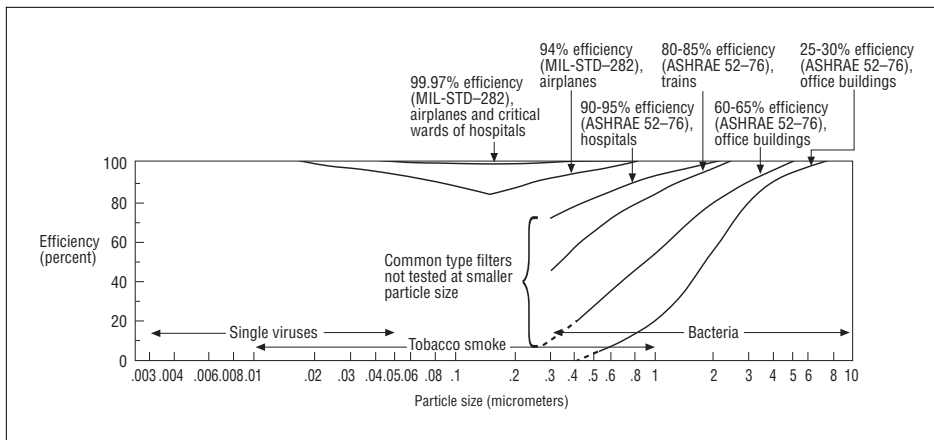

Figure 8. Filter efficiencies of various filtration systems

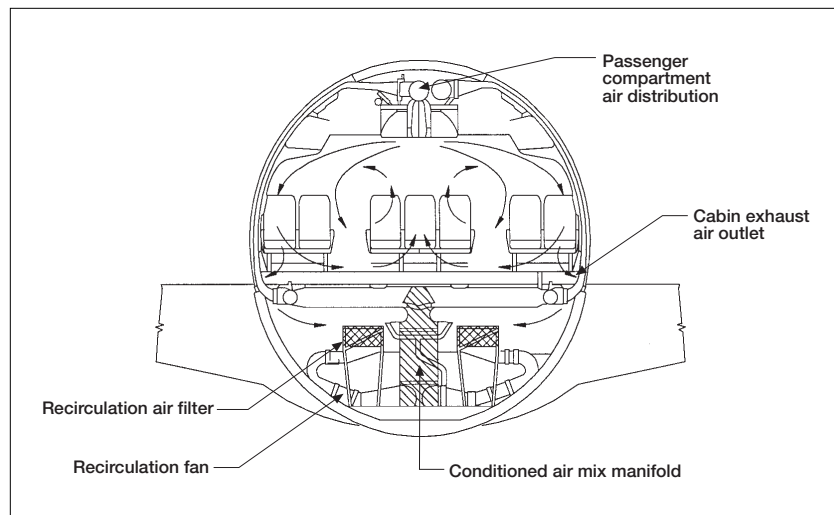

Figure 9. Cabin airflow patterns

The air volume being followed will circulate in the cabin while continuously mixing with cabin air for 2 to 3 minutes, before it is all exhausted through the return air grilles. The return air grilles are located in the sidewalls near the floor and run the length of the cabin along both sides. While this air was in the cabin, about one-third of 1% of the oxygen it contained was consumed by human metabolism, with the oxygen being replaced by an equal quantity of carbon dioxide from passenger respiration. In addition, the return air entrains microorganisms or other contaminants from passengers or the cabin itself. When people cough or sneeze, microorganisms will be entrained in aerosol droplets and exhausted through the return air grilles. Approximately one-half of the return air will be exhausted overboard and the

other half reprocessed to sterile conditions by the recirculation system HEPA-type filters.

The exhaust air is continuously being extracted from beneath the cabin floor. In the aft section, it is being extracted by the cabin pressure outflow valve and exhausted overboard. In the forward section, it is continuously being extracted from below the floor by the recirculation fans for reprocessing by the recirculation filters, then mixed with the outside air being supplied by the air-conditioning packs.

The cabin ventilation system is designed and balanced so that air supplied at one seat row leaves at approximately the same seat row. This minimizes airflow in the fore and aft directions. By controlling fore and aft airflow, the potential for spreading passenger-generated contaminants is minimized.

Cabin Pressure Control System

The cabin pressure control system continuously monitors the airplane's ground and flight modes, altitude, climb, cruise, or descent modes as well as the airplane's holding patterns at various altitudes. It uses this information to allow air to escape continuously from the airplane by further opening or closing the cabin pressure outflow valve in the lower aft fuselage.

The outflow valve is constantly being positioned to maintain cabin pressure as close to sea level as practical, without exceeding a cabin-to-outside pressure differential of 8.60 psi. Figure 10 shows the 767 cabin altitude schedule. At a 39,000-foot cruise altitude, the cabin pressure is equivalent to 6,900 feet or a pressure of 11.5 psi (about 450 feet less than Mexico City). In addition, as the airplane changes altitude, the outflow valve repositions itself to allow more or less air to escape. The resulting cabin altitude is consistent with airplane altitude. This is accomplished within the constraints of keeping pressure changes comfortable for passengers. Normal pressure change rates are 0.26 psi per minute ascending and 0.16 psi per minute descending.

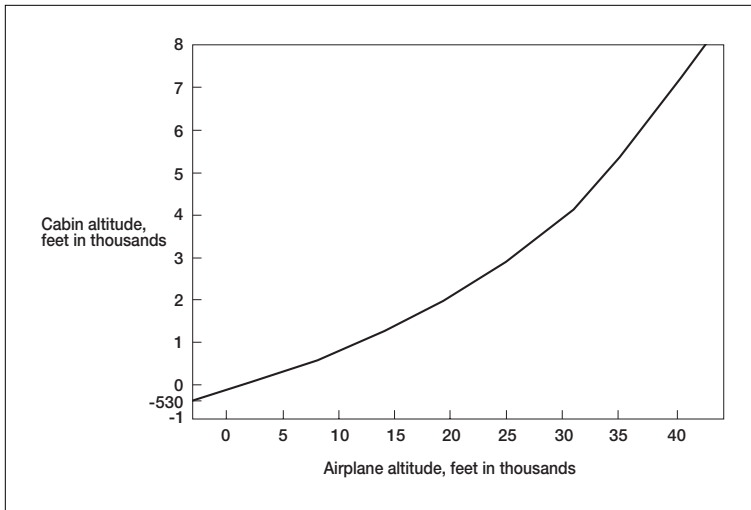

Figure 10. 767 airplane cabin altitude schedule

The cabin pressure control system panel is located in the pilot's overhead panel near the other air-conditioning controls. Normally, the cabin pressure control system is totally automatic, requiring no attention from the pilots. A schematic of the critical components of the cabin pressure control system is provided in figure 11.

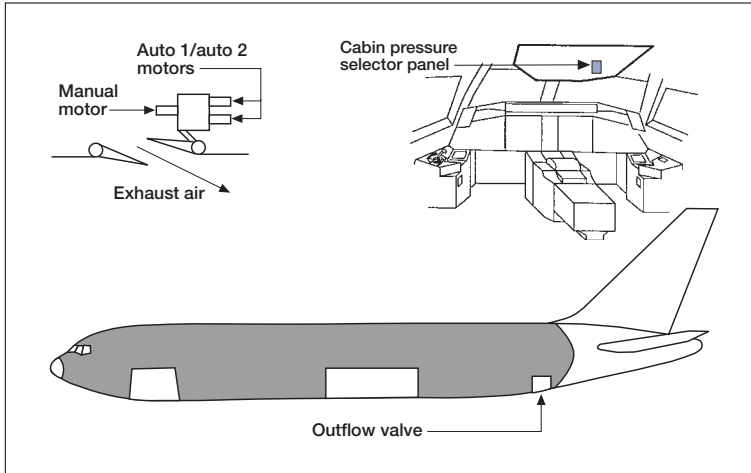

Figure 11. Cabin pressure control system

Comparison of Old and New Generation Commercial Jet Airplanes

At the beginning of the commercial jet airliner age, jet airplanes did not have cabin air recirculation systems, although some turboprops did. The primary reason was that

early jets were powered by highly inefficient turbojet engines. In the turbojet, all of the air entering the engine went through the core. Thrust was obtained by extremely high velocity, high energy turbine exhaust. Fuel consumption was very high, but the additional fuel required to provide outside air to the cabin was very small because the bleed air extraction was a small percentage of the total core airflow.

As engine technology progressed, turbofans were developed with a core bypass ratio of approximately 2 to 1. Fuel economy improved and the cost of engine bleed air relative to overall fuel consumption was still sufficiently small to make 100% bleed air to the passenger cabin cost effective. The economics at the time were also affected by shorter average flight lengths and a lower percentage of direct operating costs attributed to fuel than today.

As modern turbofan engines with high 5 to 1 bypass ratios were developed, fuel consumption to provide engine thrust decreased. However, the fuel consumption relative to extracting bleed air dramatically increased, almost in direct proportion to the higher bypass ratio. For a 767 with P&W 4000 engines, the percent increase in fuel consumption due to bleed air only would be almost four times higher than an equivalently sized turbojet

for the same amount of bleed air. This is shown graphically in figure 12. Eliminating the recirculation system on modern airplanes and supplying 100% outside air to the cabin would have wasted more than 40 million gallons of fuel for the 767 fleet to date—without a definable benefit. Converted into barrels of crude oil necessary to extract the jet fuel, this would have required a minimum of 14 additional super tankers to supply fuel for the 767 fleet.

Highly efficient recirculation systems were developed from studies conducted with the National Aeronautics and Space Administration (NASA), the McDonnell Douglas Aircraft company, and an airline. The studies indicated that substantial fuel could be saved without compromising cabin air quality. This was accomplished by utilizing recirculation systems equipped with highly efficient filters and correspondingly reducing the bleed air.

Filtered recirculation conserves energy. Office buildings typically recirculate 65% to 95% of the air, depending on outside temperatures. Buildings use far less efficient recirculation filters than do airplanes, as shown in figure 8.

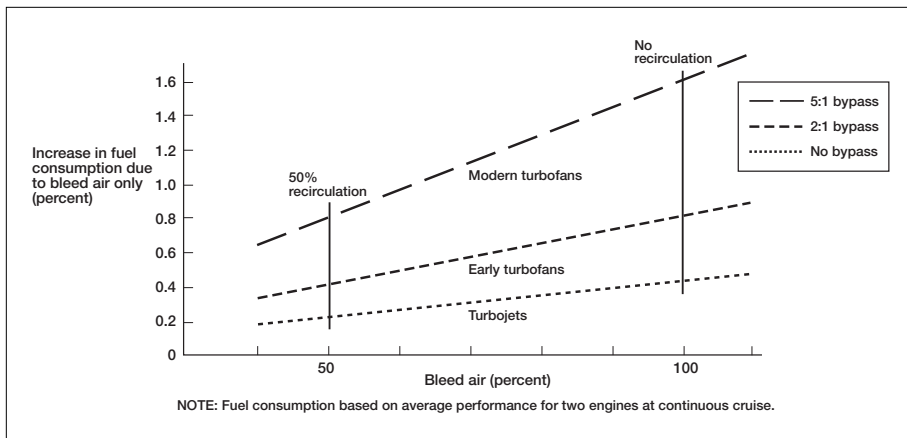

Figure 12. Increase in bleed air fuel consumption with modern jet engines

Item	Average measured (ppm)	ACGIH (ppm)	ASHRAE (ppm)	Comments
CO ₂ ^{a, b}	600 – 1,500	5,000	1,000	ASHRAE value is a surrogate for body odor
CO ^a	0.6/1.4	25	–	Average nonsmoking zone/smoking zone
Microbial ^a aerosols	Very low	–	–	Equal to or lower than in the common home
Ozone ^a	0.02	0.1	0.05	
Particulates ^a	40/175 RSP	10,000 TSP	260 TSP	µg/m ³ , nonsmoking/smoking zones
NO ₂ ^b	Very low	3	–	
SO ₂	Very low	2	–	
Volatile organic ^{b, c} compounds	1.8 – 3.2	1,000	–	Too low to quantify, except during food service when ethanol (alcohol) was served

RSP - respirable suspended particulate
TSP - total suspended particulate
ACGIH values are time weighted average—8-hour workday, 40-hour workweek
ASHRAE - American Society of Heating, Refrigerating and Air-Conditioning Engineers
ACGIH - American Conference of Governmental Industrial Hygienists

a. United States Department of Transportation report no. DOT-P-15-89-5, Airliner Cabin Environment: Contaminant Measurements, Health Risks and Mitigation Options, December 1989
b. National Institute for Occupational Safety and Health, HETA 90-226-2281, Health Hazard Evaluation Report, Alaska Airlines, January 1993
c. Manufacturer testing

Table 1. Test results of cabin air quality studies

Cabin Air Quality Test Results

Credible scientific investigations of cabin air quality have been conducted by the National Academy of Sciences, United States Department of Transportation (DOT), National Institute for Occupational Safety and Health (NIOSH), Centers for Disease Control and Prevention (CDC), independent research groups, and airplane manufacturers. Results of these studies are provided in table 1. The results show very high air quality in the passenger cabin of airplanes. This is no surprise considering how an airplane ECS works.

The CDC recently completed several investigations on the spread of tuberculosis (TB) in commercial jet airliners. In March 1995, a CDC report concluded that airplane filters

are able to filter out TB bacteria from the recirculation air. The chance of transmission on airplanes is low risk and no greater than on other forms of public transportation for the same time duration. The investigation also found that air exchange rates in the airplane cabin exceed the number recommended for hospital isolation rooms used to isolate patients with infectious TB.

Conclusion

The ECS on modern commercial jet airliners has evolved from the early commercial aviation days when airplanes were not pressurized and altitude was limited, to the state-of-the-art environmental control and life support systems of today. The hostile conditions existing at modern cruise altitudes are no more survivable than those encountered by submarines at extreme ocean depths. As explored here, complex aircraft features allow conversion of the extremely hostile conditions outside the jetliner's shell to a comfortable, safe environment inside. Cold, high-altitude air is brought into the airplane and converted to a comfortable, life-supporting medium.

Popular misconceptions about cabin air quality fail to understand the high degree of quality with which a volume of air is maintained from the time it enters the aircraft's engines to the time it is expelled overboard. All of the processes involved maintain or reestablish the purity of the air volume. The results of many cabin air quality tests reinforce this conclusion. As this brief paper illustrates, the ECS of today's jetliners is carefully engineered to provide superior cabin air quality.



This is a preliminary paper and was presented at the Aerospace Medical Association annual meeting, Anaheim, California, May 1995.