

Bombardier Challenger 605 - Ice & Rain Protection

GENERAL

There are four anti-iced areas on the Challenger 605:

- Wing leading edges;
- Engine cowls;
- Windshields and windows; and
- Air data probes.

The wing leading edges and the engine intake cowls are anti-iced using engine 14th-stage bleed air. The windshields, windows and air data probes are anti-iced using electrical power. An ice detector system provides EICAS indications of ice accumulation.

Anti-icing of the aircraft tail surfaces is not required.

WING ANTI-ICE SYSTEM

Description

The left and right wing leading edges are anti-iced using pressure-regulated 14th-stage bleed air, distributed by wing anti-ice ducting and piccolo tubes. The system is controlled by the WING ANTI-ICE switch, located on the ANTI-ICE panel. The WING ANTI-ICE switch normally controls the left and right wing anti-ice valves, via wing-mounted control sensors and the wing anti-ice controller. An isolation valve allows both wings to be anti-iced from a single bleed source via a crossover duct. Panel lights and EICAS messages provide indications of system status during operation.

WING ANTI-ICE SYSTEM (CONT'D)

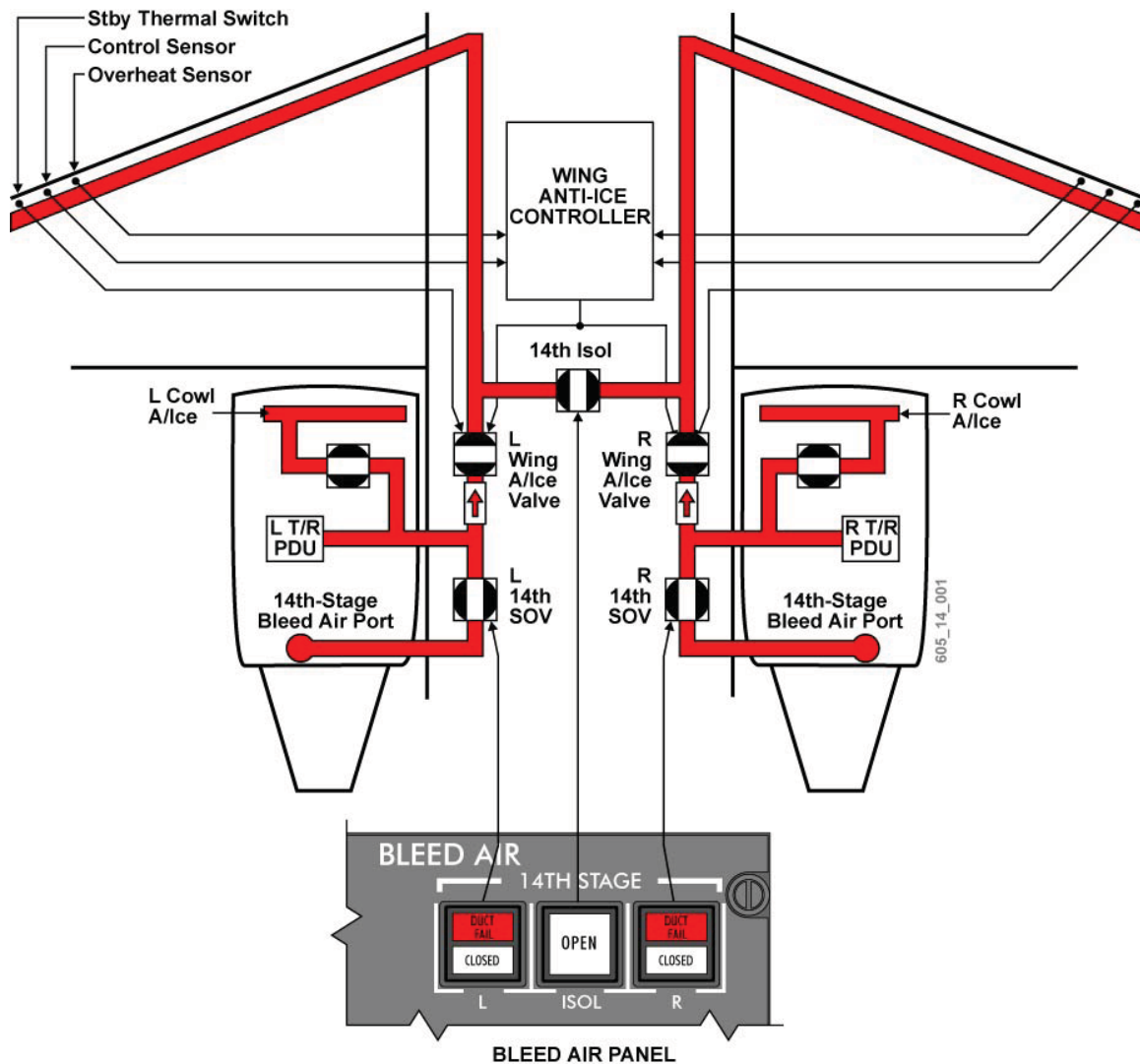

Wing Anti-Ice System
Figure 14-10-1

Components and Operation

Anti-Ice Ducts

Bleed air, taken from the 14th-stage bleed air manifold, is ducted to the wing and ejected from the piccolo tubes onto the inner surfaces of the leading edges. After heating the leading edges, the air is exhausted overboard through louvers located beneath each wing leading edge. The piccolo tubes extend the full length of the leading edges.

WING ANTI-ICE SYSTEM (CONT'D)

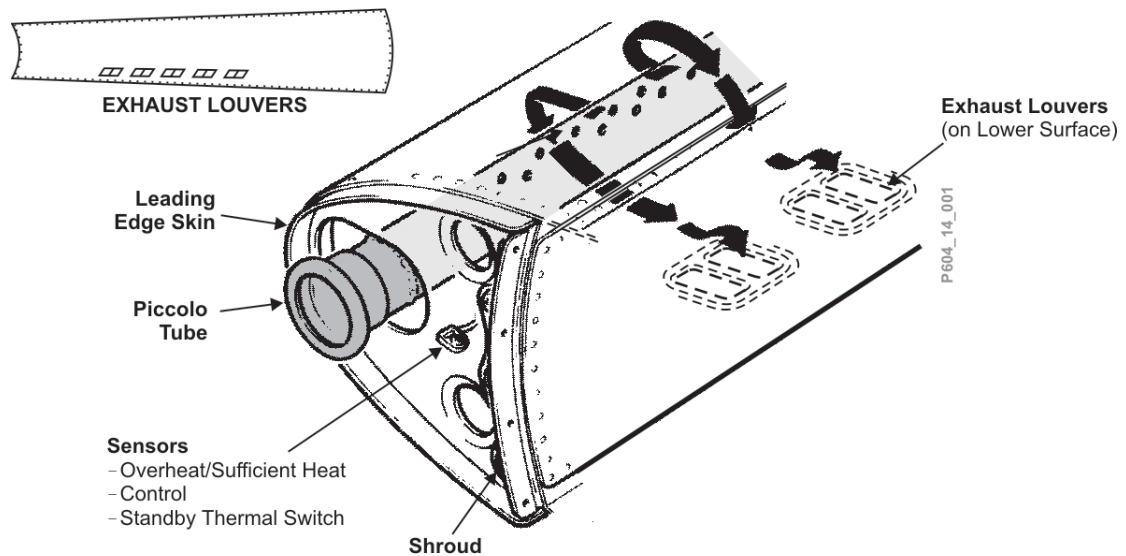

Wing Anti-Ice Components
Figure 14-10-2

Wing Anti-Ice Valves

The left and right wing anti-ice valves are electrically controlled, pneumatically operated, pressure-regulating shutoff valves. The valves are spring-loaded to the closed position when no 14th-stage pressure is available, or electrical control power is lost. The wing anti-ice system is normally operated in the NORM mode. A backup mode (STBY mode) exists should NORM mode fail. The valves are set to regulate at 35 ± 5 psig. During modulation, the regulated pressure will be lower than this value.

Wing Anti-Ice Controller

The wing anti-ice controller maintains the temperature of the left and right wing leading edges when NORM mode is selected. The wing anti-ice controller is bypassed when STBY mode is selected.

NORM Mode

When the WING ANTI-ICE switch is selected to the NORM position, the wing leading edge temperatures are continuously monitored by their respective control sensor. The wing anti-ice controller modulates both wing anti-ice valves simultaneously to maintain a constant wing leading edge temperature ($88^{\circ}\text{C}/190^{\circ}\text{F}$).

The green L HEAT/R HEAT lights, located on the ANTI-ICE panel, will illuminate when the respective wing leading edge is sufficiently heated to prevent ice accumulation (above $29^{\circ}\text{C}/85^{\circ}\text{F}$).

WING ANTI-ICE SYSTEM (CONT'D)

STBY Mode

When the WING ANTI-ICE switch is selected to the STBY position, the wing anti-ice controller is bypassed, and both wing anti-ice valves are independently controlled by their respective standby thermal switch. The valves will cycle either fully open or fully closed, to maintain the wing leading edge temperature within a predetermined temperature range (49°C/120°F and 82°C /180°F).

Wing Overheat

Should a wing leading edge reach a temperature of 129°C/265°F or greater, the **WING OVHT** warning EICAS message will appear, accompanied by the “WING OVERHEAT” voice warning and the flashing MASTER WARNING lights. Once the temperature drops below this value, the **WING OVHT** warning message will be removed.

14th-Stage Isolation Valve

The isolation valve allows both wings to be anti-iced from a single source, by using the crossover duct. The 14th-stage isolation valve is normally closed during wing anti-icing. Should a wing anti-ice valve fail, or if an engine is not capable of supplying 14th-stage bleed air, the isolation valve can be selected open by the flight crew, allowing the operative system to anti-ice both wings.

The 14th-stage isolation valve is pneumatically operated and electrically controlled by the 14th-stage ISOL switch/light on the BLEED AIR panel. Valve status is indicated by a switch/light OPEN annunciation (see Figure 14–10–1).

The isolation valve is spring-loaded to the closed position when no 14th-stage bleed air is available, or electrical power control is lost.

Thrust Reverser Override Function

The 14th-stage bleed air cannot simultaneously supply the demands of the thrust reverser and the wing anti-ice system. Therefore, the wing anti-ice system is automatically disabled upon thrust reverser operation. The EICAS caution messages for wing anti-ice are inhibited during thrust reverser operation.

ENGINE COWL ANTI-ICE SYSTEM

Description

The engine cowl anti-ice system prevents ice formation on the cowl leading edges and the T2 probe at the engine inlet, using pressure-regulated 14th-stage bleed air.

The bleed air is ducted to the T2 probe and to the cowl leading edges from the cowl anti-ice valve and the ejector. The ejector circulates the air within the cowl with air ejected from the piccolo tubes onto the inner surfaces of the leading edge. After heating the cowl leading edges, the air is exhausted overboard through a louvered exit at the bottom of the engine nacelle.

The L (R) COWL ANTI-ICE switch/lights, located on the ANTI-ICE panel, control the left and right engine cowl anti-ice valves respectively.

ENGINE COWL ANTI-ICE SYSTEM (CONT'D)

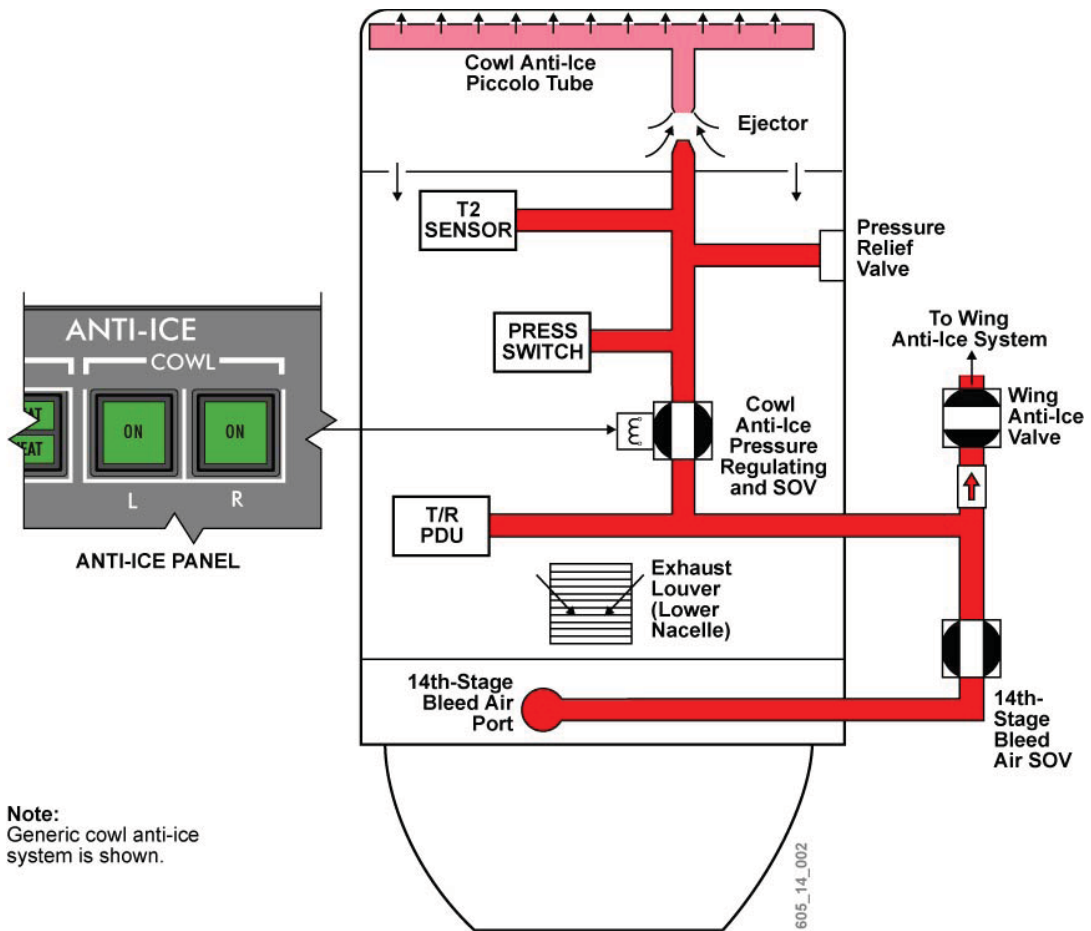

Cowl Anti-Ice System
Figure 14-10-3

Components and Operation

Cowl Anti-Ice Valves

The cowl anti-ice valves are electrically controlled, pneumatically operated, pressure-regulating shutoff valves. The valves reduce the high 14th-stage bleed air pressure to a level suitable for anti-icing of the engine intake cowl and T2 probe. The valves are fail-safed to the open position. Therefore, if electrical power is lost, and bleed air is available, the cowl anti-ice valves will move to the open position.

Selecting a COWL switch/light commands the corresponding cowl anti-ice valve to open. When the valve opens, the COWL switch/light illuminates when sufficient pressure is sensed by the pressure switch, and the **COWL A/ICE ON** advisory EICAS message appears.

If the cowl anti-ice valve fails to open, the **L (R) COWL A/ICE** caution EICAS message will be displayed, indicating insufficient pressure.

ENGINE COWL ANTI-ICE SYSTEM (CONT'D)

When the COWL switch/light is deselected, the cowl anti-ice valve is commanded to close. Should the cowl anti-ice valve remain in the open position (as sensed by the pressure switch), the **L (R) COWL A/ICE** caution EICAS message will be displayed, indicating bleed pressure in the system (valve failed to close).

Pressure Relief Valves

The pressure relief valves provide overpressure protection in the event of cowl anti-ice valve malfunction. When an overpressure condition occurs, the respective relief valve plunger extends, dumping excess pressure overboard. When extended, the relief valve plunger is visible from the ground during external walkaround.

Thrust Reverser Override Function

The cowl anti-ice system is automatically disabled upon thrust reverser operation, since the 14th-stage bleed air cannot simultaneously supply the demands of the thrust reverser and the cowl anti-ice system. The EICAS caution messages for the cowl anti-ice system are inhibited during thrust reverser operation.

WINDSHIELD/WINDOW ANTI-ICE SYSTEM

Description

The windshield/window anti-ice system provides a dual-temperature heating function on the windshield (LOW and HI), and a single-temperature heating function on the side windows (LOW).

When HI is selected, heating of the windshield provides an anti-ice capability on the outer panel, while also providing a moderate defogging function on the inner surface. The LOW setting provides defogging to the windshield and window.

WINDSHIELD/WINDOW ANTI-ICE SYSTEM (CONT'D)

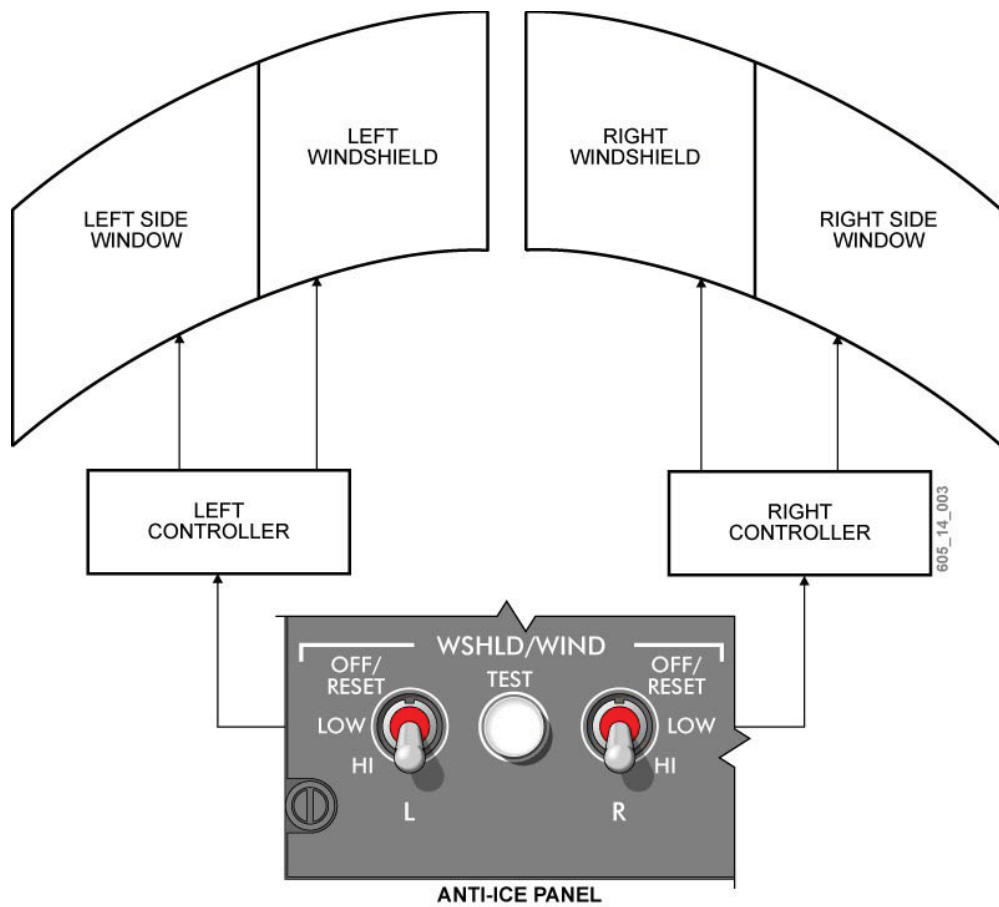

Windshield/Window Anti-Ice System
Figure 14-10-4

Components and Operation

Windshield and Window Construction

The forward-facing windshields and side windows are constructed of two vinyl layers, separated by a vinyl inner layer. Each windshield and window incorporates electrical resistance coatings that provide heat for anti-icing the windshields, and low heat for defogging the side windows. Temperature sensors and temperature controllers for each windshield and window regulate system temperature to maintain a scheduled surface temperature.

Control Switches and Function

The L and R WSHLD/WIND switches, located on the ANTI-ICE panel, control the windshield/window anti-ice system. The L WSHLD/WIND switch controls the left windshield and window. The R WSHLD/WIND switch controls the right windshield and window.

When the WSHLD/WIND switch is set to LOW, the corresponding windshield and side window will be controlled at the low heat level (41°C/106°F).

WINDSHIELD/WINDOW ANTI-ICE SYSTEM (CONT'D)

When the WSHLD/WIND switch is set to HI, the controllers and sensors operate to maintain a high heat level (58°C/137°F) on the corresponding windshield, and a low heat level (41°C/106°F) on the corresponding side window.

Overheat protection circuits for each windshield or window remove power from the affected surface during an overheat condition. The applicable **L (R) WSHLD HEAT**, **L (R) WINDOW HEAT** caution EICAS message will also be displayed. Moving the WSHLD/WIND switch to the OFF/RESET position de-energizes the applicable windshield and window, and resets the temperature controller.

System Test

The TEST switch is used to test the windshield and window anti-ice systems. With both WSHLD/WIND switches in the HI position, depressing the TEST switch performs a test of the windshield and window heat systems. A successful test is indicated by the **L (R) WSHLD HEAT OK** and **L (R) WINDOW HEAT OK** advisory EICAS messages appearing.

With the WSHLD/WIND switches in the LOW position, only the side window heat system will be tested.

AIR DATA PROBES AND SENSORS ANTI-ICING

Description

The air data probes and sensors are located on either side of the aircraft nose, and are electrically heated to prevent ice formation. Two air data sensor heat controllers (ADSHCs) provide control and monitoring of the probe heaters.

Two probe toggle switches, located on the ANTI-ICE panel, provide control of AC power to the left side and right side heating elements. Activation of the heating elements is determined by probe switch positions, engine generator operation, and passenger door status.

AIR DATA PROBES AND SENSORS ANTI-ICING (CONT'D)

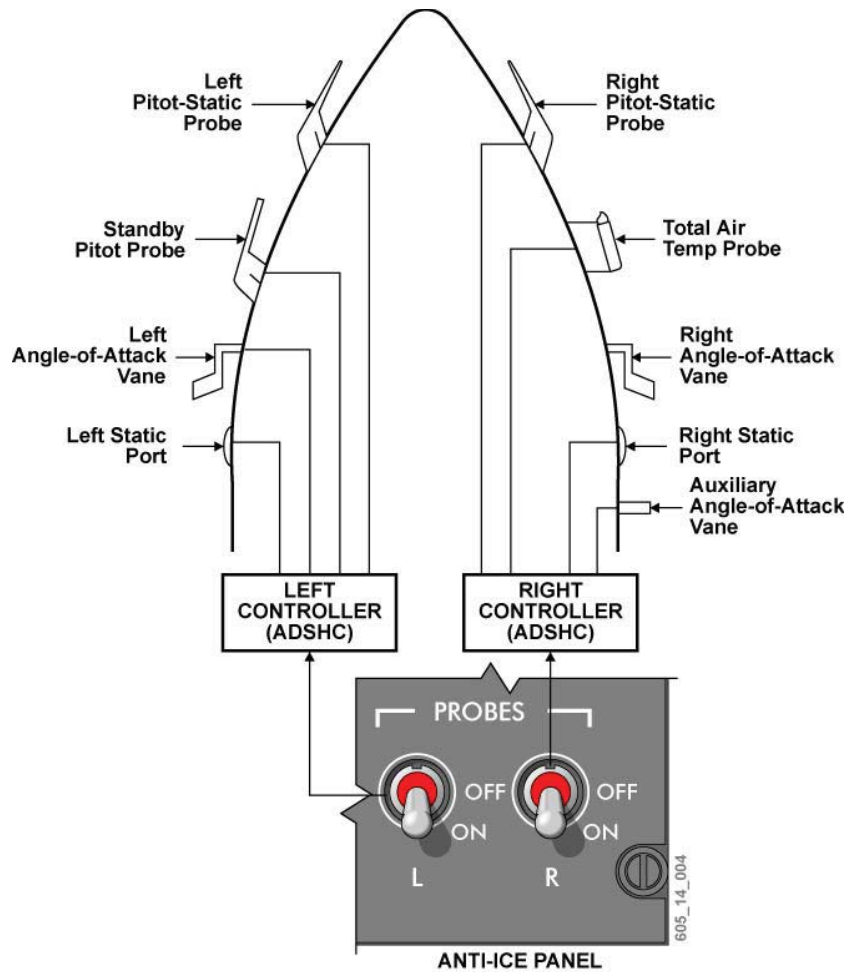

Air Data Probes and Sensors Anti-Icing System
Figure 14-10-5

Components and Operation

Primary Pitot-Static Probes

There are two pitot-static masts, one on either side of the nose. The pitot-static mast consists of a head and mounting base. The mast has two heaters, one in the head and the other in the base.

Standby Pitot Probe

There is one standby pitot probe on the left side of the nose, which contains one integral heating element.

AIR DATA PROBES AND SENSORS ANTI-ICING (CONT'D)

Alternate Static Ports

Two flush alternate static ports are located on each side of the aircraft, and each contains an integral heating element.

Angle-of-Attack (AOA) Vanes

Two angle-of-attack vanes are located on each side of the aircraft, and each contains an integral heating element in the vane.

Auxiliary Angle-of-Attack Vane

One auxiliary angle-of-attack vane is located on the right side of the nose, and contains two integral heating elements, one for the vane and the other for the base.

Total Air Temperature (TAT) Probe

One total air temperature sensor is located on the right of the aircraft, and contains an integral heating element.

Air Data Sensor Heat Controllers (ADSHCs)

The ADSHCs provide control of AC power to respective heating elements, and also detect system failures. Should any ADSHC lose control power, all probes connected to the failed ADSHC will receive full AC power (fail-safe ON). Should a fault condition be detected by any ADSHC, the applicable EICAS caution message(s) will be displayed.

Probe Switches

The L and R PROBES switches are used to control AC power to the probe heaters via the ADSHCs. The L PROBES switch controls the left pitot-static probe, the standby pitot probe, the left angle-of-attack vane and the left static port. The R PROBES switch controls the right pitot-static probe, the total air temperature probe, the right angle-of-attack vane, the right static port and the auxiliary angle-of-attack probe.

Electrical power is applied to the respective heaters under the following conditions:

- L (R) PROBES switch ON; and
- Any one engine generator on-line or PAX door is locked.

With the L and R PROBES switches selected ON, all probes are heated and no EICAS caution messages are displayed.

ICE DETECTION SYSTEM

Description

The ice detection system alerts the flight crew of icing conditions. The system consists of two independent ice detector/microprocessors, one installed on each side of the forward fuselage.

ICE DETECTION SYSTEM (CONT'D)

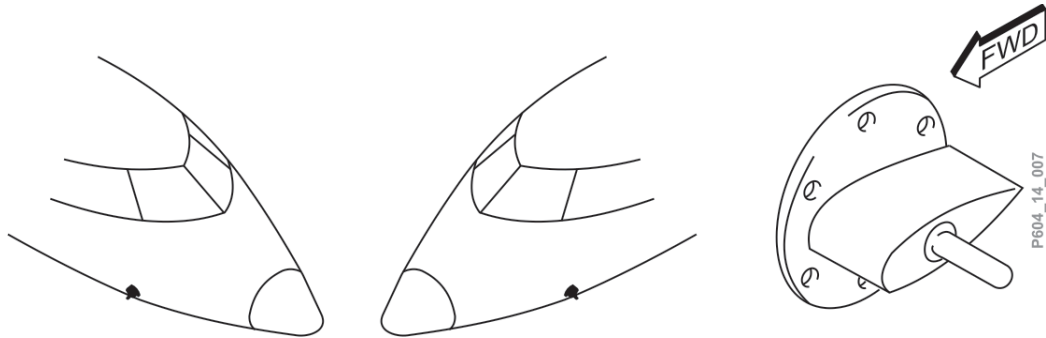

Ice Detectors
Figure 14-10-6

Components and Operation

Each ice detector consists of a probe and a microprocessor, which operate continuously (no switch control). The probe extends into the airstream to detect icing conditions. The microprocessor is a self-contained unit, and interfaces with the data concentrator units (DCUs) to provide the flight crew with a visual indication of icing conditions.

The ice detector probes vibrate at high frequency. When icing conditions are encountered, ice accumulation on the probe causes a frequency change in the probe. The microprocessor detects the frequency change, triggers an **ICE** advisory or **ICE** caution EICAS message, and begins the probe's deicing cycle. During probe deicing, the probe is electrically heated for 5 seconds, followed by 55 seconds with no heat. The cycle repeats automatically as long as a frequency change is detected. When no ice accumulation is detected, the heat cycle ceases and the ICE message on the EICAS is removed.

Ice Detection Test

Selecting the TEST switch on the ANTI-ICE panel to the DET position checks the circuitry of the ice detectors.

CONTROLS AND INDICATORS

The ANTI-ICE panel provides the system control switches and switch/lights, and the EICAS page provides the system warning/caution and advisory messages respectively.

CONTROLS AND INDICATORS (CONT'D)

ANTI-ICE Panel

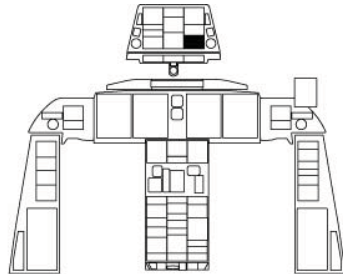
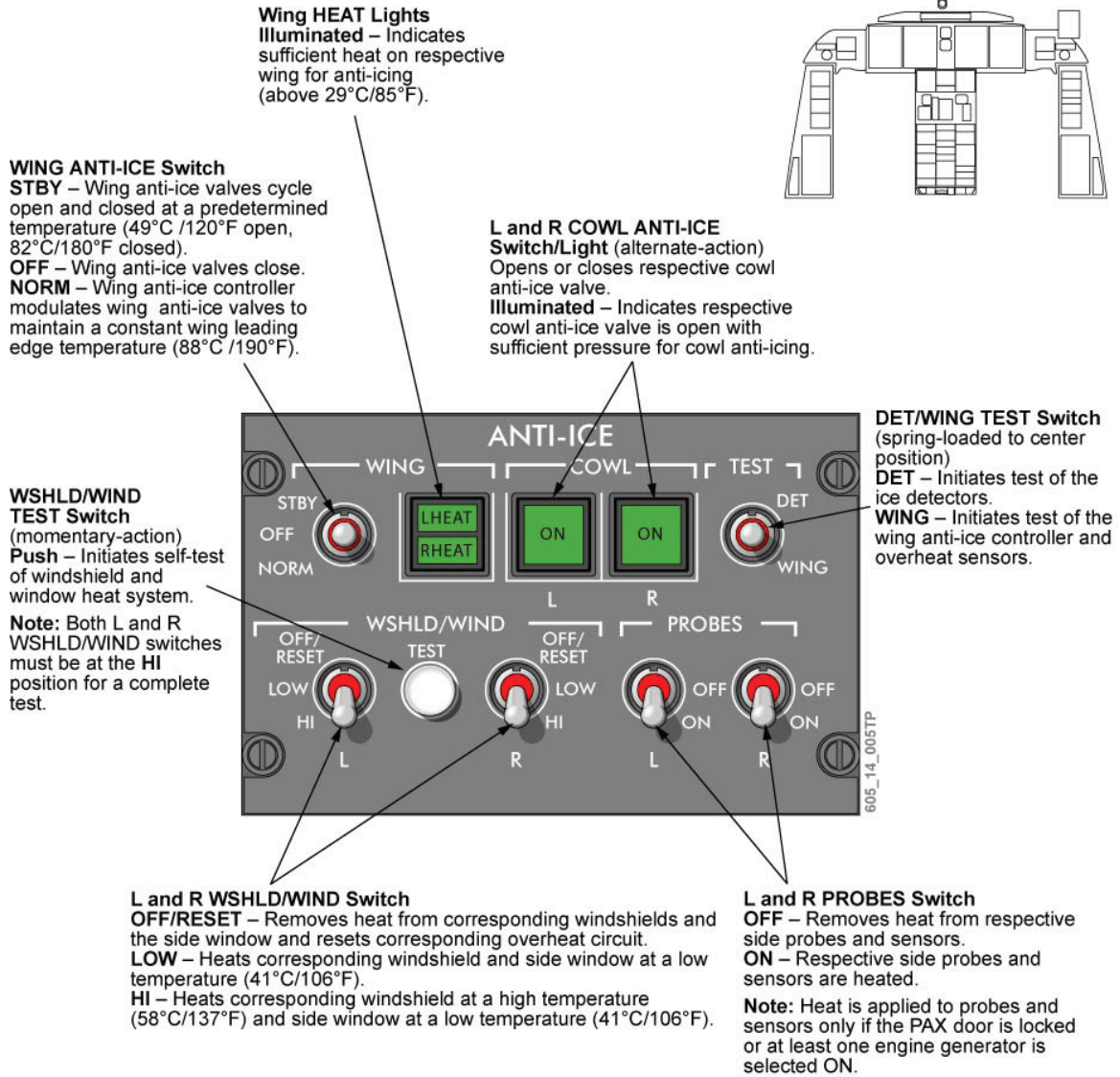

ANTI-ICE Panel
Figure 14-10-7

Bombardier Challenger 605 - Ice & Rain Protection

EICAS MESSAGES

EICAS Messages – Wing Anti-Ice System

MESSAGE	MEANING	AURAL WARNING (IF ANY)
ANTI-ICE DUCT	Bleed air leak detected in left and/or right fuselage or wing anti-ice ducts.	“ANTI-ICE DUCT”
WING OVHT	Overheat condition detected in left and/or right wing leading edge.	“WING OVERHEAT”
L WING A/ICE R WING A/ICE	With wing anti-ice selected on, insufficient pressure and temperature in respective wing leading edge for anti-icing.	
WING A/ICE SNSR	Wing anti-ice sensor failure detected (control and/or overheat sensor).	
WING A/ICE ON	Wing anti-ice is selected on with sufficient heat and pressure available for anti-icing.	
WING/COWL A/ICE ON	Wing and cowl anti-ice selected on and sufficient heat/pressure available for anti-icing.	
WING A/ICE OK	Successful test of the wing anti-ice system.	

EICAS Messages – Engine Cowl Anti-Ice System

MESSAGE	MEANING
L COWL A/ICE R COWL A/ICE	Cowl anti-ice valve failure: <ul style="list-style-type: none"> • With the cowl anti-ice selected on, respective cowl has insufficient pressure for anti-icing, or • With the cowl anti-ice selected off, respective cowl senses pressure (i.e. valve failed open).
COWL A/ICE ON	Both cowl anti-ice switches selected on and both cowls have sufficient pressure for anti-icing.
L COWL A/ICE ON	Left cowl anti-ice switch selected on and left cowl has sufficient pressure for anti-icing.
R COWL A/ICE ON	Right cowl anti-ice switch selected on and right cowl has sufficient pressure for anti-icing.

EICAS Messages – Windshield/Window Anti-Ice System

MESSAGE	MEANING
L WINDOW HEAT R WINDOW HEAT	Respective side window heat has failed or switch selected to OFF.
L WSHLD HEAT R WSHLD HEAT	Respective front windshield heat has failed or switch selected to OFF.
L WINDOW HEAT OK R WINDOW HEAT OK	Respective side window heat system has passed self-test.
L WSHLD HEAT OK R WSHLD HEAT OK	Respective front windshield heat system has passed self-test.

Bombardier Challenger 605 - Ice & Rain Protection

EICAS MESSAGES (CONT'D)

EICAS Messages – Air Data Probes and Sensors Anti-Icing

MESSAGE	MEANING
L AOA HEAT R AOA HEAT	Respective AOA heater has failed.
AUX AOA CASE HEAT	AUX AOA vane base heater has failed.
AUX AOA VANE HEAT	AUX AOA vane heater has failed.
L PITOT BASE HEAT R PITOT BASE HEAT	Respective pitot-static base heater has failed.
L PITOT TUBE HEAT R PITOT TUBE HEAT	Respective pitot-static heater has failed.
L PROBE HEAT OFF R PROBE HEAT OFF	On the ground, either all respective side anti-ice heaters have failed or the respective PROBES switch is selected off.
L STATIC HEAT R STATIC HEAT	Respective static port heater has failed.
STBY PITOT HEAT	Standby pitot probe heater has failed.
TAT PROBE HEAT	TAT probe heater has failed.

EICAS Messages – Ice Detection System

MESSAGE	MEANING
ICE	Ice has been detected and wing and/or cowl anti-ice systems are not selected on.
ICE DETECTORS	Both ice detector channels have failed.
ICE	Icing has been detected and both wing and cowl anti-ice systems are on and sufficient heat/pressure is available for anti-icing.
ICE DETECTOR 1 FAIL	Ice detector 1 has failed.
ICE DETECTOR 2 FAIL	Ice detector 2 has failed.

Bombardier Challenger 605 - Ice & Rain Protection

POWER SUPPLY AND CIRCUIT BREAKER SUMMARY

SYSTEM	SUB-SYSTEM	CB NAME	BUS BAR	CB PANEL	CB LOCATION	NOTES
Windshield/Window Anti-Ice	Windshields	HEATER L WSHLD	AC BUS 1	1	A10-11	
		HTR CONT L WSHLD	DC BUS 1	1	F14	
		HEATER R WSHLD	AC BUS 2	2	A10-11	
		HTR CONT R WSHLD	DC BUS 2	2	F14	
	Side Windows	HEATER L WIND	AC ESS	3	B3	
		HTR CONT L WIND	DC ESS	4	B13	
		HEATER R WIND	AC BUS 2	2	A12	
		HTR CONT R WIND	DC BUS 2	2	F15	
Wing and Cowl Anti-Ice	Ice Detectors	ICE DET 1	AC ESS	3	C8	
		ICE DET 2	AC BUS 2	2	B12	
	Anti-Ice Controllers	A/ICE MAN 1	DC ESS	4	B10	
		A/ICE MAN 2	DC BATT	2	N10	
		A/ICE AUTO 1	DC BUS 1	1	F10	
		A/ICE AUTO 2	DC BUS 2	2	F10	
	Anti-Ice Valves	A/ICE VALVE L ENG	DC BATT	2	N8	
		A/ICE VALVE R ENG	DC BATT	2	N9	
Probe Heaters	Pitot	HEATERS L PITOT	AC ESS	3	B4	
		HEATERS R PITOT	AC BUS 2	2	A14	
		HEATERS PITOT STBY	AC ESS	3	B6	
	Static	HEATERS L STATIC	AC ESS	3	B7	
		HEATERS R STATIC	AC BUS 2	2	A15	
	AOA	HEATERS L AOA	AC ESS	3	B5	
		HEATERS R AOA	AC BUS 2	2	A13	
		HEATERS AUX AOA	AC BUS 1	1	A13	
	TAT	HEATERS TAT	AC BUS 1	1	A12	
	ADS Controller	ADS HTR L CONT	DC ESS	4	A11	
		ADS HTR R CONT	DC BUS 2	2	G11	

Bombardier Challenger 605 - Ice & Rain Protection

POWER SUPPLY AND CIRCUIT BREAKER SUMMARY (CONT'D)

SYSTEM	SUB-SYSTEM	CB NAME	BUS BAR	CB PANEL	CB LOCATION	NOTES
Water Heaters	Supply, Storage and Drains	WATER HTRS TANK	AC UTILITY BUS 2	2	D5	
		WATER HTRS LINE	AC UTILITY BUS 2	2	D6	
		WATER HTRS GALLEY	AC UTILITY BUS 2	2	D7	
		WATER HTRS LAV	AC UTILITY BUS 2	2	D8	