

**Table of Contents**

Introduction .....	13-01-01
Left and Right Hydraulic System .....	13-01-01
Description .....	13-01-02
Components and Operation .....	13-01-03
Engine-Driven Pumps .....	13-01-03
DC Motor-Driven Pump .....	13-01-03
Hydraulic Shutoff Valve .....	13-01-03
Hydraulic Reservoir .....	13-01-03
Ecology Bottle .....	13-01-04
Unloading of Hydraulic Pump for Inflight Restarts .....	13-01-04
Left and Right Hydraulic System Cooling .....	13-01-04
Hydraulic Reservoir Quantity Percentages .....	13-01-04
Left Hydraulic System Schematic .....	13-01-05
Right Hydraulic System Schematic .....	13-01-06
Auxiliary Hydraulic System .....	13-01-07
Description .....	13-01-07
Components and Operation .....	13-01-07
Auxiliary DC Motor-Driven Pump .....	13-01-07
Auxiliary Hydraulic System Accumulators and Reservoir .....	13-01-07
Auxiliary System Switching Valve .....	13-01-07
Auxiliary System Pressure Filter .....	13-01-07
Power Transfer Unit .....	13-01-08
Description .....	13-01-08
Components and Operation .....	13-01-08
Hydraulic Servicing .....	13-01-08
Description .....	13-01-08
Hydraulic Servicing Panel .....	13-01-09
Auxiliary Accumulator Servicing .....	13-01-10
Auxiliary Hydraulic System Schematic .....	13-01-11
Controls and Indications .....	13-01-12
Description .....	13-01-12
Hydraulic Control Panel .....	13-01-12
Hydraulic Synoptic Page .....	13-01-13
EICAS Messages .....	13-01-14



**INTRODUCTION**

The Challenger 300 has a left and right hydraulic system that are independent from each other, and an auxiliary system that is tied to the right hydraulic system. The left, right, and auxiliary systems are controlled from the HYDRAULICS panel, located immediately to the right of the throttle quadrant on the center pedestal. The hydraulic systems normally operate at 3000 psi and use Fire Resistant Phosphate Ester based MIL-H-5440 Type II fluid. The left and right hydraulic systems are both powered by Engine-Driven Pumps (EDPs) which are backed up by a DC Motor-driven Pumps (DCMPs). The left and right hydraulic systems DCMPs are powered by the electrical DC bus supplied by the generator on the engine opposite the engine which drives the EDP. Thus, hydraulic power is provided for the left and right systems after any single engine failure. After the loss of the left and right hydraulic systems, the lower rudder PCU will be powered by the AUX hydraulic system.

The L DCMP is powered by the R MAIN DC bus. There is no battery backup for the R MAIN DC bus. If the right DC generator fails, the R MAIN DC bus can be powered by the L DC generator or the APU.

The R DCMP is powered by the L ESS bus. The bus can be powered by the right dc generator or the APU if the left DC generator fails. If no generators are operational, the R DCMP will only automatically start if the pilot selects the flaps to a non-zero position. If only one generator is operational on the airplane, then only one of the L or R DCMPs is operational, (one DCMP is load shed from the good hydraulic system with the R DCMP taking priority over the left DCMP if both EDPs are failed). AUX DCMP is not load shed for single generator operation.

The AUX DCMP is powered by the L ESS bus. There is battery backup for this bus, but the battery size is limited and only powers this DCMP for the last few minutes of flight. The L ESS bus can be powered by the R DC generator or the APU if the L DC generator fails.

In case of total generator failure, the pilot can select the AUX DCMP off until just prior to landing to conserve battery power. The elevators will be in manual reversion, and the rudder will also be in manual reversion if the auxiliary hydraulic system fails. In addition, roll assist with roll spoilers will be lost. The ailerons are strictly manually controlled through cables and pulleys. Due to the loss of flaps, thrust reversers, and lift dumping devices, the aircraft landing distances will be significantly increased.

**LEFT AND RIGHT HYDRAULIC SYSTEM**

**DESCRIPTION**

The major components of the left and right hydraulic system are: Engine-Driven Pumps (EDPs), DC Motor Pumps (DC-MPs), Firewall Shutoff Valves (SOVs), control valves, fluid reservoirs, and sensors for monitoring and control for each system. The left and right hydraulic systems each have separate fuel/hydraulic fluid heat exchangers in their respective wing fuel tank. With the exception of the EDPs, and heat exchangers, the major components are located in the aft equipment compartment. The EDPs are mounted on the engine accessory gearboxes.

LEFT HYDRAULIC SYSTEM:	RIGHT HYDRAULIC SYSTEM:	AUX HYDRAULIC SYSTEM:
Multi-functional spoilers (inboard)	Multi-functional spoilers (outboard)	Lower Rudder PCU
Ground spoilers (inboard)	Ground spoilers (outboard)	
Rudder (upper PCU)	Rudder (lower PCU)	
Left thrust reverser	Right thrust reverser	
Inboard brakes, emergency	Outboard brakes	
Nose wheel steering actuator	Main landing gear assist actuators	
Elevator (inboard PCUs)	Elevator (outboard PCUs)	
Alternate FLAPS	Normal FLAPS supply	
Landing Gear	Power transfer unit	

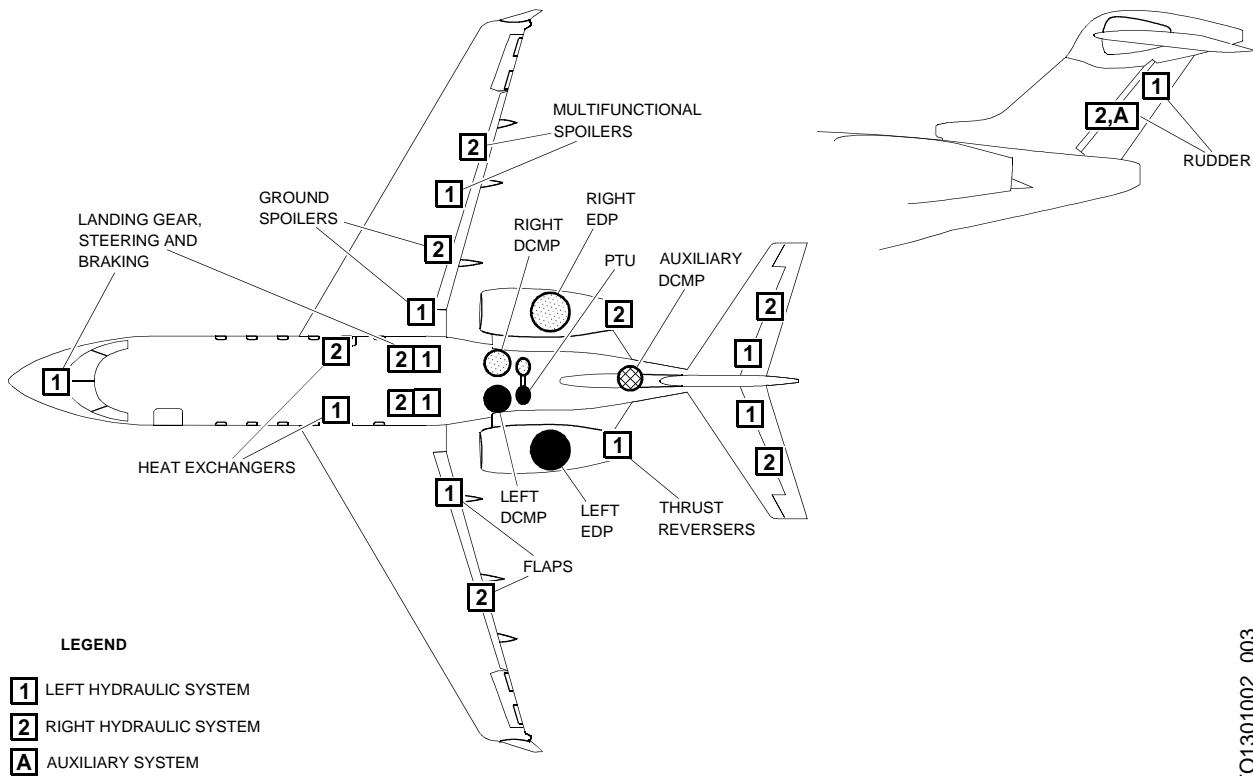

CFO1301002\_003

## **LEFT AND RIGHT HYDRAULIC SYSTEM (Cont)**

### **COMPONENTS AND OPERATION**

#### **ENGINE-DRIVEN PUMPS**

The left and right hydraulic systems are each powered by an Engine Driven Pump (EDP). It is flange-mounted to the engine gearbox and driven through a splined input shaft. The pumps are a variable-delivery, piston type, that maintain a nominal system pressure of 3000 psi. The EDPs operate any time the engines are turning. Pressure switches located in the pump outflow lines provide low-pressure indications to the flight crew. The discharge, suction and case drains ports of the pump include quick-disconnect fittings and are connected directly to the aircraft systems through hoses. The case drain port is located on the top side of the pump near the mounting flange for maximum case drain cooling of pump components. This location also assures bleeding of air after installation of a new pump. The pump incorporates a solenoid isolation/actuation valve to reduce discharge pressure and torque when energized. During an engine windmill restart, the solenoid will be activated by the FADEC to depressurize the pump. The left EDP flow and left DCMP flow combines in the left filter manifold. The right EDP flow and right DCMP flow combines in the right filter manifold. The hydraulic fluid is never mixed between the left and right systems.

#### **DC MOTOR-DRIVEN PUMP**

The left and right hydraulic systems each have one DC Motor-driven Pump (DCMP). The primary purpose of the DCMPs is to pressurize the hydraulic systems during an engine or EDP failure. The DCMP serves also the ground maintenance operation purposes. The DCMP contains a DC electric motor which is attached to a variable-delivery hydraulic pump. The DC motor operates the pump, which can change the volume of fluid flow to maintain the necessary system pressure. The left and right hydraulic system DCMPs are installed on their respective side of the aft equipment compartment.

Electrical power is supplied by the DC bus through an electrical connector on the DCMP. The generator of the right engine supplies power to the left DCMP. The generator of the left engine supplies power to the right DCMP.

The left and right DCMPs are each controlled by a three-position switch. The switch positions are OFF, AUTO, and ON. The OFF and ON allow manual operation. The AUTO position is the normal position for flight. In this position, the DCMPs will be off with flaps up, and on with flaps set at 10° or greater. In addition, if low hydraulic system pressure is detected, the DCMP will automatically turn on.

#### **HYDRAULIC SHUTOFF VALVE**

Each of the left and right hydraulic systems contain a firewall shutoff valve (SOV) placed in the EDP suction line outside of the pylon area. In the case of engine fire, this valve can be closed to stop hydraulic fluid from reaching the engine area. Both SOVs are located inside the aft equipment compartment forward of the hatch opening. The valves are normally in the open position, however, pressing the L (R) SOV push button on the HYDRAULIC control panel or the L (R) ENG FIRE push button on the ENGINE control panel closes the corresponding hydraulic shutoff valve. Control logic also closes the valve automatically when the system fluid temperature exceeds 275 °F. When a firewall SOV is operated, the DCMPs are the only hydraulic pressure source available for the left or right hydraulic systems.

#### **HYDRAULIC RESERVOIR**

Each of the hydraulic systems contains a reservoir for the storage of hydraulic fluid. The reservoir provides the necessary fluid volume demanded by the hydraulic system, including pressurization of the pump inlet. Changes in the fluid volume due to thermal expansion/contraction, system leakage and differential area of the user actuators have been taken into account in sizing and volume of each reservoir. The left and right hydraulic system reservoirs are installed on their respective sides in the aft equipment compartment. The fluid volume of the left hydraulic reservoir is 13 quarts (12.3 liters). The fluid volume of the right hydraulic reservoir is 9.1 quarts (8.6 liters). Each reservoir has a bleed/relief valve, visual quantity indicator, suction shutoff valve, and ports for installation of the temperature switch and temperature transducer. There is also a check valve installed in the fluid return port.

The bleed valve is accessible to maintenance personnel and is manually opened by depressing a lever. When released, the lever automatically returns to the closed position. The location of the valve at the high point of the reservoir, as well as the routing of the internal porting to the valve, assures that air in the fluid will migrate to the outlet and be released when the valve is opened. Flow from the valve is routed to the ecology bottle.

**LEFT AND RIGHT HYDRAULIC SYSTEM (Cont)**

The visual quantity indicator is a gauge that shows the hydraulic fluid level in the reservoir. The gauge has marks from zero to 100% in increments of 10%. The indicator senses the position of the low-pressure piston as a measure of the remaining fluid volume. The quantity indicator also sends an electrical output signal to the Remote Data Concentrator (RDC), which shows fluid quantity on the hydraulic synoptic page, and on the copilot's MFD hydraulic summary page.

The suction shutoff valve is installed in the pump suction port of the reservoir. This shutoff valve is closed by the reservoir piston when the fluid level is almost empty. This prevents fuel from being pumped into the hydraulic system if there is a break in a hydraulic line inside the fuel tank.

**ECOLOGY BOTTLE**

The left and right hydraulic systems each contain an ecology bottle installed in the lower part of the rear fuselage. The ecology bottles collect hydraulic fluid leakage from the DCMP shaft seals, PTU seal drain port, and the reservoir bleed/relief valves. The bottles are transparent in order to see the level of the hydraulic fluid inside.

**UNLOADING OF HYDRAULIC PUMP FOR INFLIGHT AIRSTARTS**

The engine driven pump incorporates a depressurization circuit to unload the pump and reduce the input torque required during engine relights. Also when the reservoir fluid temperature reaches 275 °F, the PSEU will command the FADEC to depressurize the engine driven pump. The DCMP will also automatically continue providing hydraulic pressure to other systems after the EDP stops functioning. No action is required of the flight crew, as the above procedures are automatic.

**LEFT AND RIGHT HYDRAULIC SYSTEM COOLING**

The left and right hydraulic systems require cooling due to heat generated by the EDPs and other heat sources within the engine nacelle. The left and right hydraulic systems have a fuel/hydraulic heat exchanger in each wing tank.

A thermostatically controlled bypass valve is installed between the heat exchanger inlet and outlet line on each hydraulic system. The valve controls the flow of pump case drain fluid to the heat exchanger as a function of fluid temperature. It also acts as a thermal bypass valve if pressure drop through the heat exchanger becomes excessive.

At fluid temperatures above 125 °F the valve is in the full open mode and routes all incoming fluid through the heat exchanger to provide cooling. Below 125 °F the valve is in the bypass mode and routes all incoming fluid around the heat exchanger and directly to the reservoir. If 275 °F is detected for more than 3 seconds, the SOV will close and a L (R) HYD TEMP HIGH (C) CAS message will be illuminated.

**HYDRAULIC RESERVOIR QUANTITY PERCENTAGES**

The hydraulic reservoir quantity percentages are displayed in 2% increments on the Summary page and Hydraulic Synoptic page. When the quantity levels are within normal range (as shown in the table below), the quantity percentages will be displayed in green. When the hydraulic systems levels are above or below normal, the percentages will be displayed in white. Approximately 25% of the fluid is in the landing gear hydraulic lines and actuators when the gear is down, so quantity percentages will show lower but usually stay in the normal range. When the gear is retracted, the fluid level percentages will climb but still stay in the normal range. If the system percentage is less than the normal lower level, it will display the percentage in white and it should be serviced prior to flight. If the left system has been over serviced, it may port excess fluid through the left system reservoir relief valve when the landing gear is retracted. There are no CAS messages associated with percentages that are above or below normal levels.

	<b>LEFT SYSTEM</b>	<b>RIGHT SYSTEM</b>	<b>AUXILIARY SYSTEM</b>
<b>NORMAL UPPER LEVEL PERCENTAGES</b>	85%	85%	85%
<b>NORMAL LOWER LEVEL PERCENTAGES</b>	30%	40%	20%

LEFT AND RIGHT HYDRAULIC SYSTEM (Cont)

LEFT HYDRAULIC SYSTEM SCHEMATIC

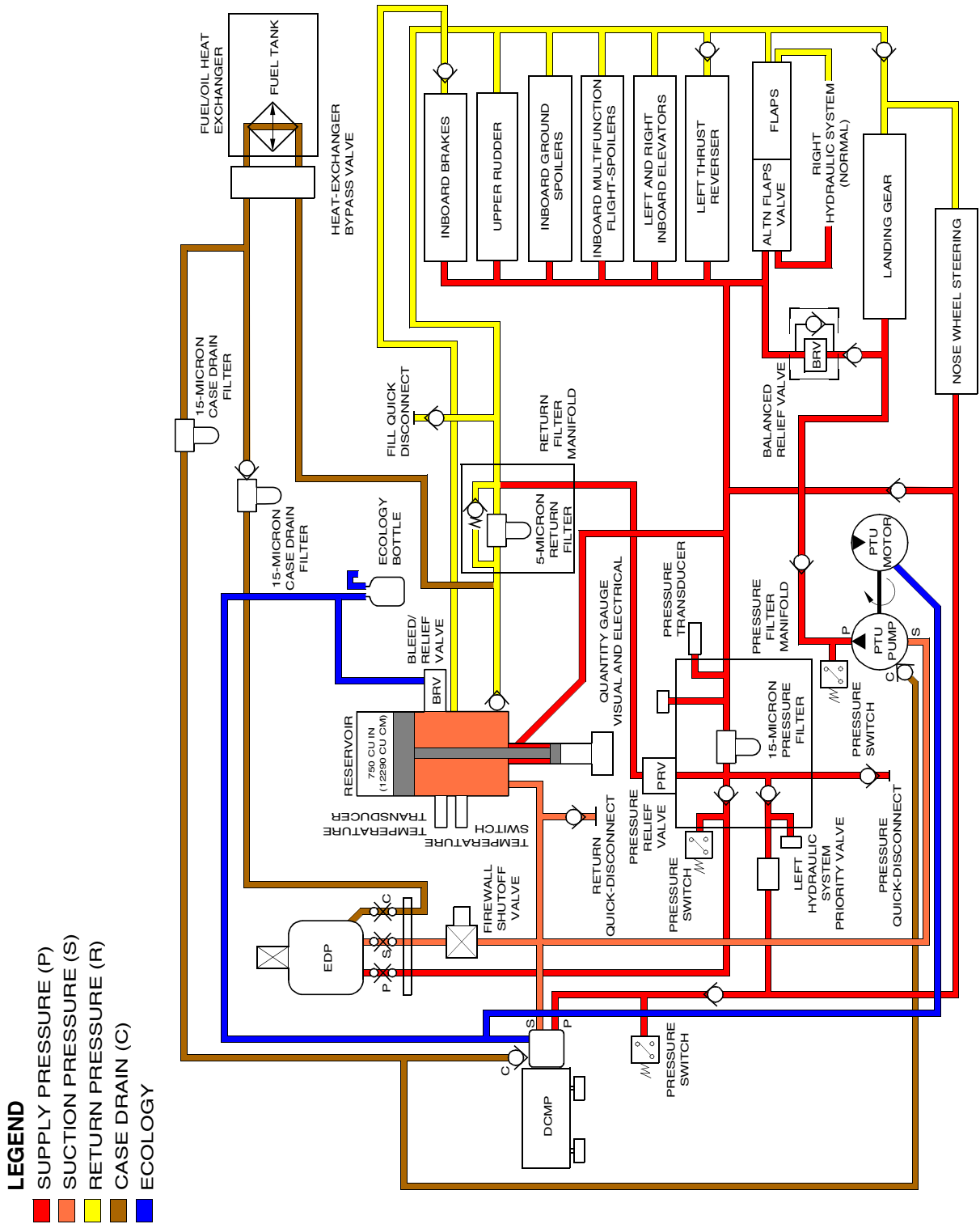

LEFT AND RIGHT HYDRAULIC SYSTEM (Cont)

RIGHT HYDRAULIC SYSTEM SCHEMATIC

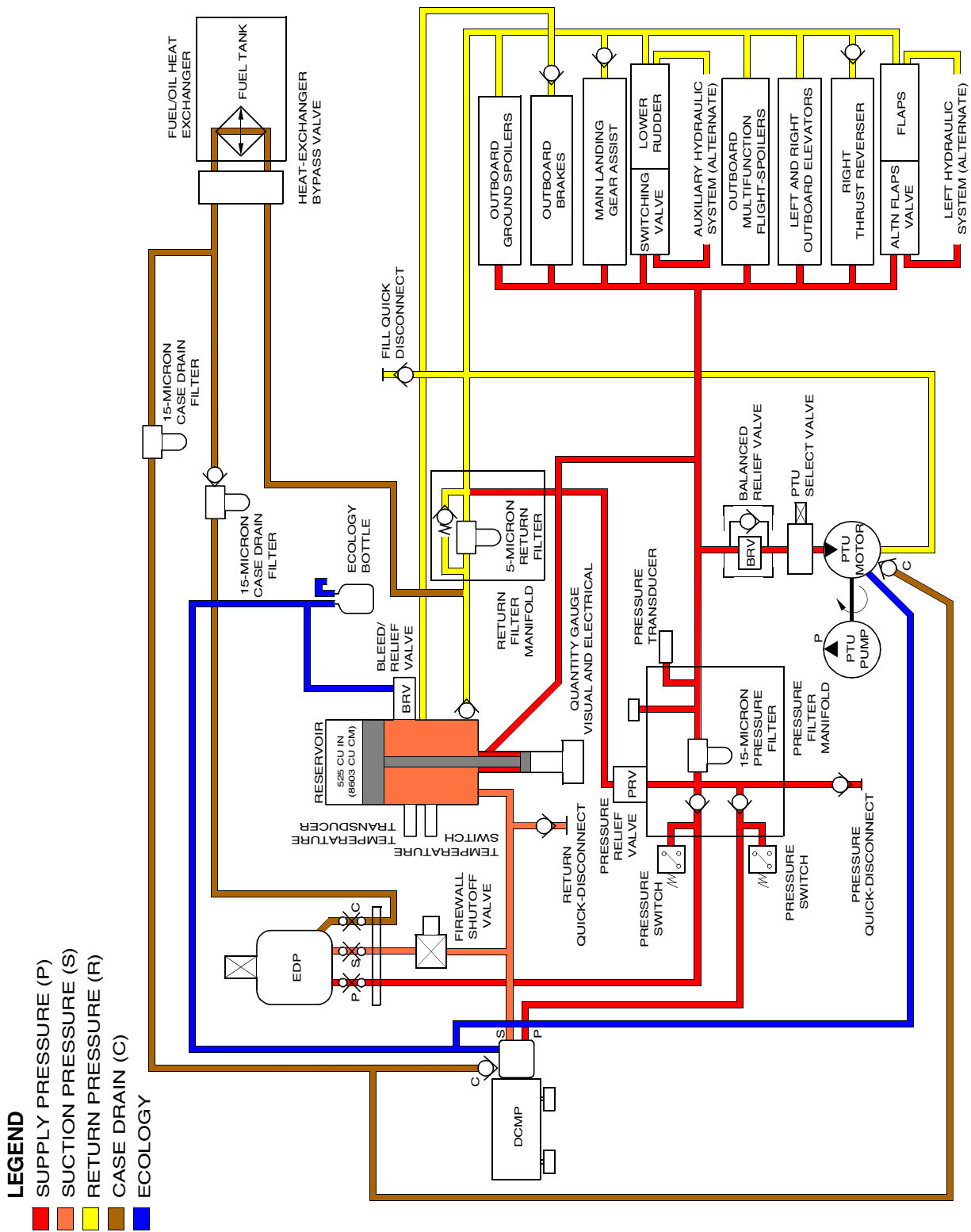



## **AUXILIARY HYDRAULIC SYSTEM**

### **DESCRIPTION**

The purpose of the auxiliary hydraulic system is to provide hydraulic pressure to the lower rudder PCU as a result of the right hydraulic system failure. The auxiliary hydraulic system includes a DCMP, a reservoir, and an accumulator, all located aft of the engine rotor burst zone. The right hydraulic system normally powers the lower rudder PCU. During a loss of right system pressure, a hydraulic switching valve allows the auxiliary system to provide pressure to the lower rudder PCU. The left or right hydraulic system may be activated without the system already being pressurized. However, the auxiliary system has an intensifier pressurized by the right hydraulic system. During the preflight check, select R PUMP ON before selecting AUX PUMP to AUTO to prevent cavitation.

The auxiliary hydraulic system pressure is generated by a constant displacement DCMP. The pump is controlled by a two position AUX PUMP switch. The OFF position disables the pump. In the AUTO position, a pressure switch allows the pump to activate as needed.

### **COMPONENTS AND OPERATION**

#### **AUXILIARY DC MOTOR-DRIVEN PUMP**

The auxiliary DCMP function is to maintain fluid pressure on the auxiliary system accumulator. When the system pressure decreases to 2500 psi, an external pressure switch turns on the pump until pressure has reached 3350 psi. At that time, the pressure switch deactivates, commanding the pump off.

#### **AUXILIARY HYDRAULIC SYSTEM ACCUMULATORS AND RESERVOIR**

The auxiliary system accumulator has a nominal gas volume for 50 cubic inches of dry nitrogen, to satisfy the instantaneous demands of the hydraulic pressure and dampen out pressure surges with in the system. The pre-charge pressure versus temperature is set so that when the accumulator is discharged, the accumulator will still have sufficient oil for a smooth continuous operation of the lower rudder as the pump comes on line at approximately 2500 psi.

The auxiliary system uses an intensifier to augment the inlet pressure to the auxiliary DCMP to prevent pump cavitation. The intensifier is a simple spring-loaded piston that transmits pressure from the RH system to the pressure side of the auxiliary system reservoir. The DC pumps will come on prior to the engines starting and supply the intensifier with pressure. The AUX DCMP will come on if the AUX DCMP is selected to AUTO, there is power to the aircraft, and the aux system accumulator pressure is low. Once the AUX DCMP pressurizes, it is self-priming and its operation is independent of the RH system.

#### **AUXILIARY SYSTEM SWITCHING VALVE**

The function of the auxiliary system switching valve is to transmit right hand system pressure to the lower rudder PCU under normal operating conditions. With loss of RH hydraulic system pressure, the switching valve shuttles and applies Auxiliary System pressure to the lower rudder PCU. The valve shuttles strictly in accordance with the RH System pressure and does not rely on any software or electrical interface to function.

#### **AUXILIARY SYSTEM PRESSURE FILTER**

The aux system contains a pressure filter. This assembly filters the supply pressure fluid coming in from the DCMP. It is made up of a filter element and a bowl, a differential pressure indicator, and an automatic shutoff device. The filter is a non-bypassing design. The flow through the assembly is blocked when the bowl is removed. A filter element is provided which removes 100% of all contaminants larger than 15 microns and is a non-cleanable type. The auxiliary system pressure filter and the case drain filter element used on the filter manifolds of the left and right systems are identical, and interchangeable.

## **POWER TRANSFER UNIT**

### **DESCRIPTION**

The Power Transfer Unit (PTU) consists of a hydraulic motor coupled mechanically through a drive shaft to a hydraulic pump. When the PTU selector valve is energized, the hydraulic motor is driven by pressure from the right hydraulic system. The pump side of the PTU is connected to the left system and is dedicated to operation of the landing gear. The PTU also provides pressurization for the left hydraulic system reservoir.

When the PTU selector valve is energized, the hydraulic motor is driven by pressure from the right hydraulic system. The PTU is connected to the left hydraulic system and is dedicated to retracting and extending the landing gear. The PTU is used for gear operation when the left EDP system or left engine is not operational. Should the left engine fail during takeoff, gear retraction time will be excessively slow using the DCMP, however, with the PTU engaged gear retraction time will be normal. A priority valve is placed upstream of the PTU to protect the right system pressure from being pulled down to unacceptable levels due to excessive flow demand from the PTU.

### **COMPONENTS AND OPERATION**

The PTU is controlled by a three-position switch. The switch positions are OFF, AUTO, and ON. In the OFF and ON positions, the PTU valve is manually closed or open.

In the AUTO mode:

- the PTU will only start when the left engine or the left EDP is inoperative or failed
- the right EDP is producing pressure
- the gear is not in its commanded position
- and the aircraft is in the air.

The PTU will allow the gear to operate at its normal rate with only a slight increase in transit time due to delays associated with the PTU solenoid being commanded on, solenoid energizing, and the PTU coming up to speed.

If the PTU, is selected to AUTO and does not produce hydraulic pressure within 15 seconds, it will be latched OFF to minimize the load placed on the right hydraulic system. The latch will only be reset if AUTO mode is de-selected by the cockpit crew or power is removed from the Proximity Sensor Electronics Unit (PSEU).

The PTU can also be manually selected ON by the cockpit crew. If only the right DCMP is operational, the landing gear may be extended using the main landing gear assist system rather than using the PTU in the left system.

## **HYDRAULIC SERVICING**

### **DESCRIPTION**

The left and right hydraulic systems each have ground service quick-disconnects for ground fill, pressure and return fluid circuits. These are used for ground maintenance tasks such as system bleeding, flushing, draining and ground pressurization. The auxiliary system filler has a quick-disconnect to add hydraulic fluid to the auxiliary reservoir. The quick disconnects are installed on panels near the system access doors.

HYDRAULIC SERVICING (Cont)

HYDRAULIC SERVICING PANEL

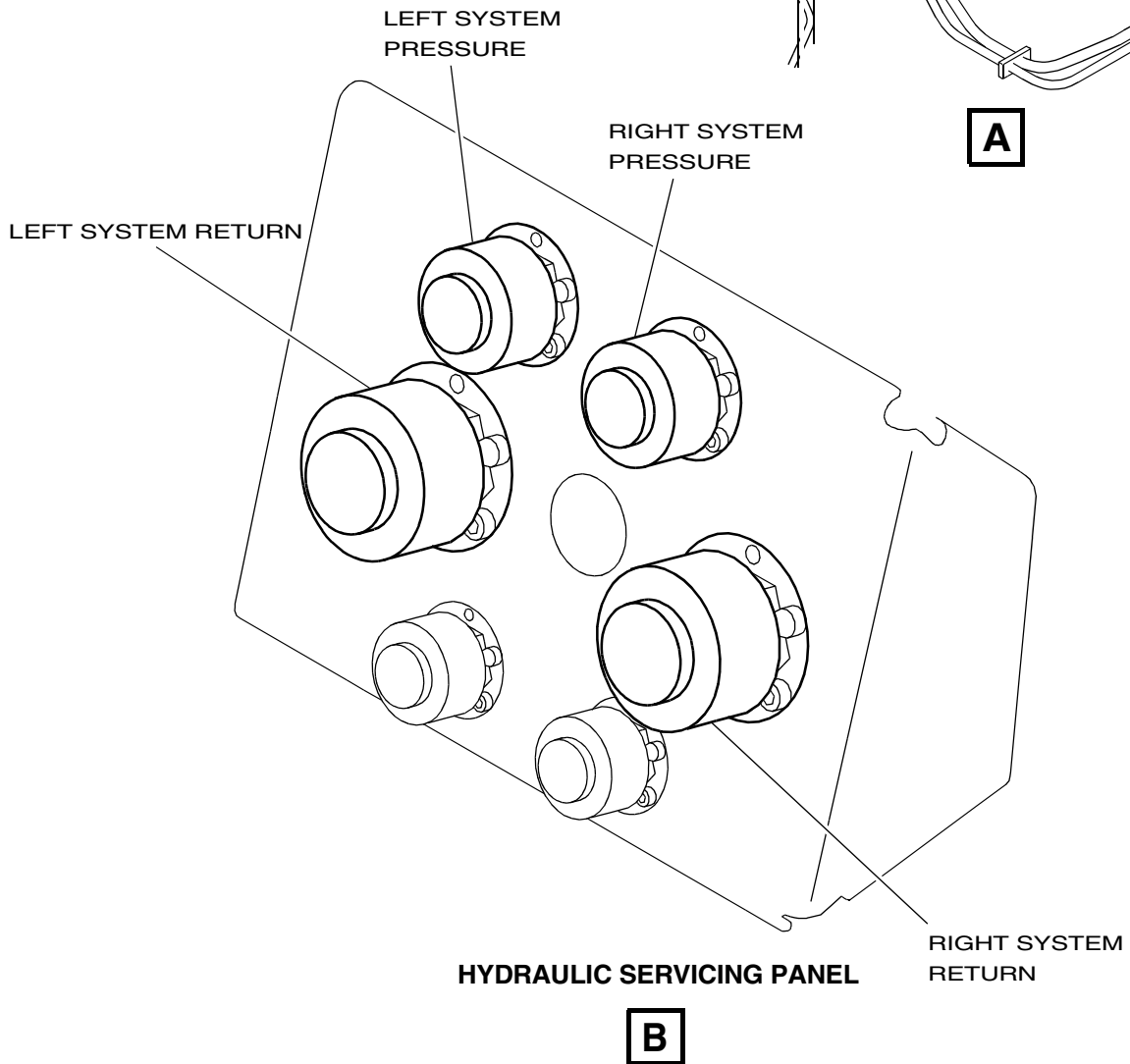
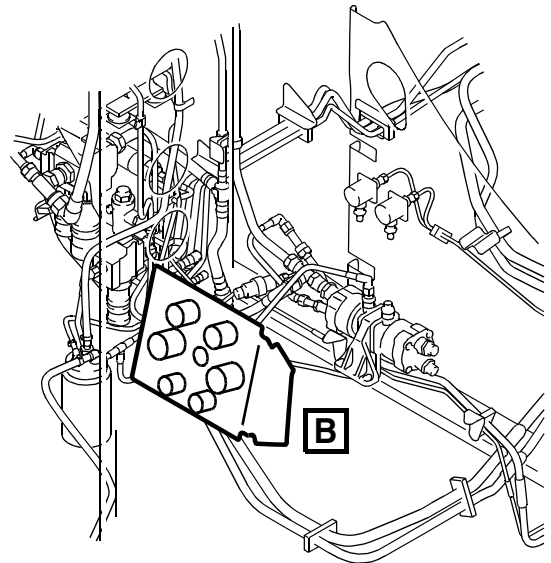
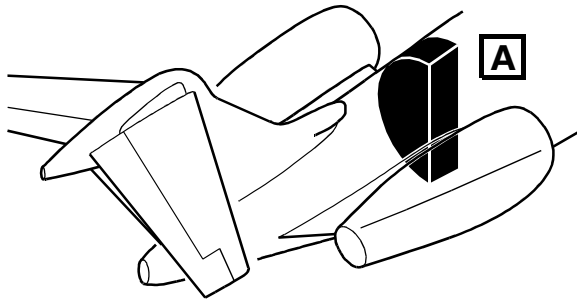

CFO1301002\_007

HYDRAULIC SERVICING (Cont)

AUXILIARY ACCUMULATOR SERVICING

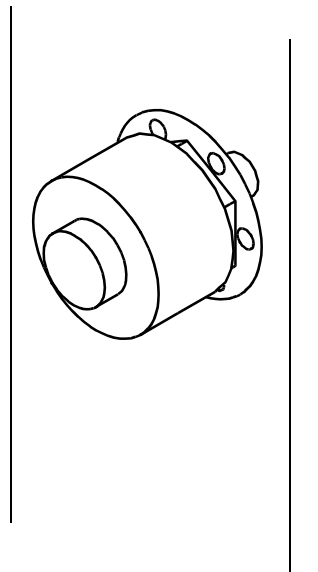
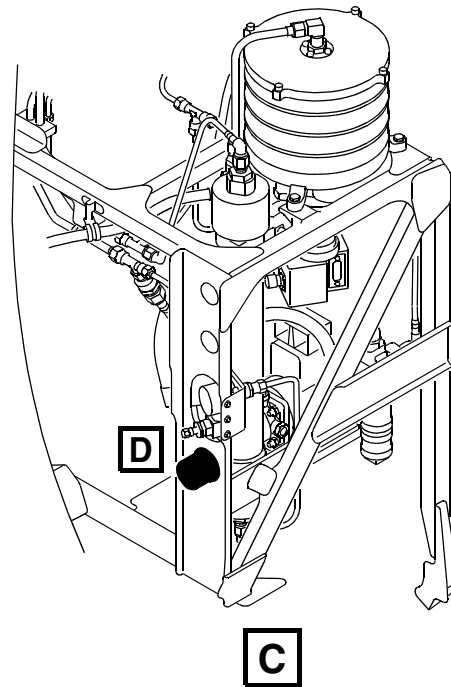
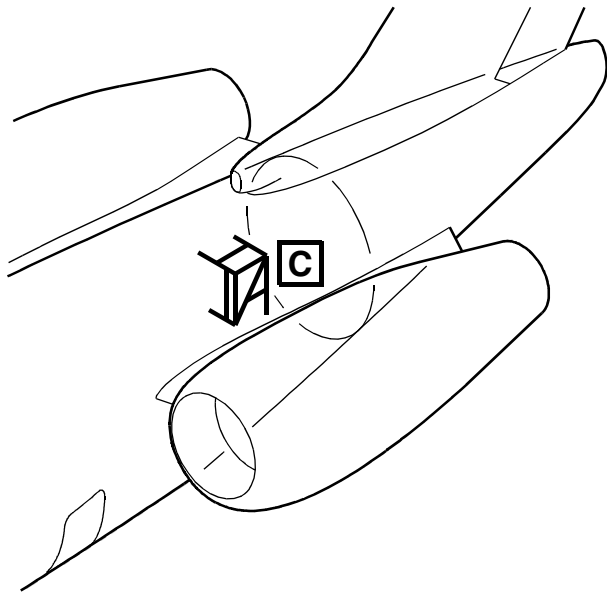

AUXILIARY ACCUMULATOR SERVICING



CFO1301002\_008

AUXILIARY HYDRAULIC SYSTEM SCHEMATIC

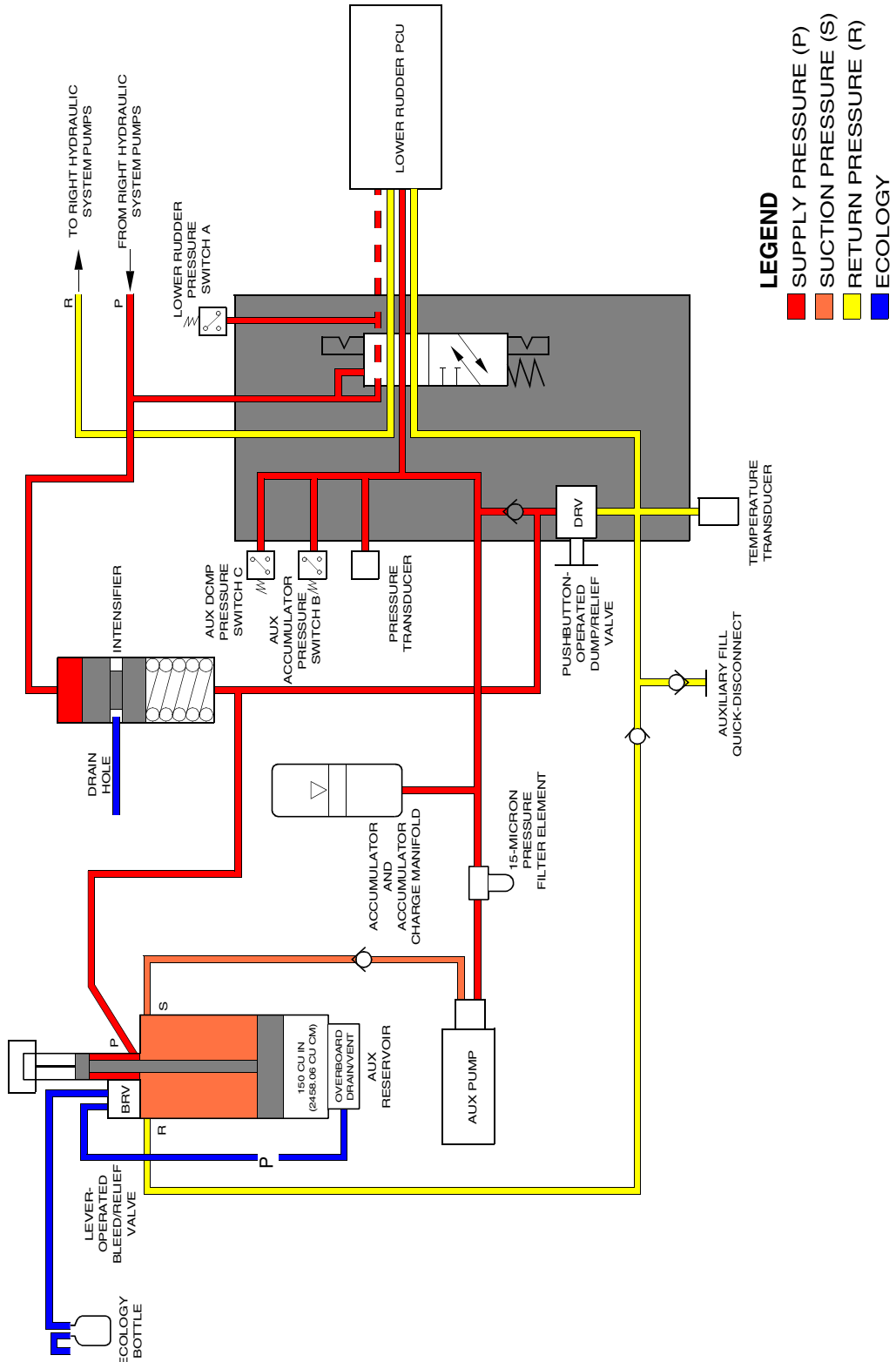

- LEGEND**
- █ SUPPLY PRESSURE (P)
  - █ SUCTION PRESSURE (S)
  - █ RETURN PRESSURE (R)
  - █ ECOLOGY

CFO1301002\_014

## CONTROLS AND INDICATIONS

### DESCRIPTION

The hydraulic control panel is located immediately to the right of the throttle quadrant on the center pedestal. From the hydraulic control panel the electric hydraulic pumps, shutoff and selector valves, and power transfer unit can be manually operated. The Engine Indicating and Crew Alerting System (EICAS) monitors and displays the hydraulic system information.

### HYDRAULIC CONTROL PANEL

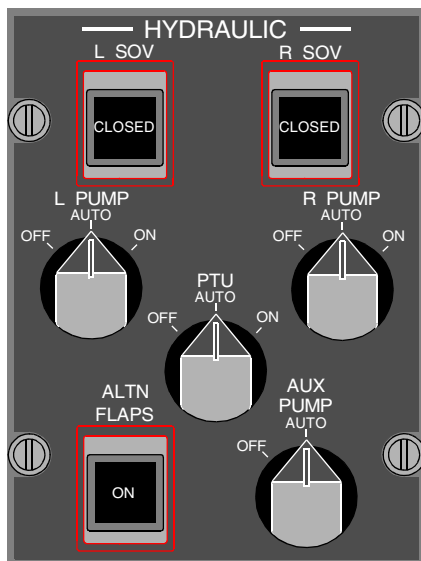

CFO1301002\_006

CONTROLS AND INDICATIONS (Cont)

HYDRAULIC SYNOPTIC PAGE

The hydraulic system operation is monitored and status displayed on the hydraulic synoptic page.

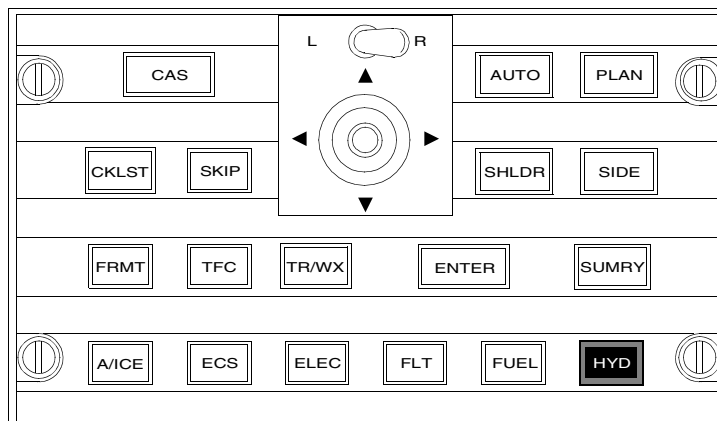
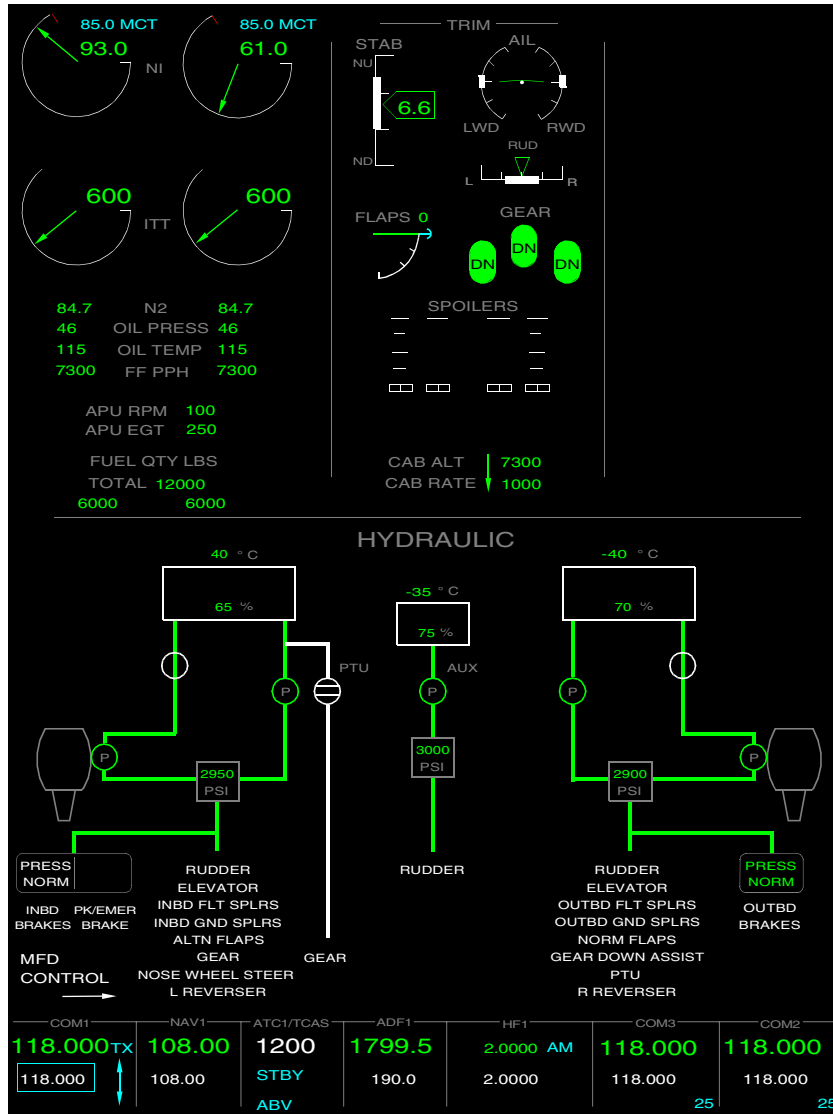

CFO0305002\_014

**EICAS MESSAGES**

The hydraulic system messages are shown on the EICAS. In the table below, the hydraulic system messages and inhibits are listed. A brief explanation of each message is provided.

<b>MESSAGE</b>	<b>INHIBITS</b>	<b>MEANING</b>	<b>AURAL WARNING</b>
<b>HYD PRESS LOW</b>		The left and right hydraulic pressures are less than 1800 psi	
<b>AUX HYD TEMP HIGH</b>	TO/LAND	The auxiliary hydraulic fluid system temperature is greater than 135 °C	
<b>L (R) HYD PRESS LOW</b>	TO/LAND	The affected hydraulic system pressure is less than 1800 psi	
<b>HYD PTU FAIL</b>	TO/LAND	The power transfer unit is not producing pressure when it should be	
<b>L (R) HYD SOV FAIL</b>	TO/LAND	The respective hydraulic shutoff valve did not close when one of the following occurred: - The respective ENG FIRE switch was pressed - The respective HYDRAULIC SOV switch was selected CLOSED - The automatic overtemp closure was commanded Or the respective hydraulic SOV is CLOSED when it should be Open	
<b>L (R) HYD TEMP HIGH</b>	TO/LAND	The respective hydraulic system temperature is above 100 °C	
<b>AUX HYD SYS FAIL</b>	TO/LAND	The auxiliary hydraulic pump is not producing pressure when it should	
<b>AUX HYD PUMP FAIL ON</b>	TO/LAND	The auxiliary hydraulic pump is running continuously	
<b>L (R) HYD DC PUMP FAIL</b>	TO/LAND	The respective hydraulic pump is not producing pressure when it should	
<b>L (R) HYD ENG PUMP FAIL</b>	TO/LAND	The respective hydraulic pump is not producing pressure when it should	
<b>HYD PUMP NOT AUTO</b>		At least one of HYDRAULIC PUMP (L,R, PTU, or AUX) switch is not in the AUTO position	
<b>L (R) HYD SOV CLOSED</b>		The respective hydraulic shutoff valve is closed	