

IR DISCREPANCY

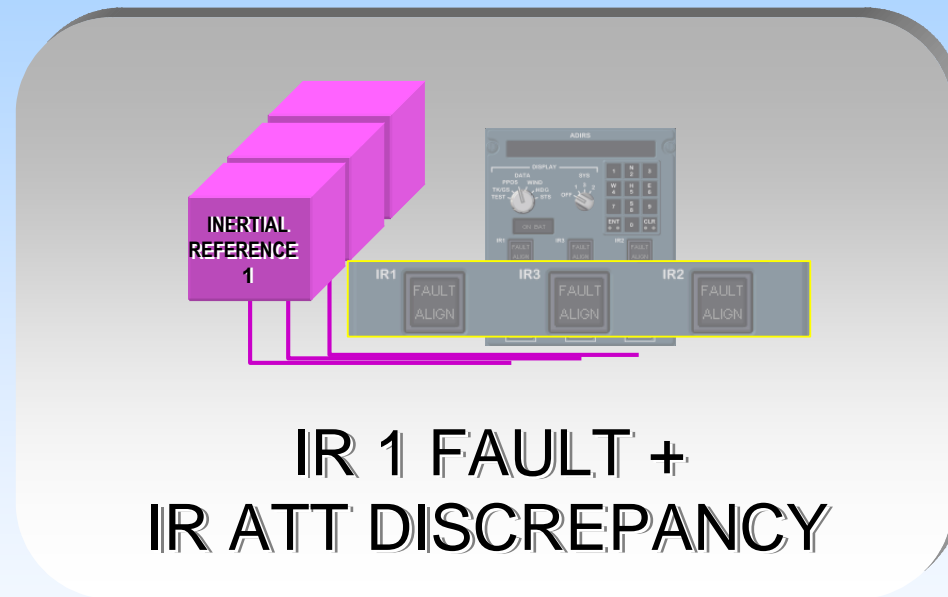

PF

PNF

1. NAV IR 1 FAULT

DETECTION

CM2 ⇒ PF

FLIES THE AIRCRAFT

NAVIGATES

CONSIDER AUTOMATION USE

ECAM ACTIONS

ECAM PROCEDURE



SYSTEM DISPLAY

STATUS

RETURN TO NORMAL TASK SHARING



PF

COMMUNICATES

PF

PNF

2. NAV ATT DISCREPANCY

DETECTION

CM2 ⇒ PF

FLIES THE AIRCRAFT ⇒ LOSS OF AP, FD A/THR



NAVIGATES ⇒ ...Short term decision

CONSIDER AUTOMATION USE

ECAM ACTIONS

ECAM PROCEDURE



SYSTEM DISPLAY

STATUS

RETURN TO NORMAL TASK SHARING

DECISION

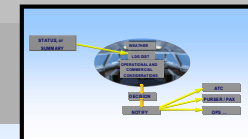

➤ IR ARCHITECTURE :



OBSERVE ECAM MEMO

ADIRS SWTG

FLIGHT IS FROZEN TO PERMIT THE PROCEDURE APPLICATION ON THE M/FTD

PF

PNF

3. APPROACH PREPARATION

FMGS.....PREPARE

APPR BRIEFINGPERFORM

Done upon PF request



FMGS PREPARATION :

STANDARD



APP BRIEFING :

STANDARD

+

STATUS

APPROACH SYNTHESIS



FLIGHT IS FROZEN TO PERMIT THE PROCEDURE APPLICATION ON THE M/FTD

THE END...

ECAM PROCEDURE

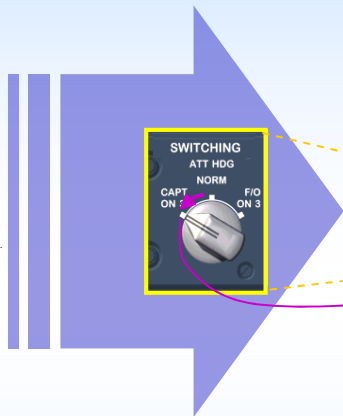
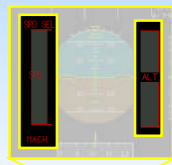

PF

PNF

2. NAV ATT DISCREPANCY

DETECTION

CM2 ⇒ PF

FLIES THE AIRCRAFT ⇒ LOSS OF AP, FD A/THR



ENG THRUST LOCKED



Single Chime
(every 5 sec)

Move the thrust levers to
the actual thrust position

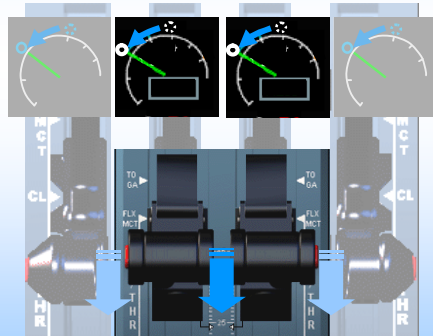

ONS
CEDURE



SPLAY

K SHARING

V

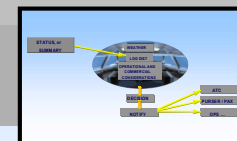

OBSERVE ECAM MEMO

ADIRS SWTG

FLIGHT IS FROZEN TO PERMIT THE PROCEDURE APPLICATION ON THE M/FTD

DE

ECAM PROCEDURE



DFE

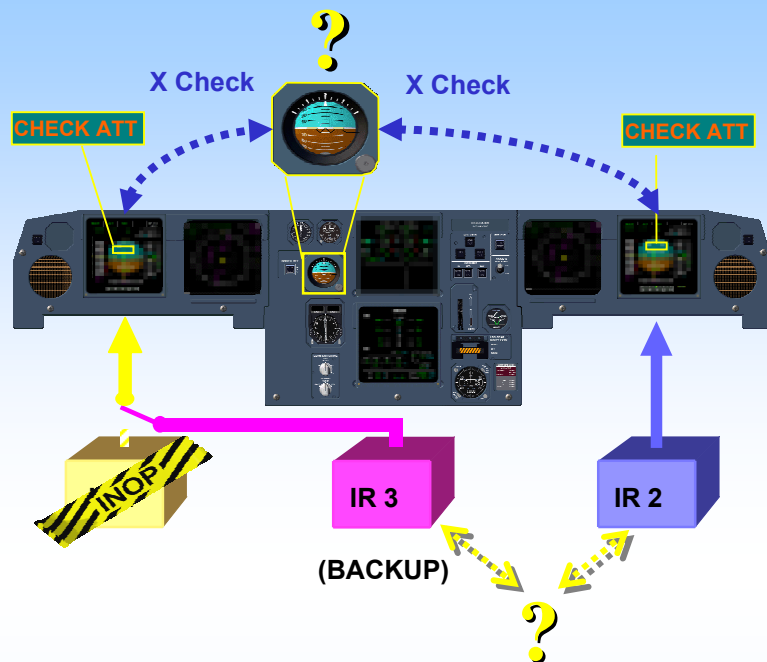

DIRECT LAW

Both pilot confirmation for this action



ALTN LAW WITH REDUCED PROTECTIONS

IR ARCHITECTURE (1/2)



(for next info, press here : ▶)

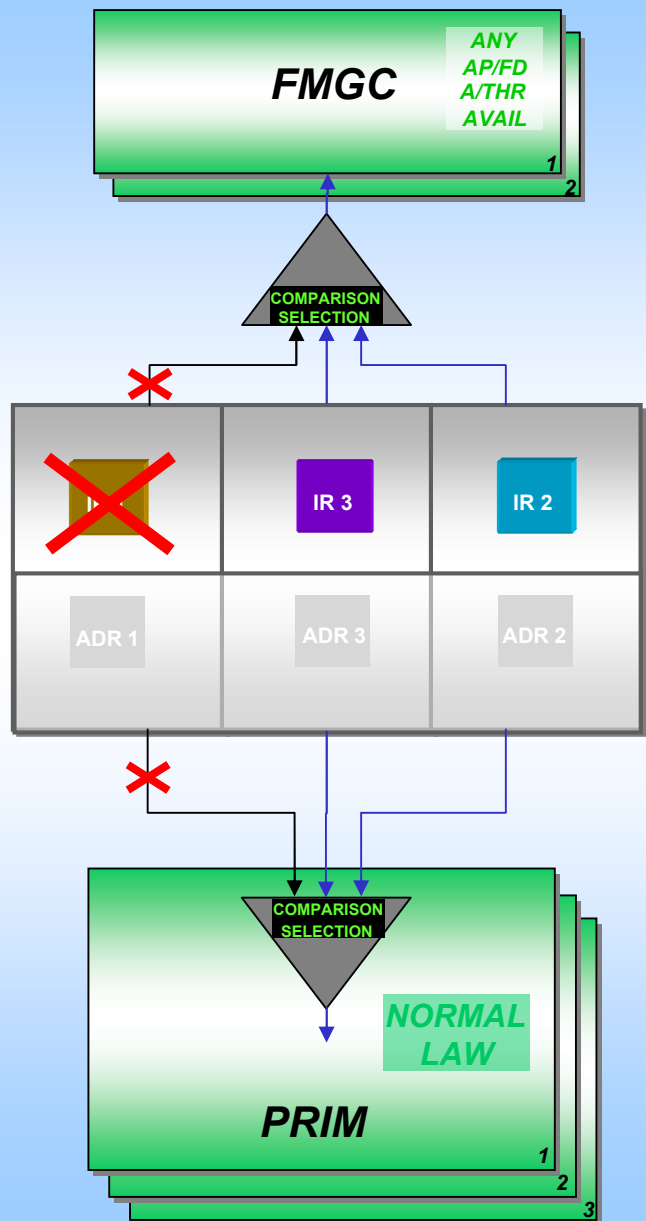

IR DISAGREE

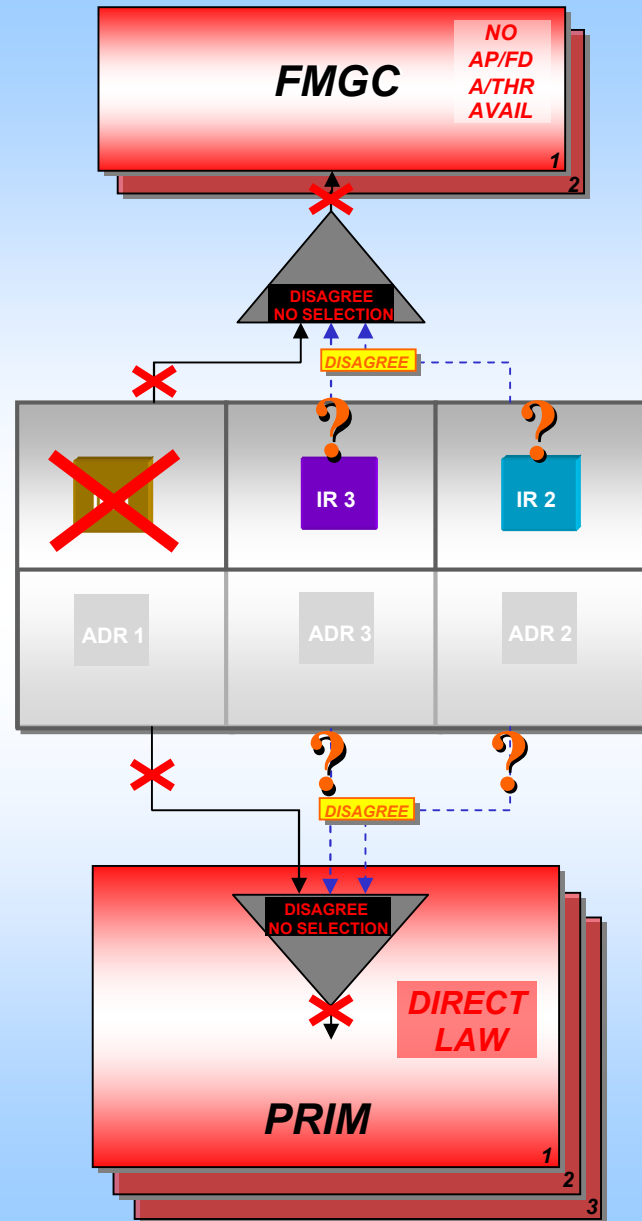

IR ARCHITECTURE (2/2)

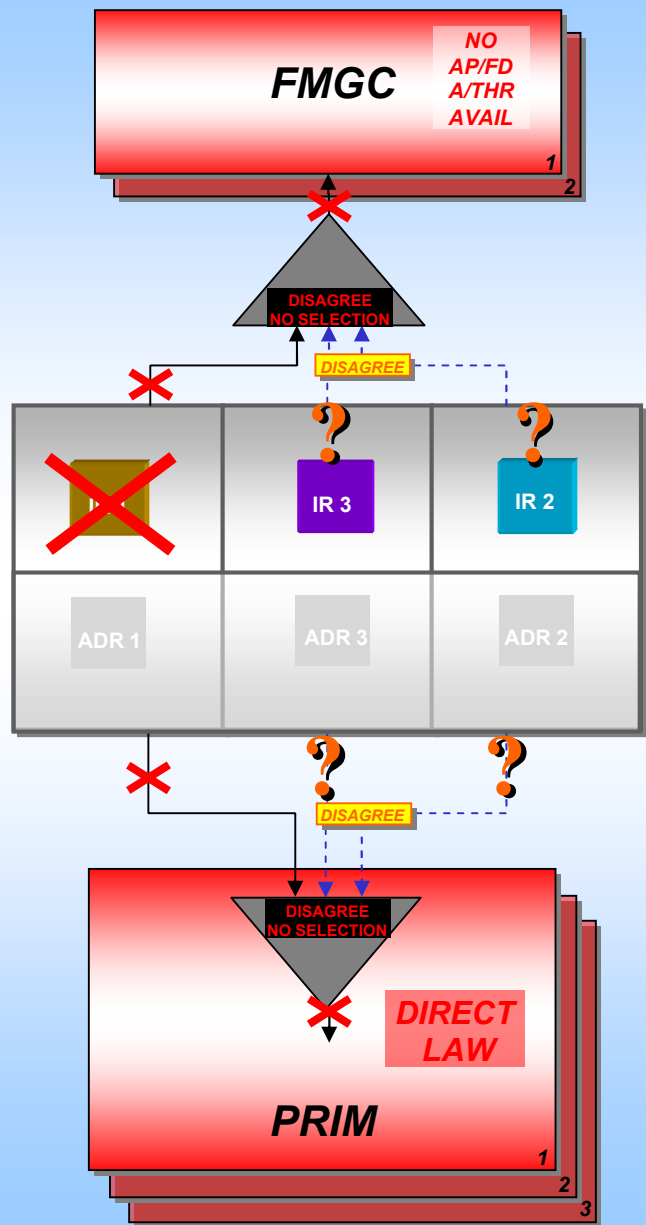

CREW ACTION

FAULTY IR OFF



PRIM RESET

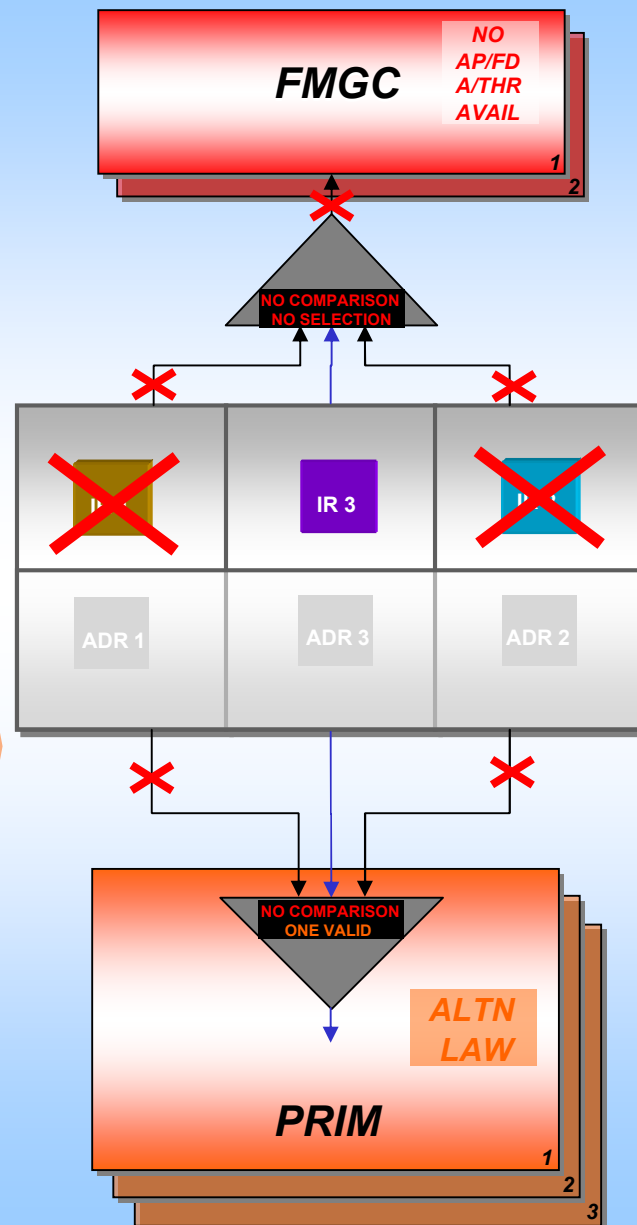

SYNTHESIS



Approach flown manually
with raw data : no AP
FD
A/THR
ALTN LAW

CONF 1

CONF 2

LANDING GEAR
EXTENSION

CONF 3

GO AROUND

