

# LR - PROCEDURES LIST

Temporary note :  
see highlight

<b>NORMAL</b>			<b>sl.</b>
01 COCKPIT PREPARATION	<b>MAN</b>		4
02 BEFORE START- ENGINE START-AFTER START	<b>MAN</b>		5
03 TAXI-BTO	<b>MAN</b>		7
04 TAKEOFF	<b>AUTO</b>	<b>FROZEN</b>	8
05 CLIMB	<b>AUTO</b>	<b>FROZEN</b>	10
06 CRUISE	<b>MAN</b>		12
07 DE SCENT	<b>MAN</b>		14
08 ILS_APP	<b>AUTO</b>	<b>FROZEN</b>	15
09 GSmini	<b>MAN</b>	<b>FROZEN</b>	17
10 NPA_MANAGED	<b>AUTO</b>	<b>FROZEN</b>	18
11 NPA_SELECTED	<b>AUTO</b>	<b>FROZEN</b>	19
12 GO_AROUND	<b>AUTO</b>	<b>FROZEN</b>	20
13 AFTER LANDING - PARKING - SECURING	<b>MAN</b>		21
14 RNAV	<b>AUTO</b>	<b>FROZEN</b>	22

<b>ABNORMAL *</b>			<b>sl.</b>
ECAM PHILOSOPHY	<b>MAN</b>		24
DUAL ADR FAULT	<b>MAN</b>		25
DUAL RA	<b>MAN</b>		26
DUAL_HYD	<b>MAN</b>		27
EIS FAIL SWITCHING	<b>MAN</b>		28
ELEV REDUND LOST	<b>MAN</b>		30
EMER ELEC	<b>MAN</b>		31
EMERGENCY DE SCENT	<b>MAN</b>		33
ENG FAILURE IN CRZ DRIFT DWN DAMAGE	<b>MAN</b>		34
ENG FAILURE IN CRZ STD NO DAMAGE	<b>MAN</b>		35
Engine start failure	<b>MAN</b>		36
EO AFTER TO_Damage	<b>AUTO</b>	<b>FROZEN</b>	37
EO AFTER TO_No Damage	<b>AUTO</b>	<b>FROZEN</b>	38
FMGC FAILURE	<b>MAN</b>		39
FLAPS_LOCKED	<b>MAN</b>		40
Fuel imbalance	<b>MAN</b>		41
IR DISCREPANCY	<b>MAN</b>		42
SLATS_FAULT	<b>MAN</b>		43
Smoke	<b>MAN</b>		44
Unreliable speed indication (pitot / static blocked)	<b>MAN</b>		45

\* **During Tutorial mode :**  
**If the Auto-Pilot is lost during an  
Abnormal Proc, the flight is frozen**

# CODES

➤ SLIDE TITLE :

ENG  
FAILURE at  
T/O  
sl. 1

➤ SIMULATION STATUS :

FROZEN

➤ INSTRUCTOR ACTION  
TO UNFREEZE :

UNFREEZE

➤ MANUAL TRANSITION :



➤ PARAMETER FOR AUTOMATIC TRANSITION :

200 ft

➤ A/C & FLIGHT STATUS :

Flight is  
initialised at  
Take-off

➤ FAILURE TRIGGERED :

ENG 2  
FAILURE  
triggered with  
DAMAGE  
after AP  
engaged

➤ INFORMATION PAGE (POP-UP) :

 FM & FL CHECK

# NORMAL PHASES

# LR - COCKPIT PREPARATION

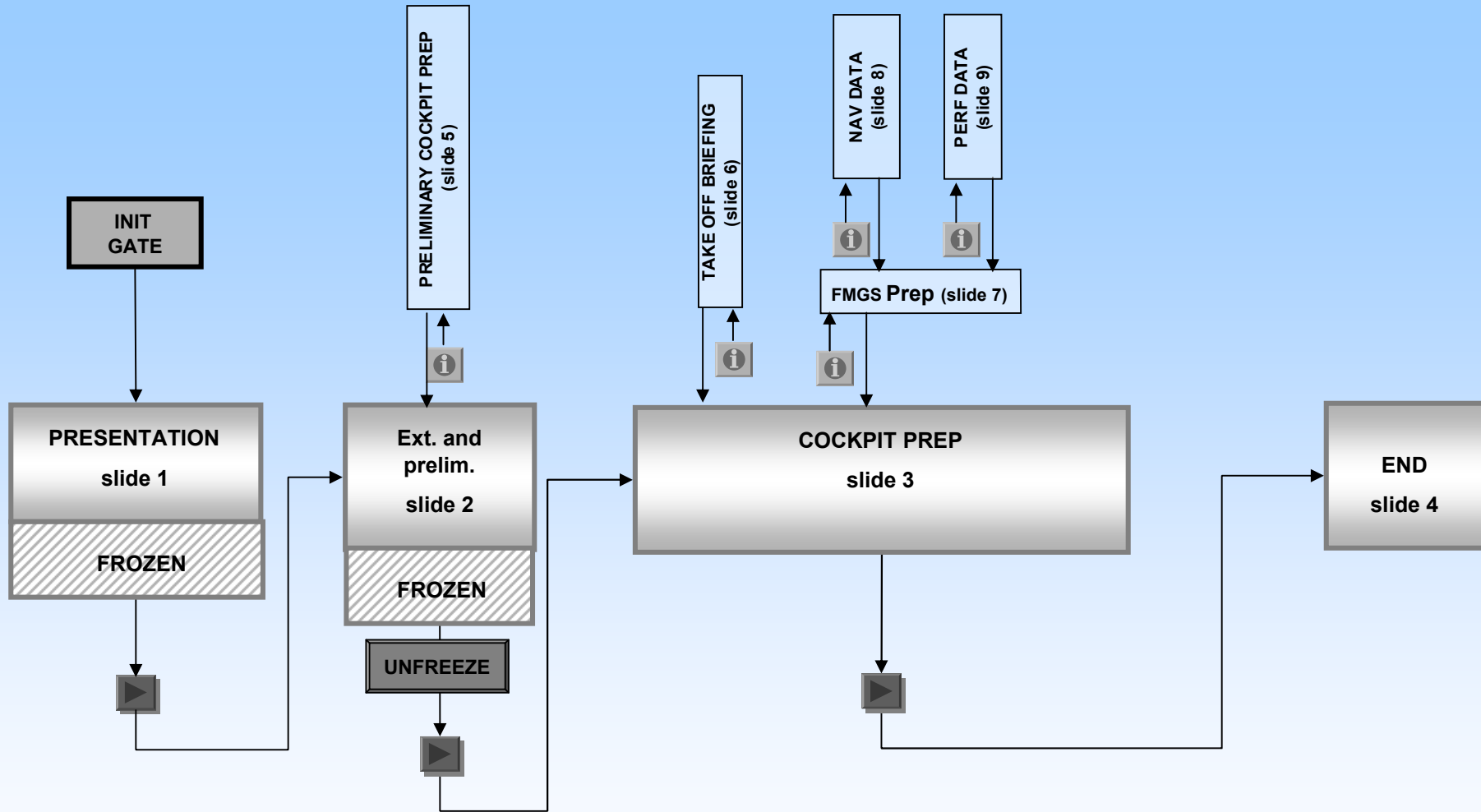

# A330 - BEFORE START – START – AFTER START

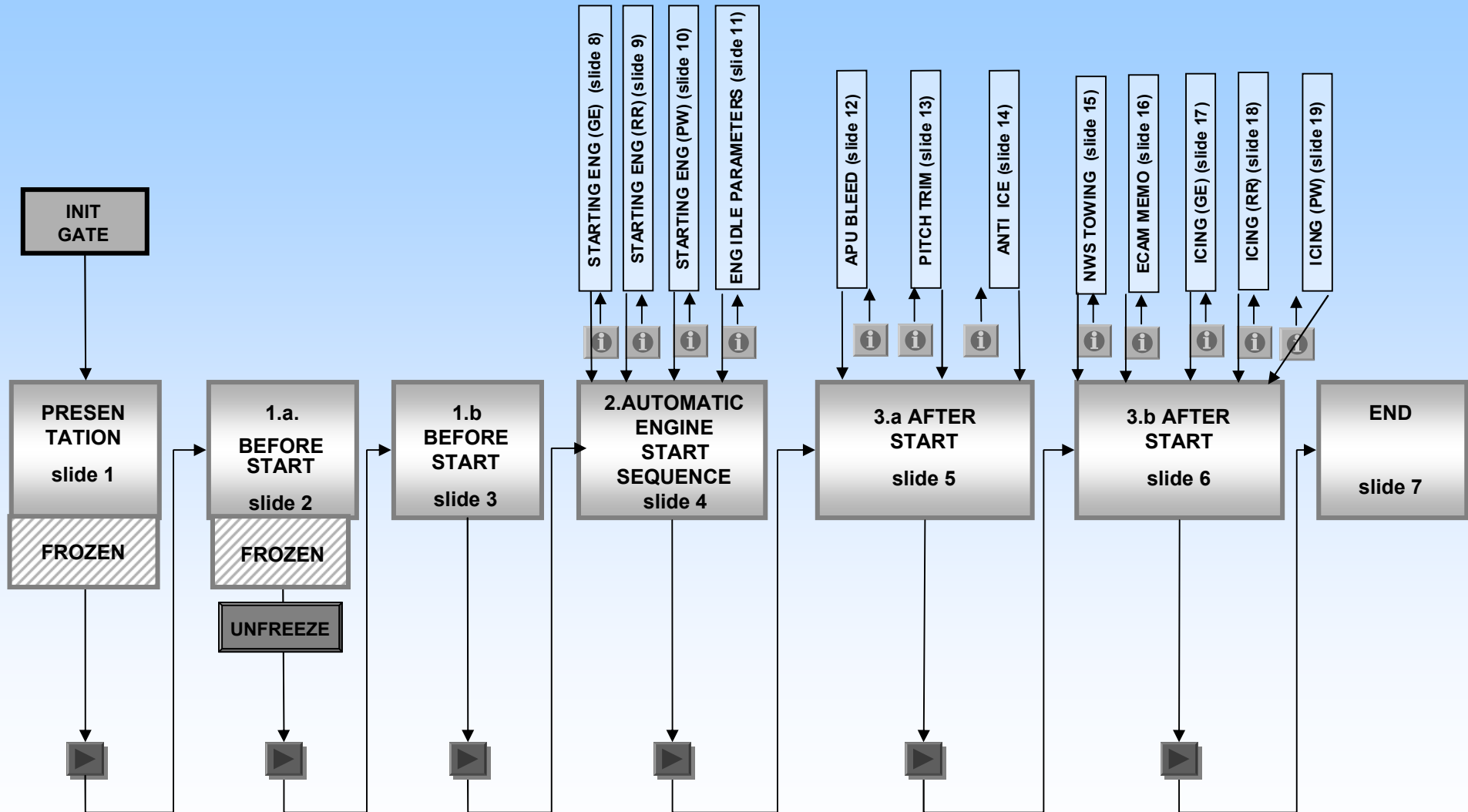

# A340 - BEFORE START – START – AFTER START

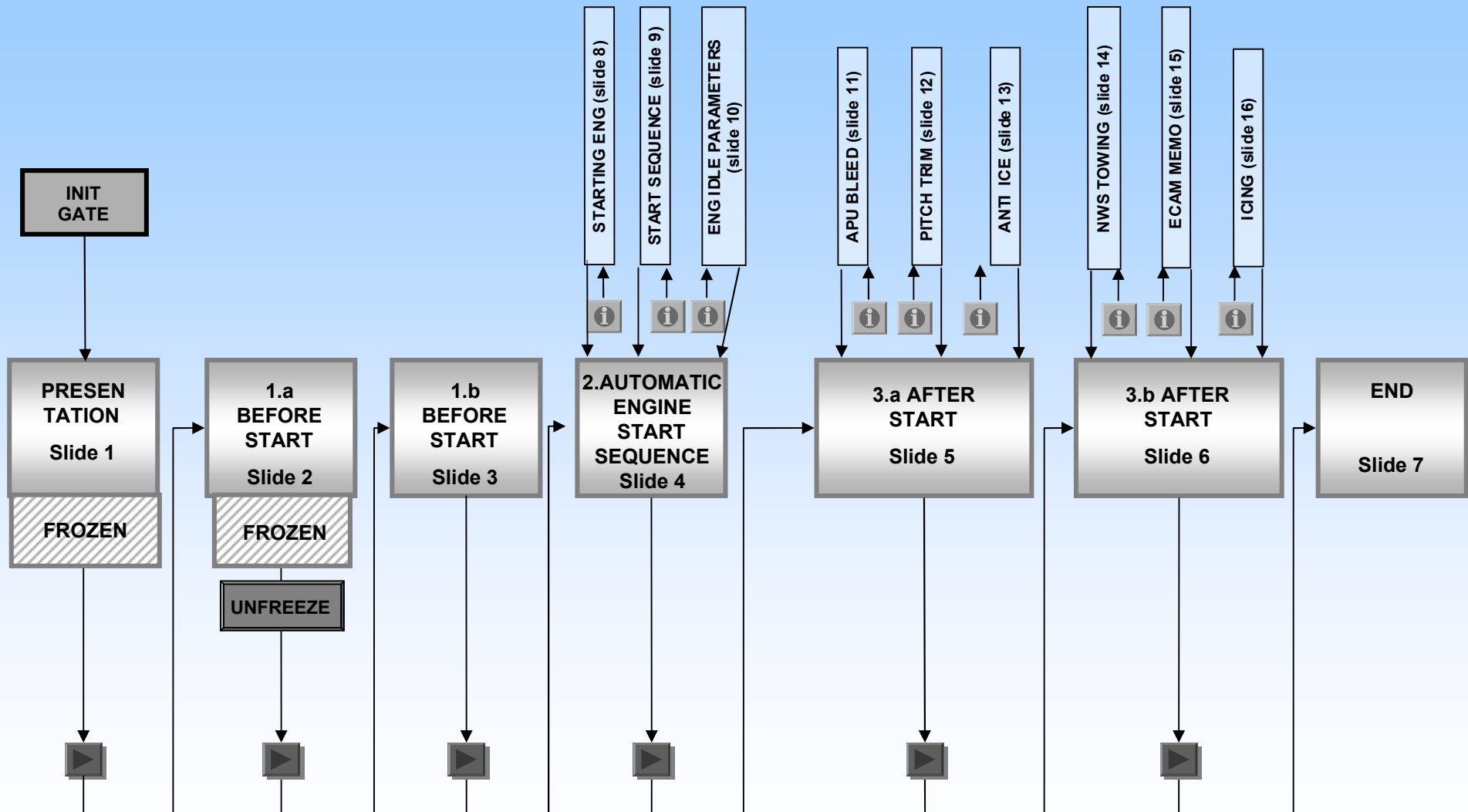

# LR - TAXI & BEFORE TAKE-OFF

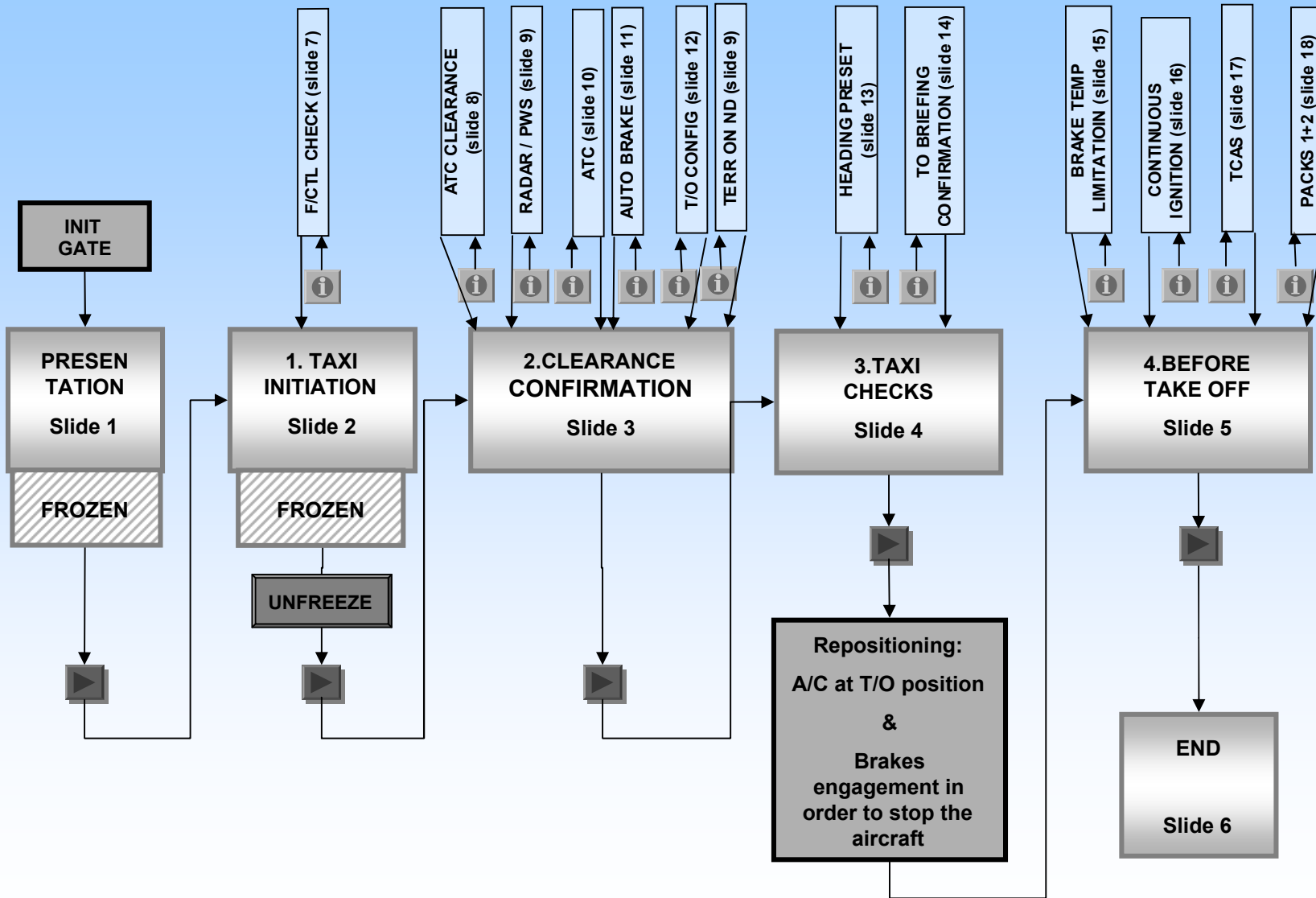

# LR - TAKE OFF

1 / 2

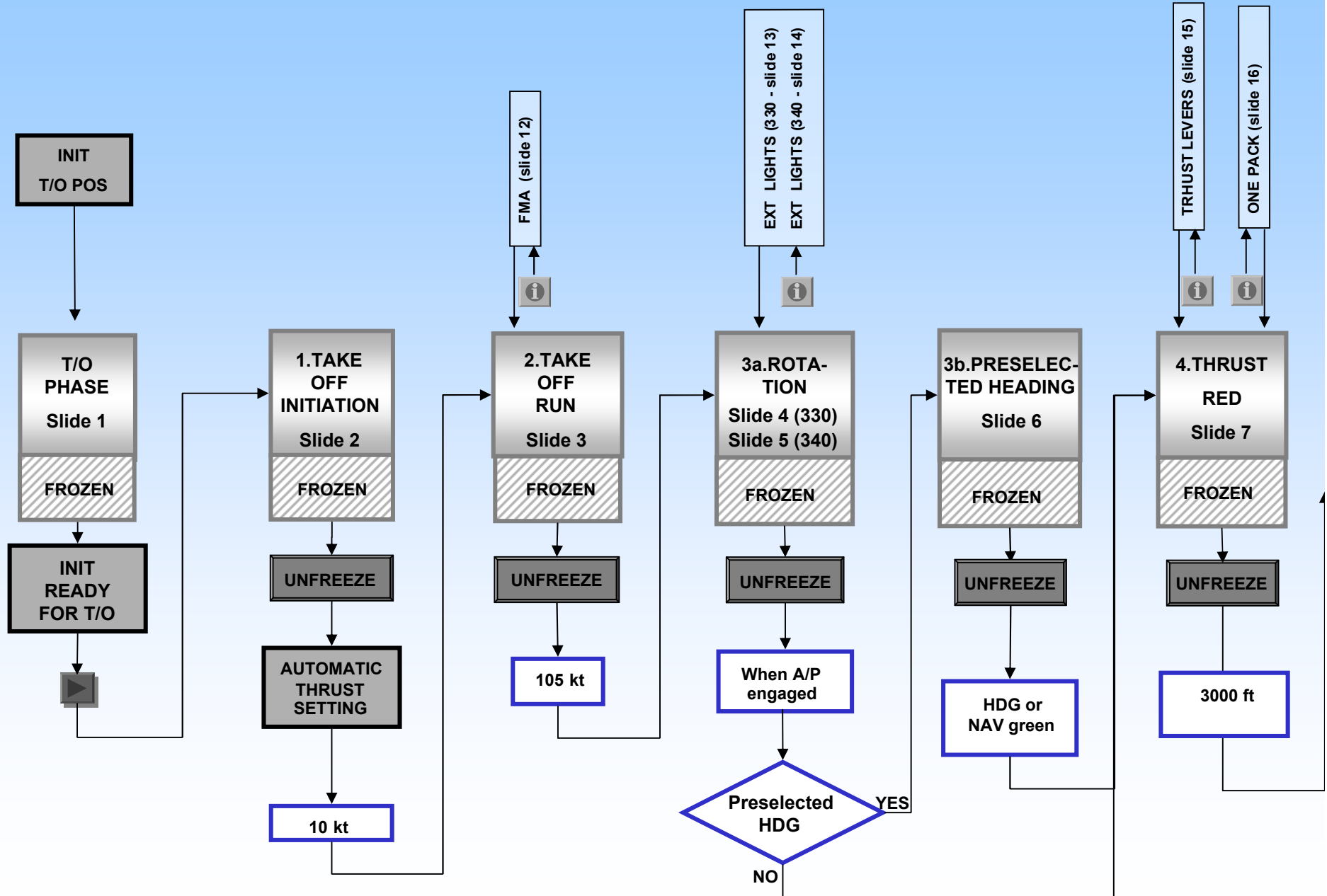



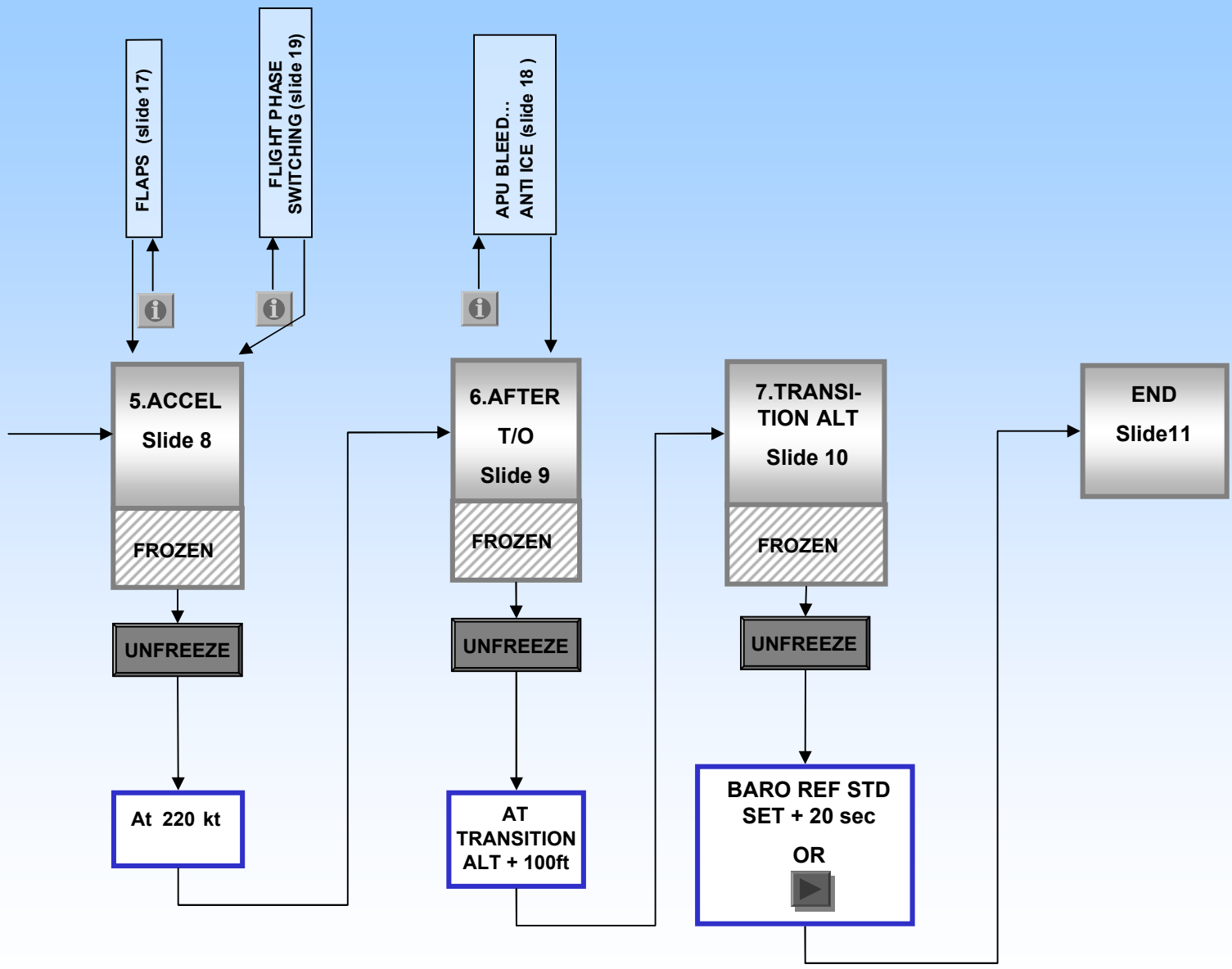

# LR - CLIMB

1 / 2

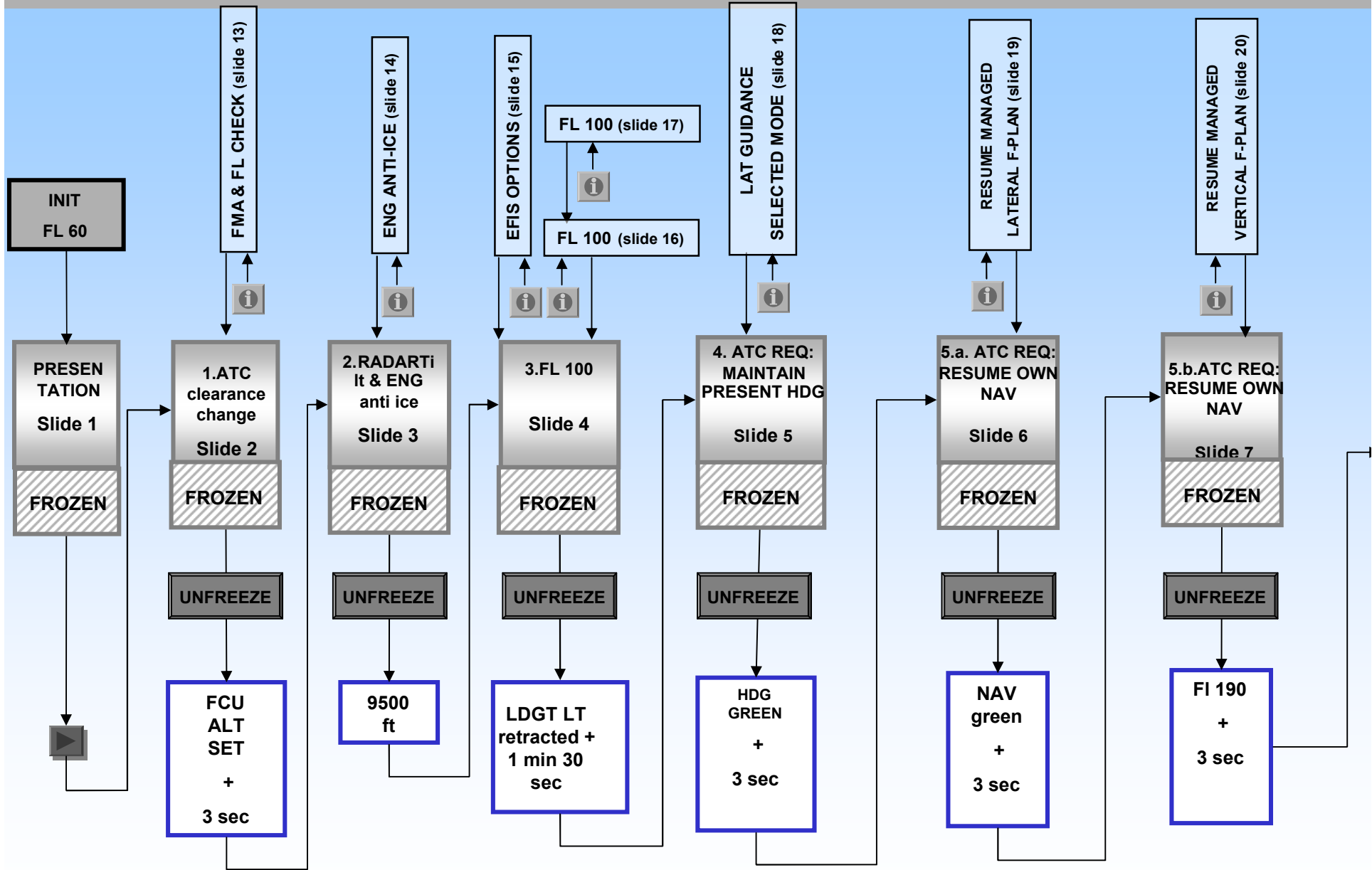

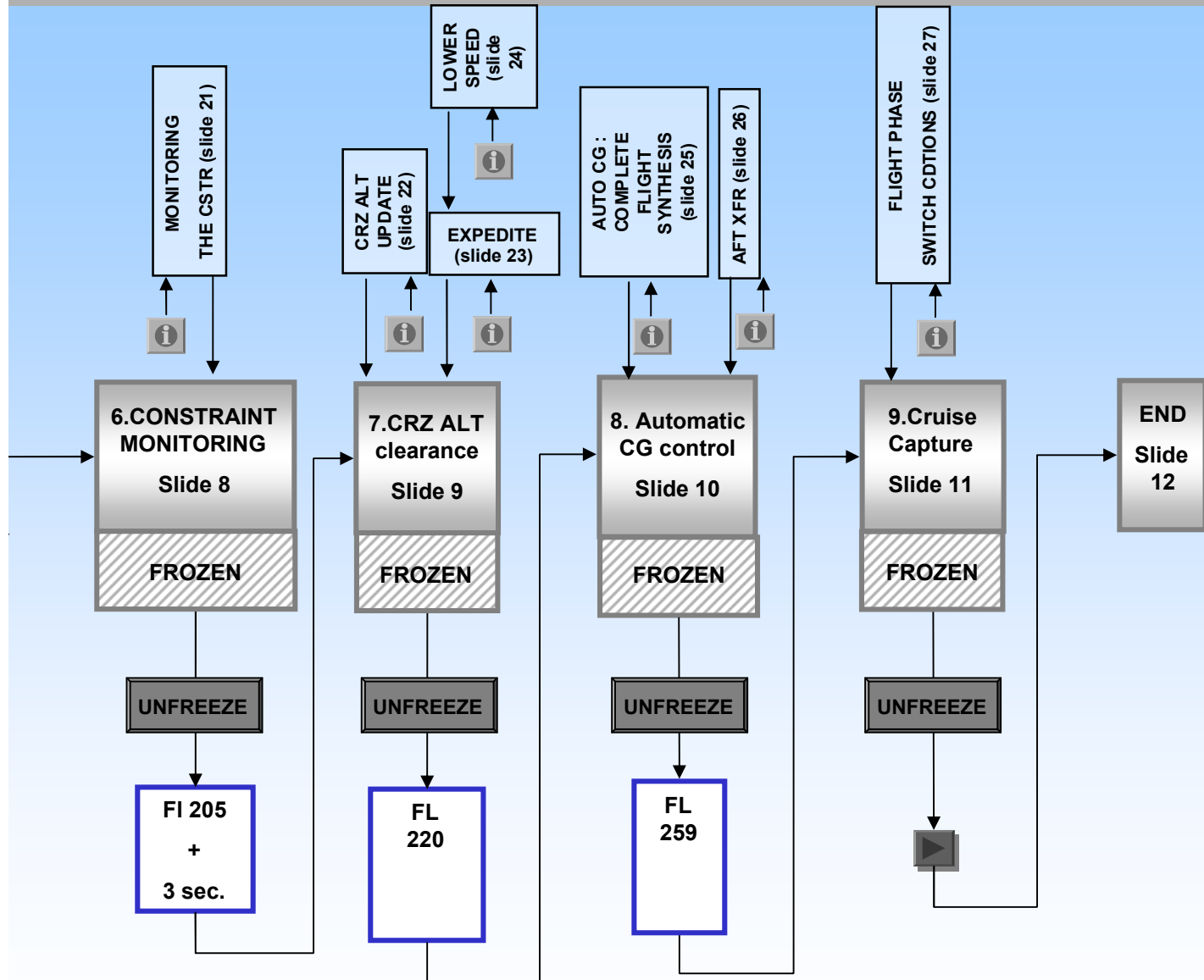

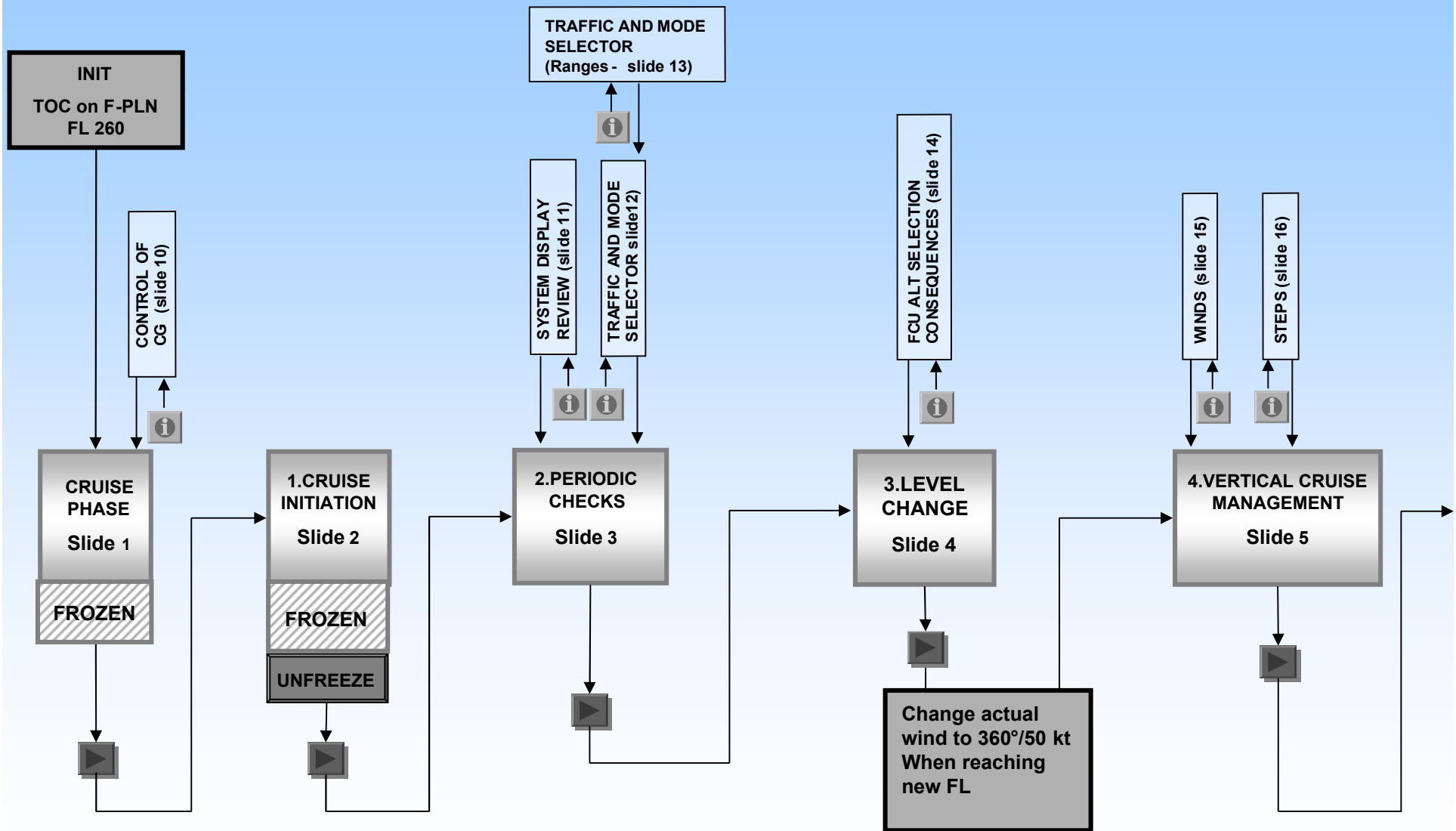

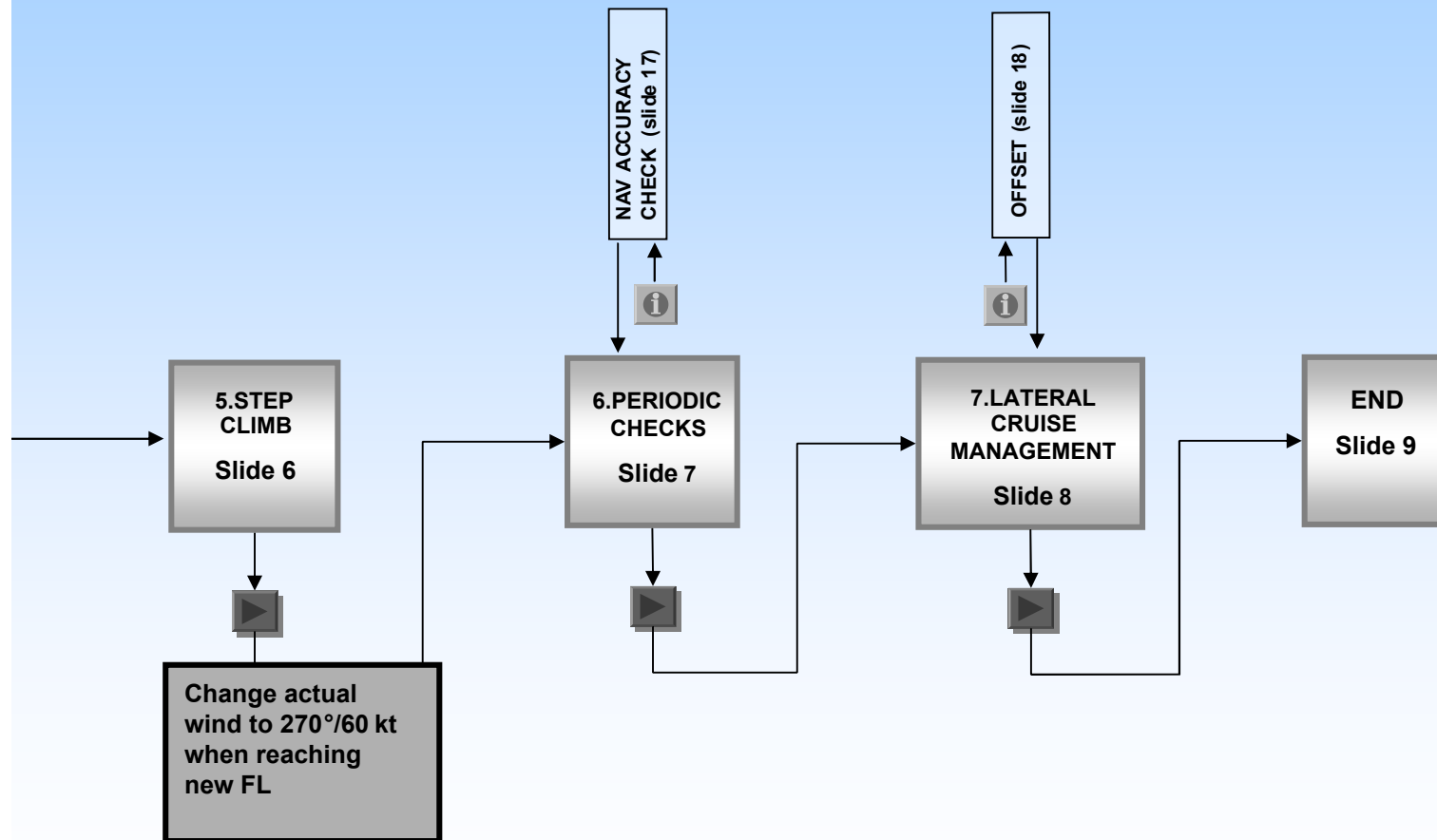

# LR - DESCENT

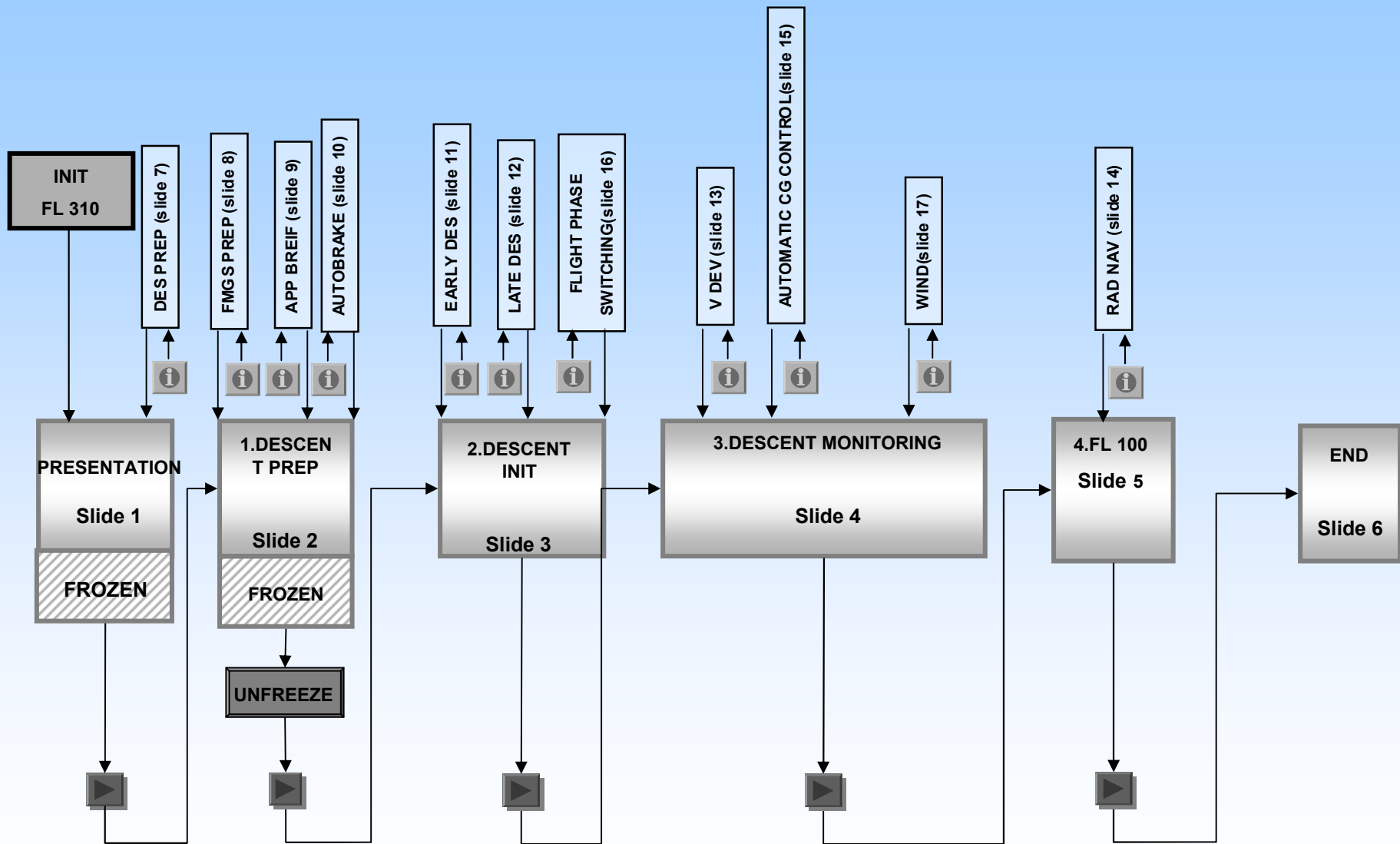

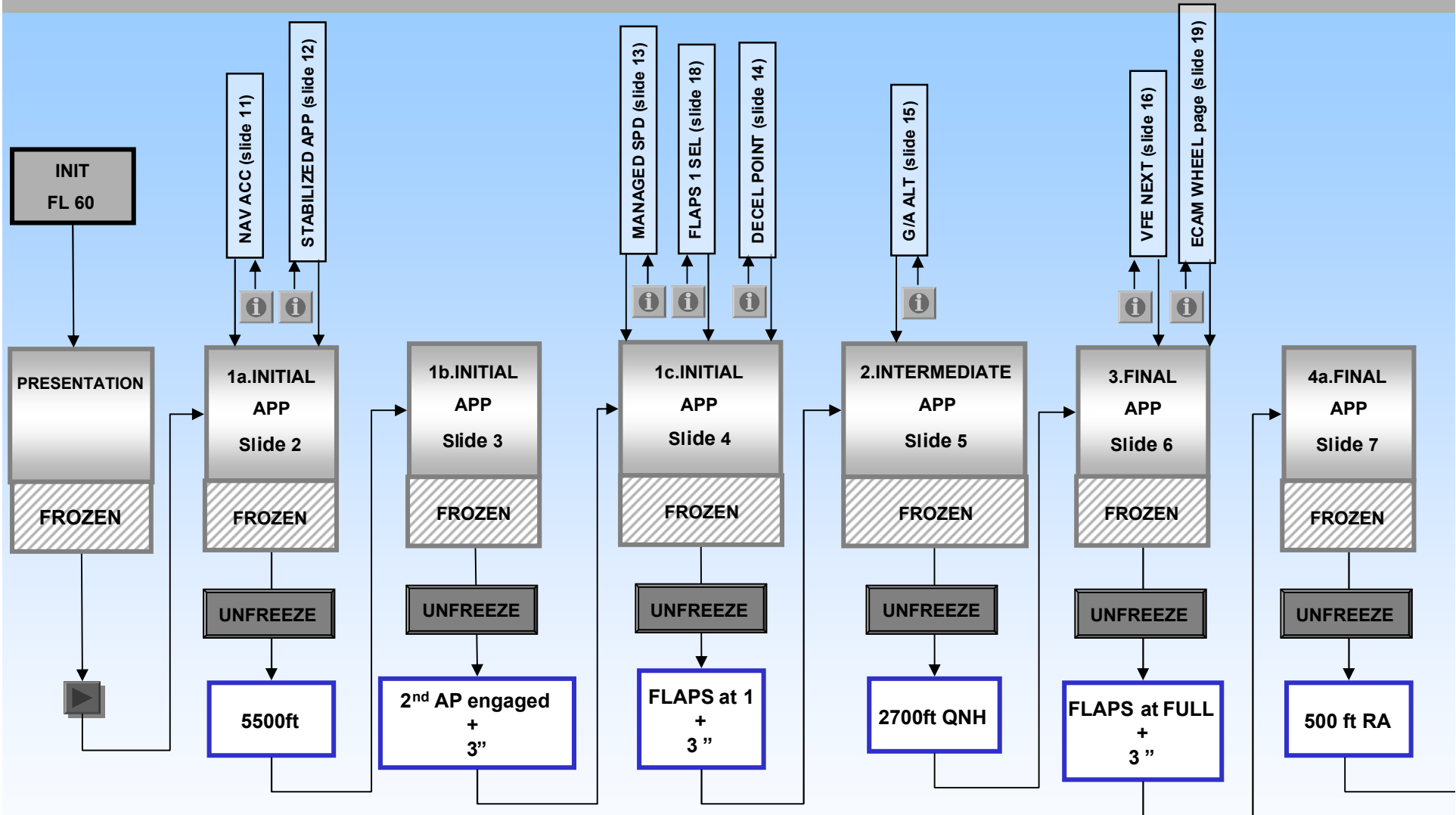

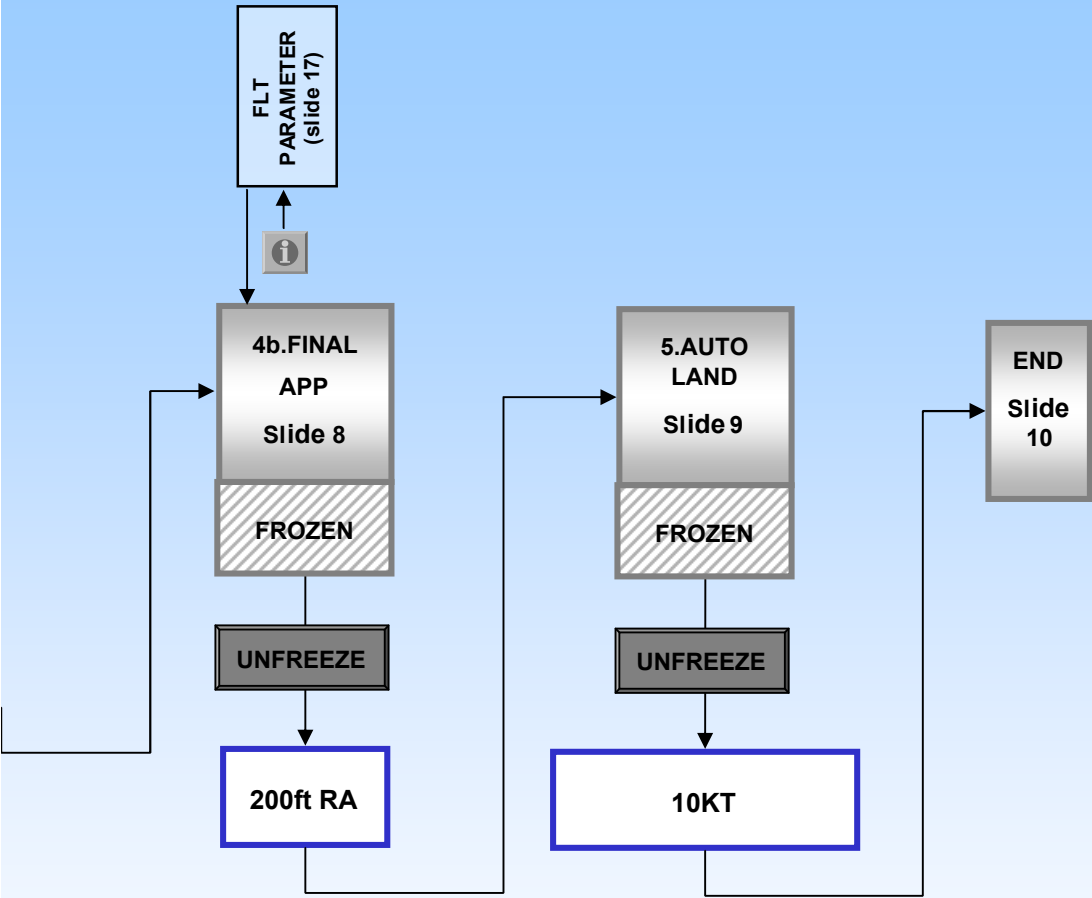



# LR - GROUND SPEED MINI

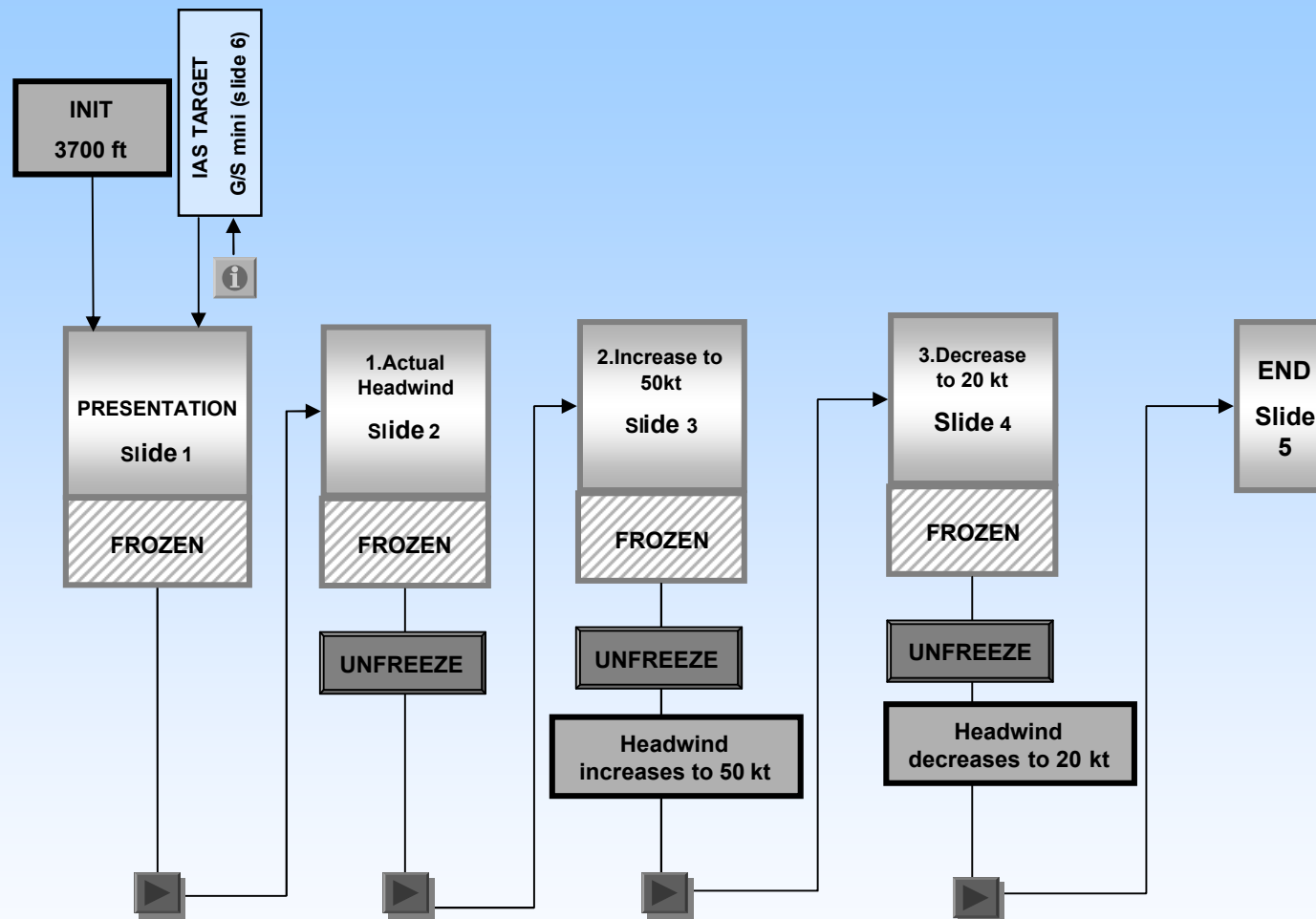

# LR - NPA MANAGED

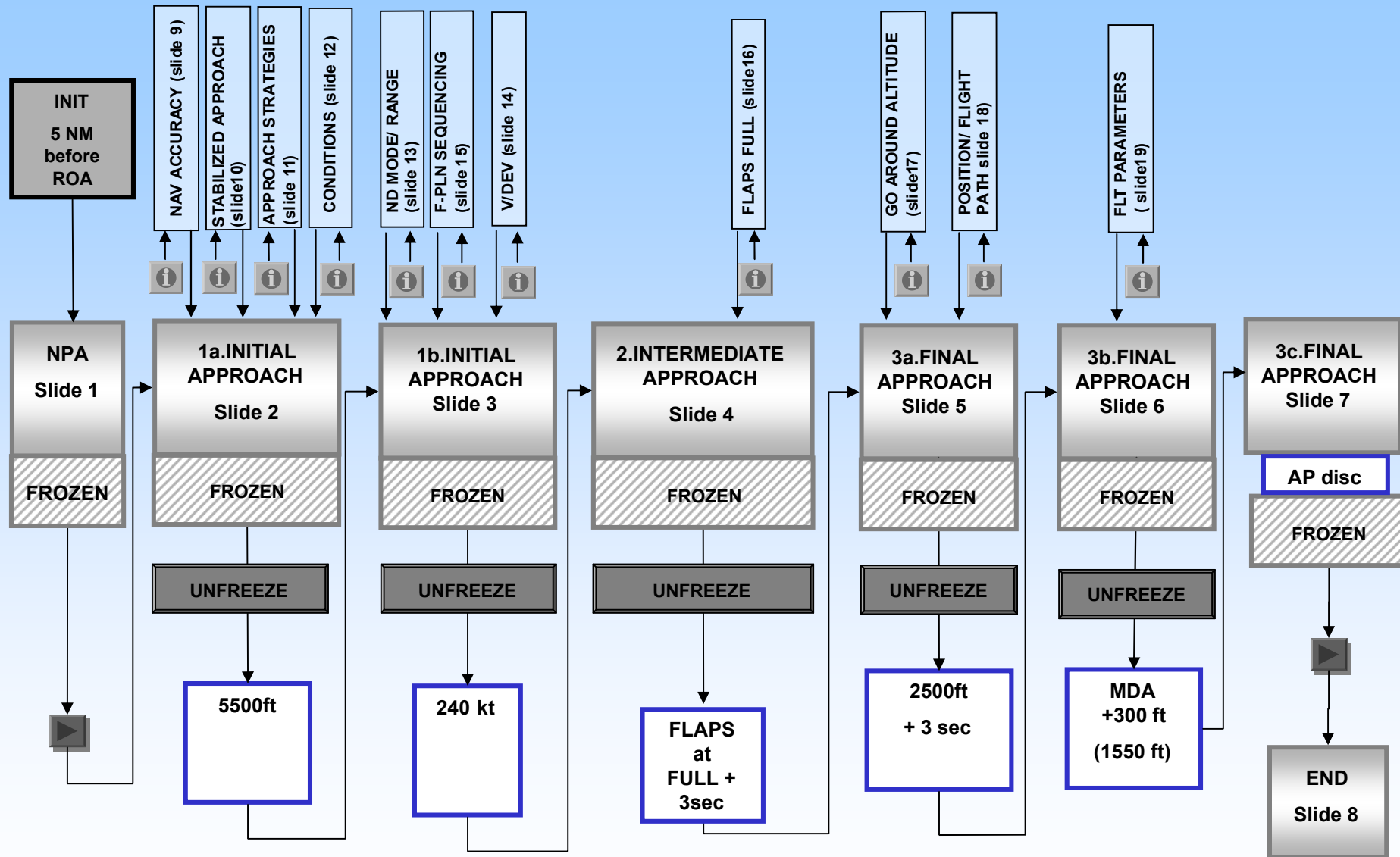

# LR - NPA SELECTED

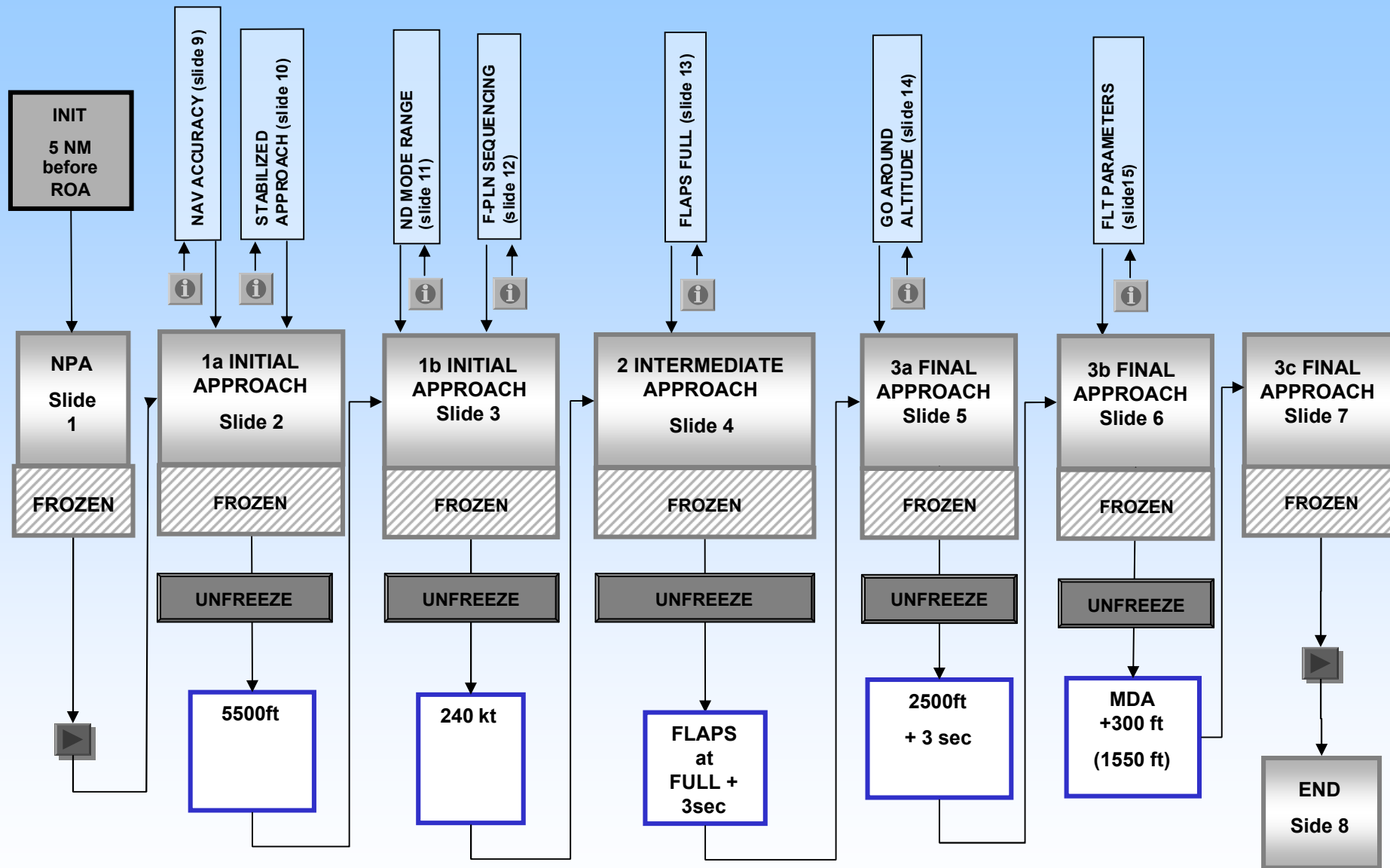

# LR - GO AROUND

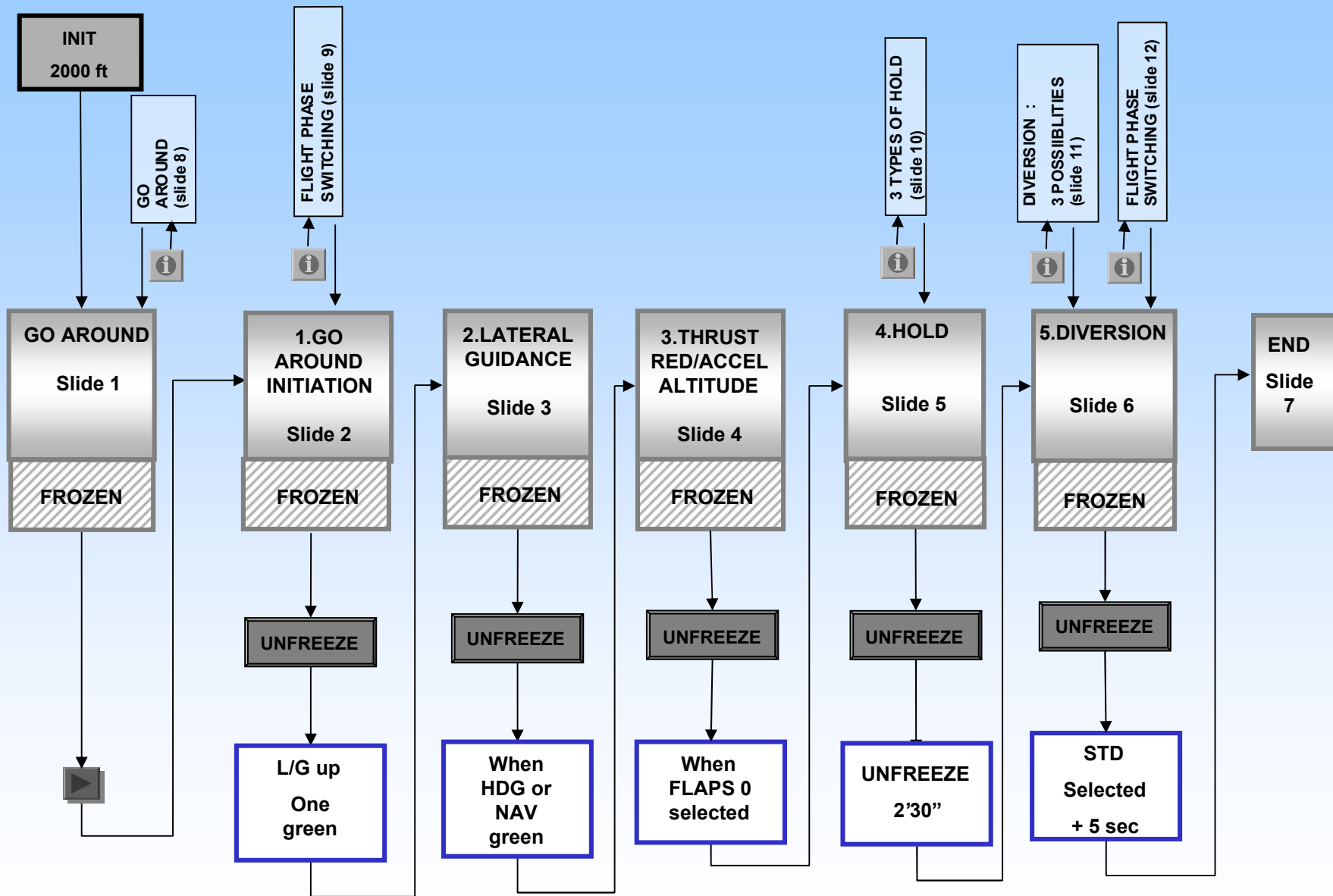

# LR - AFTER LANDING – PARKING – SECURING

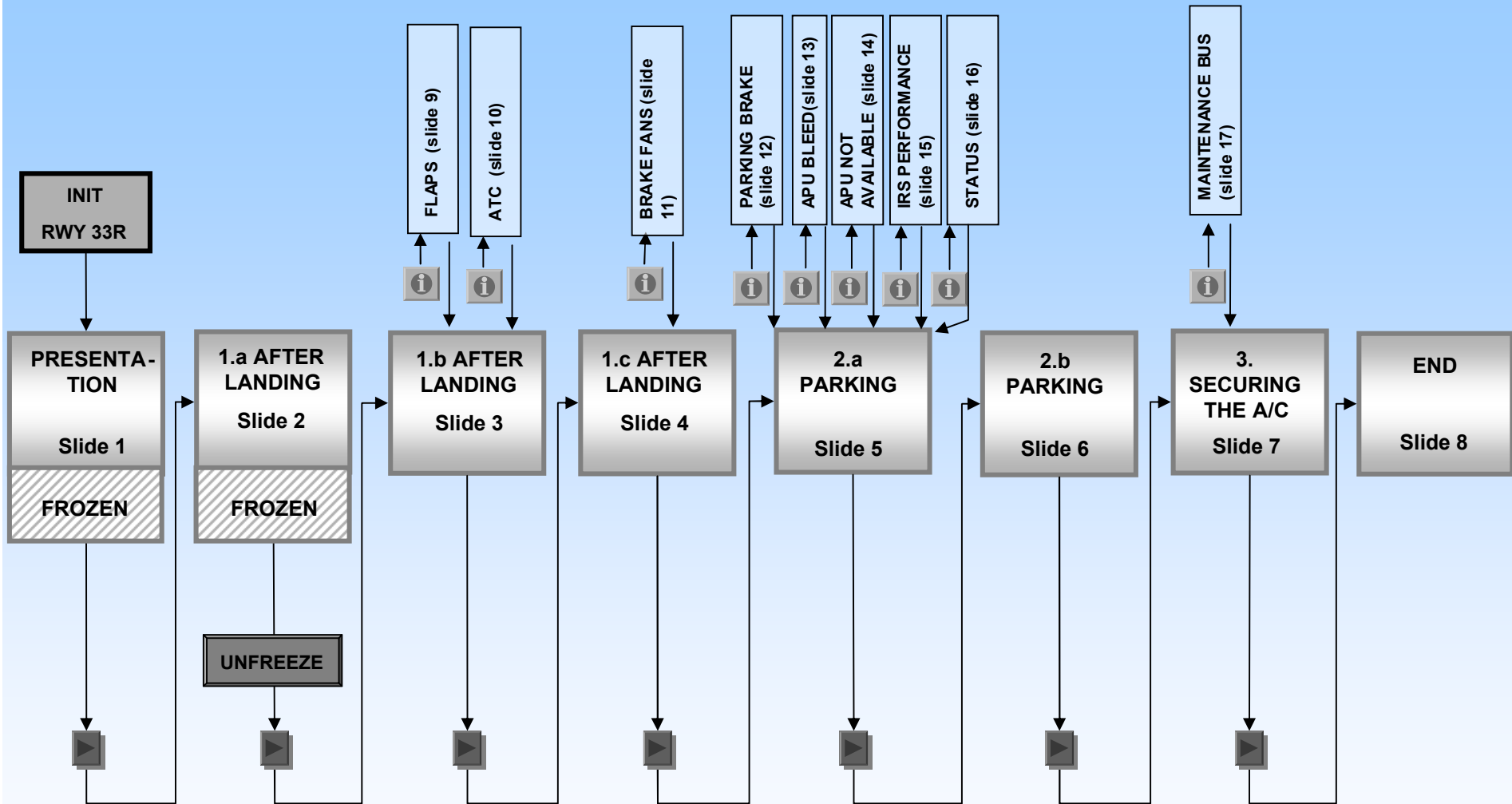

# LR - RNAV

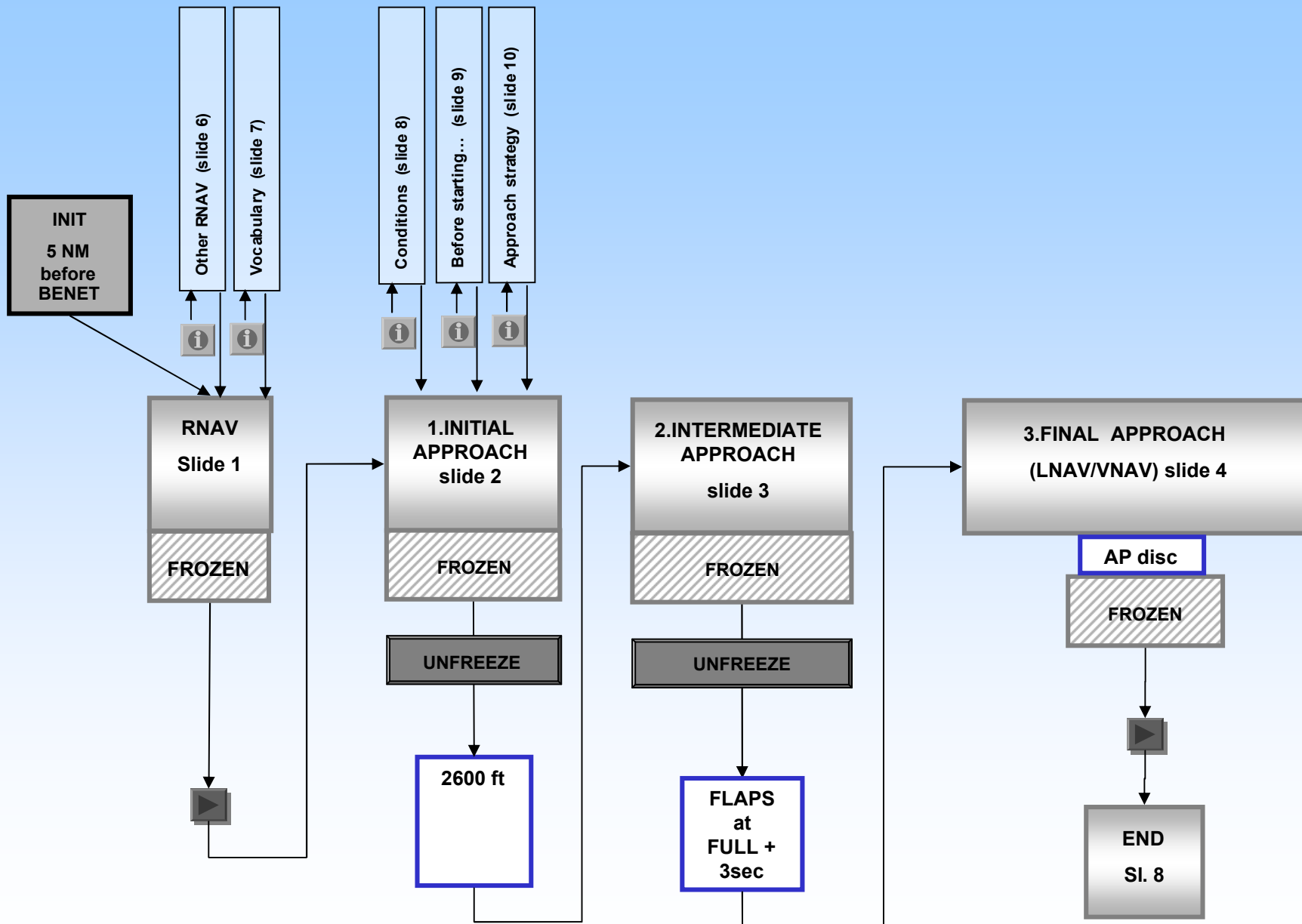

# ABNORMAL PHASES

# LR- ECAM PHILOSOPHY DYNAMIC CHART

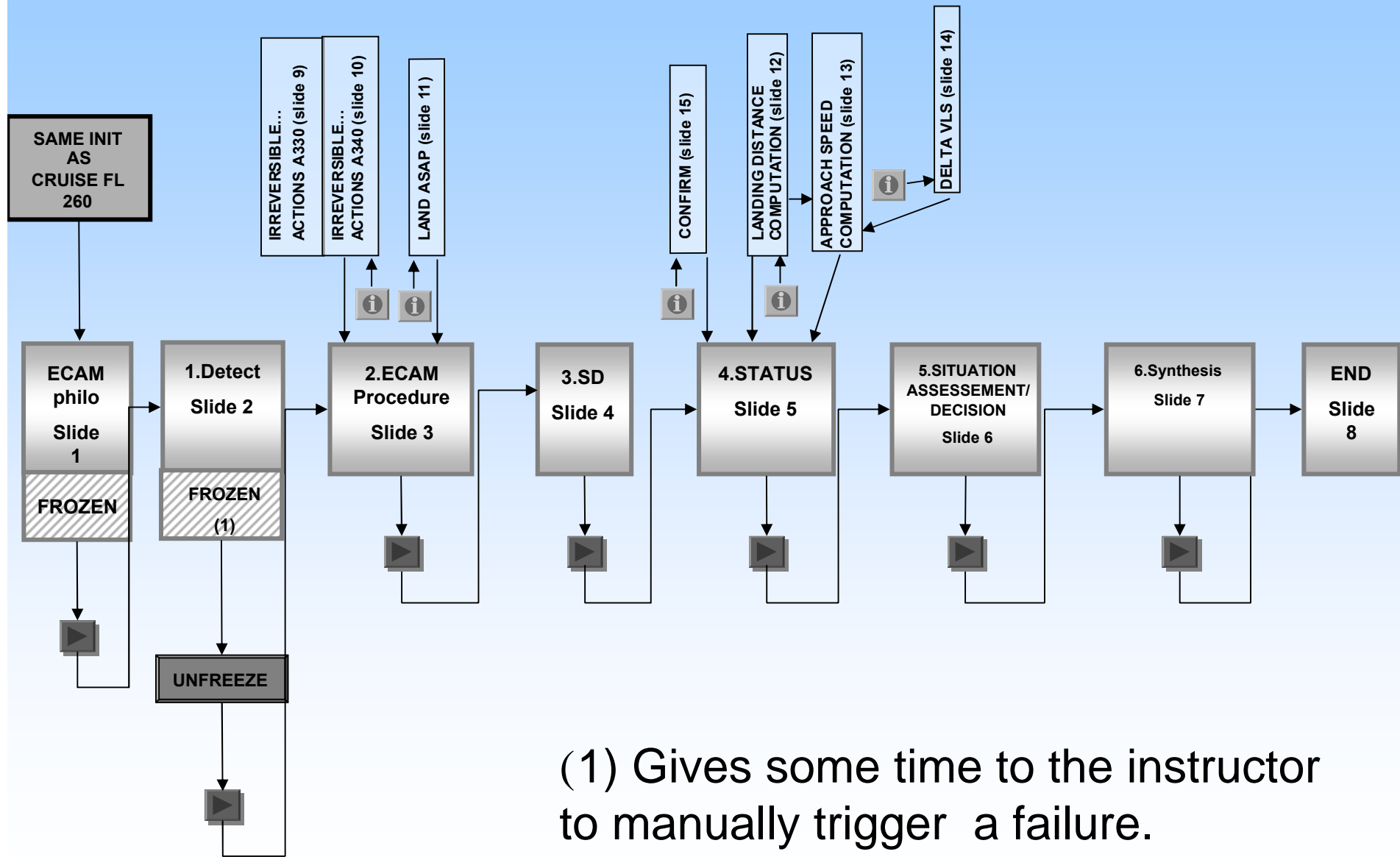



# LR - DUAL ADR FAULT

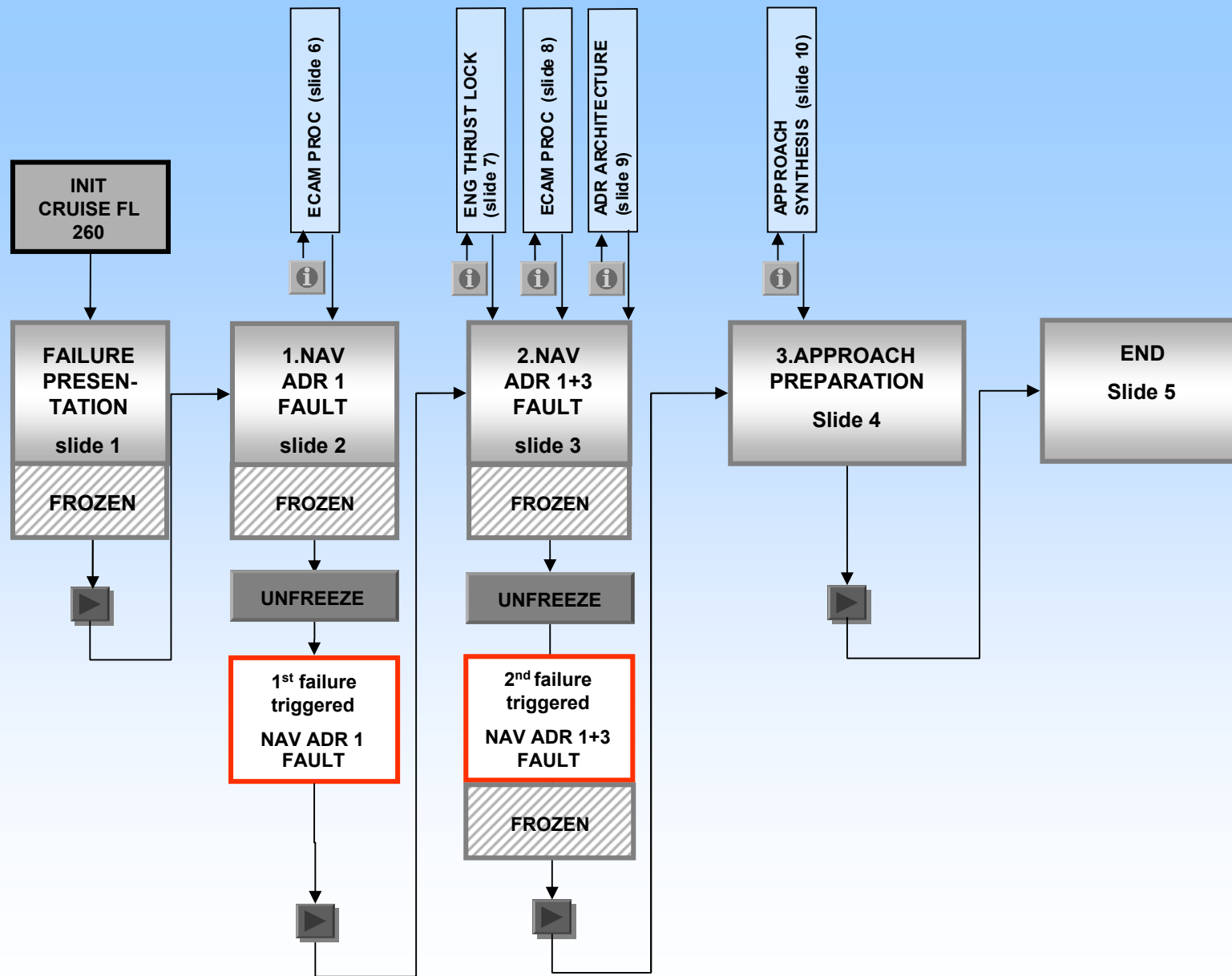

# LR- NAV : RA 1+2 FAULT

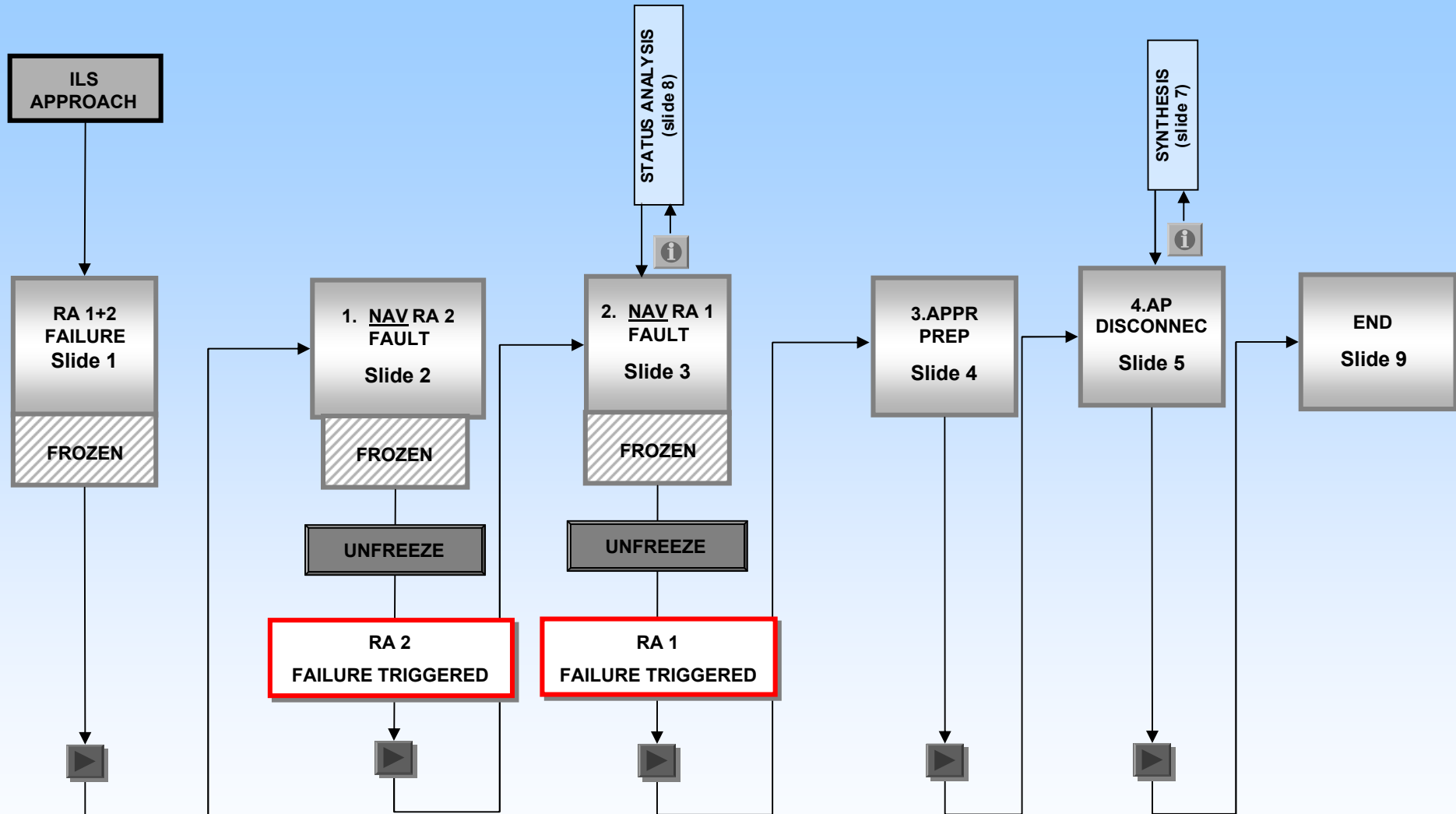

# LR- G + B SYS LO PR

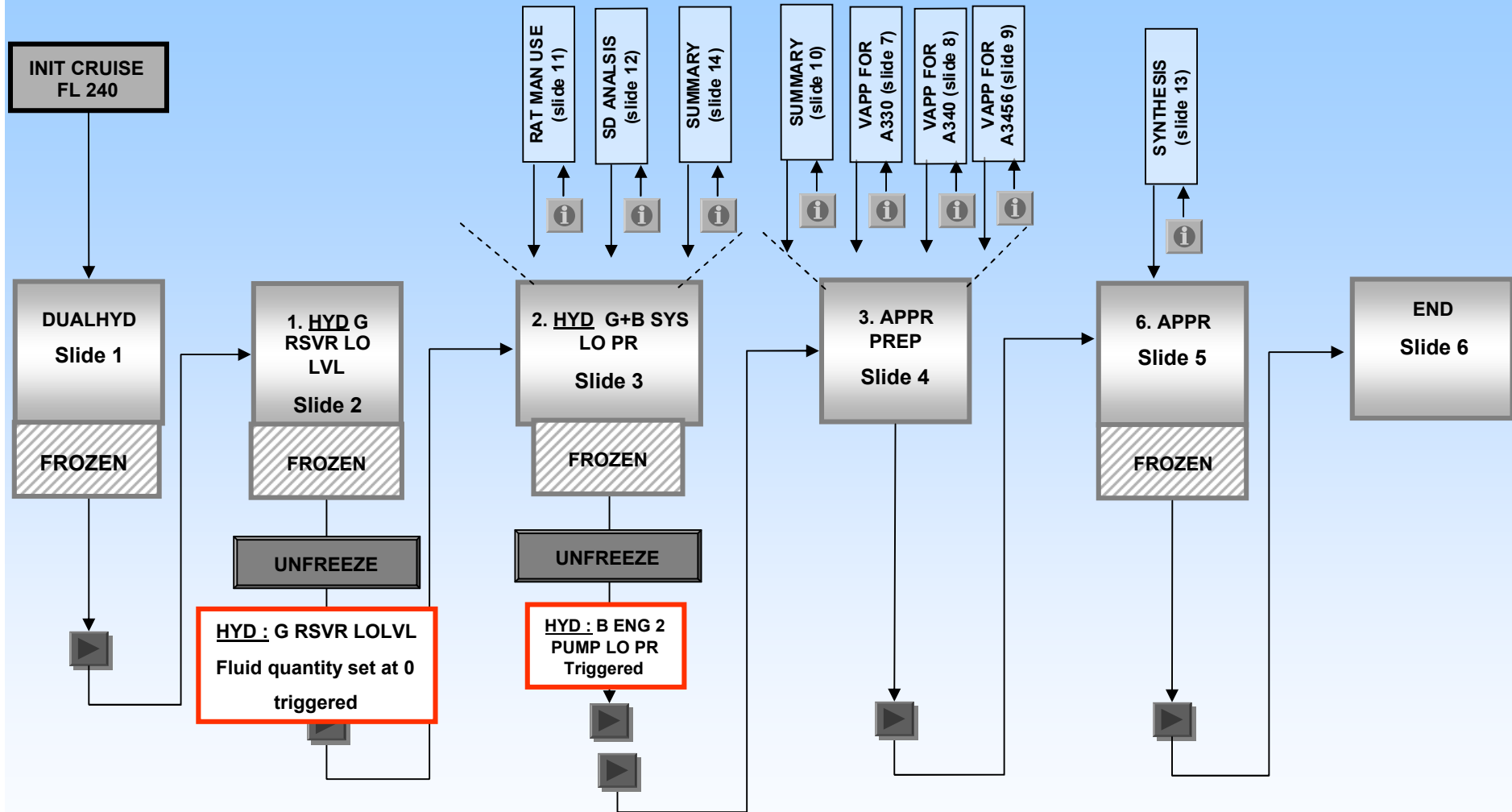

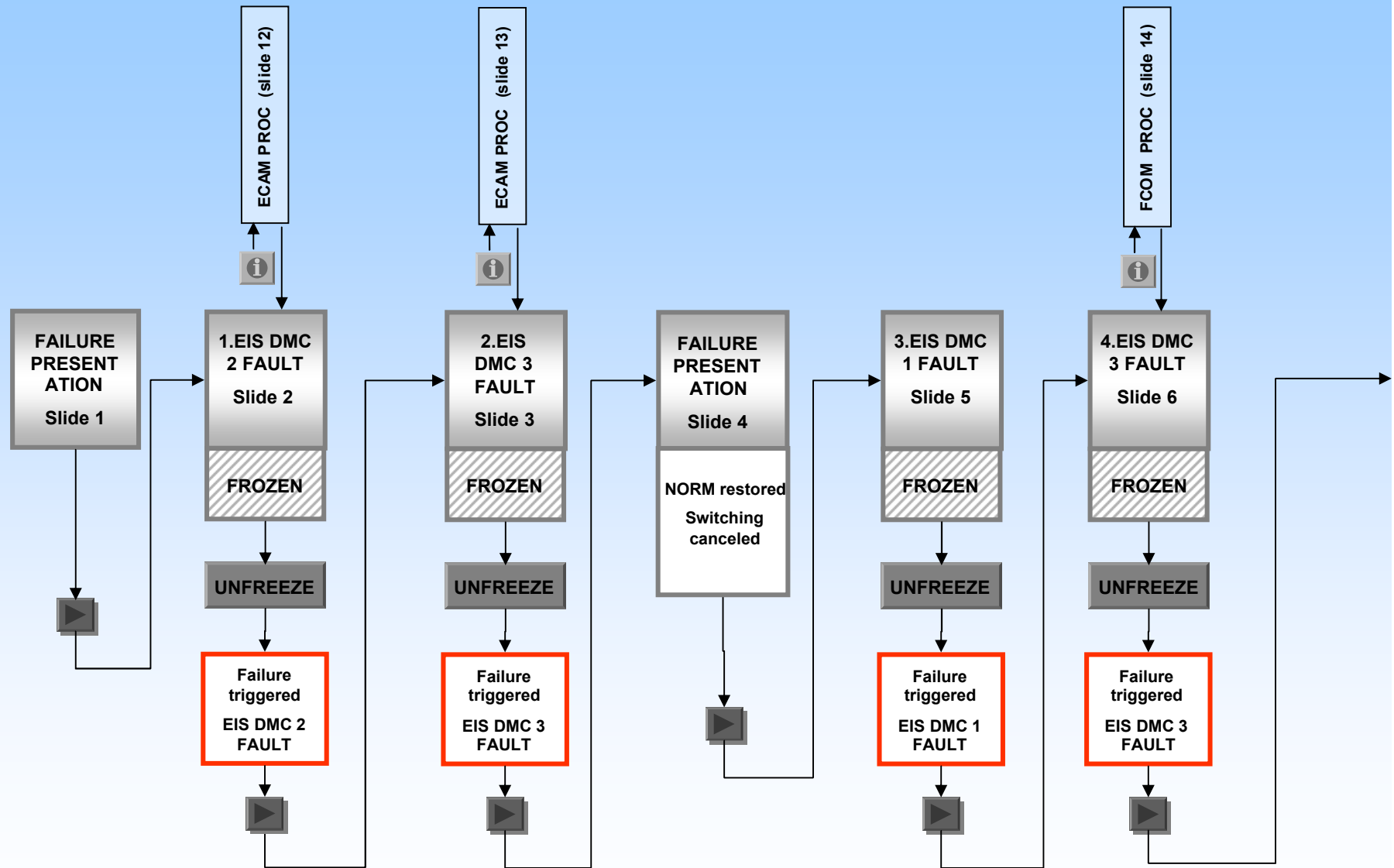

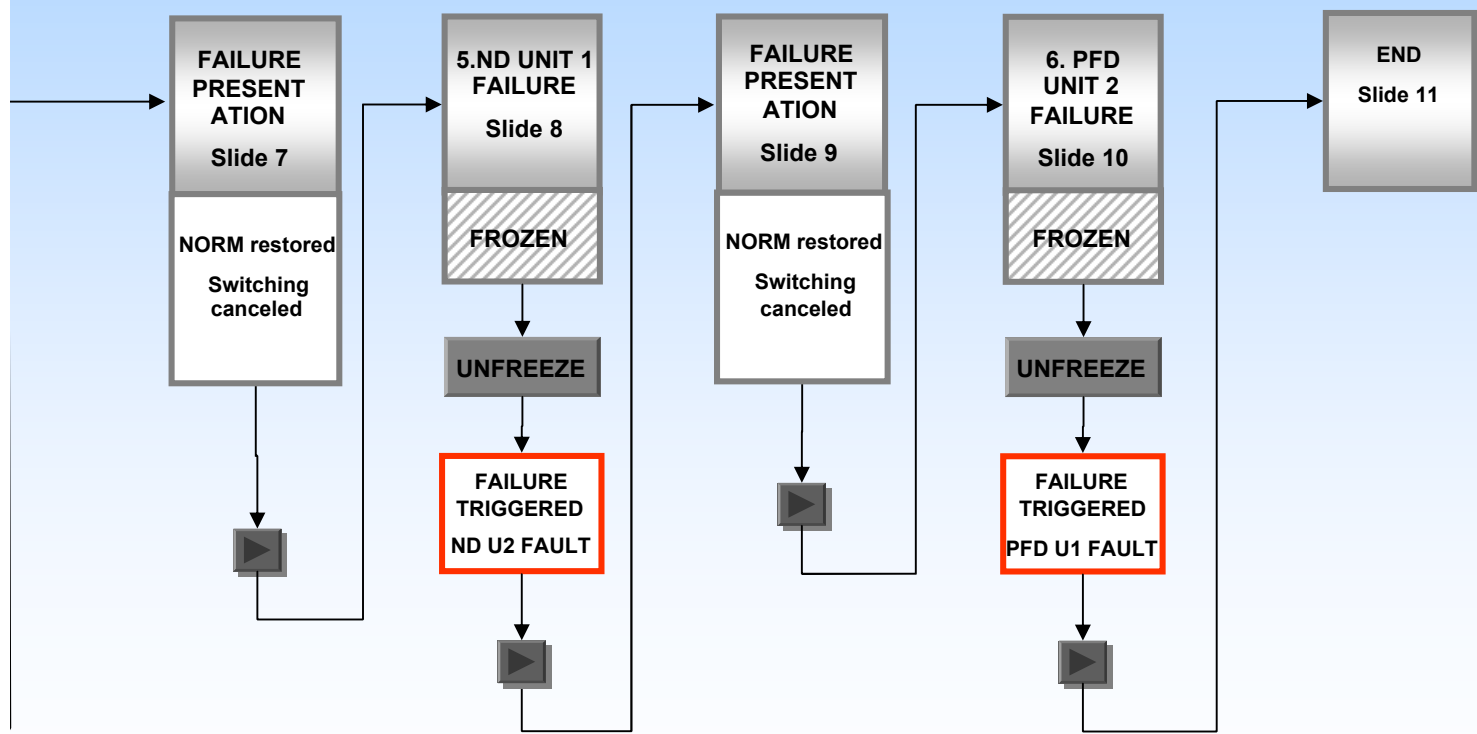

# LR - EIS FAILURES / SWITCHING

Temporary note:  
see highlight 1/2

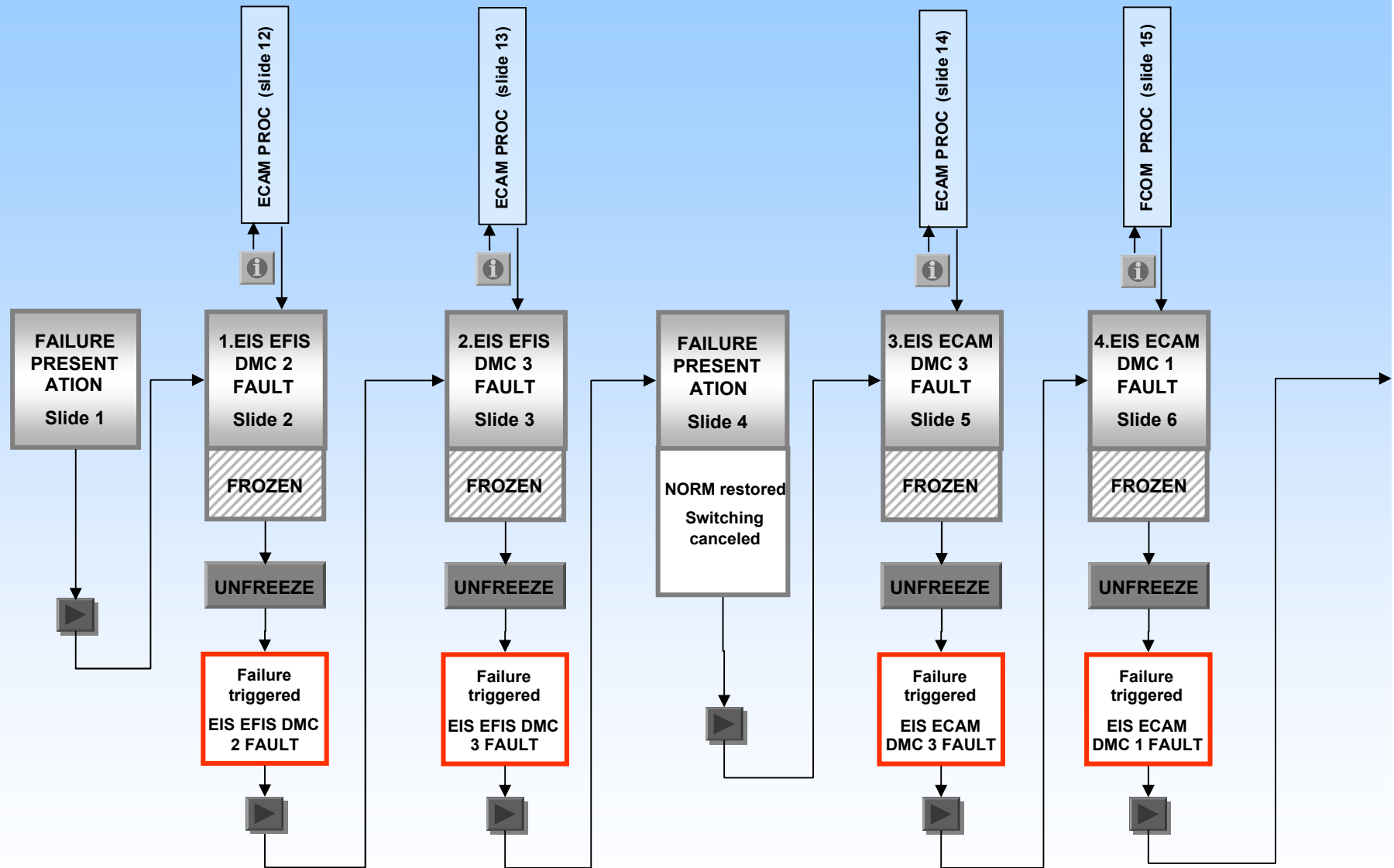

# LR - EIS FAILURES / SWITCHING

Temporary notes  
see highlight 2/2

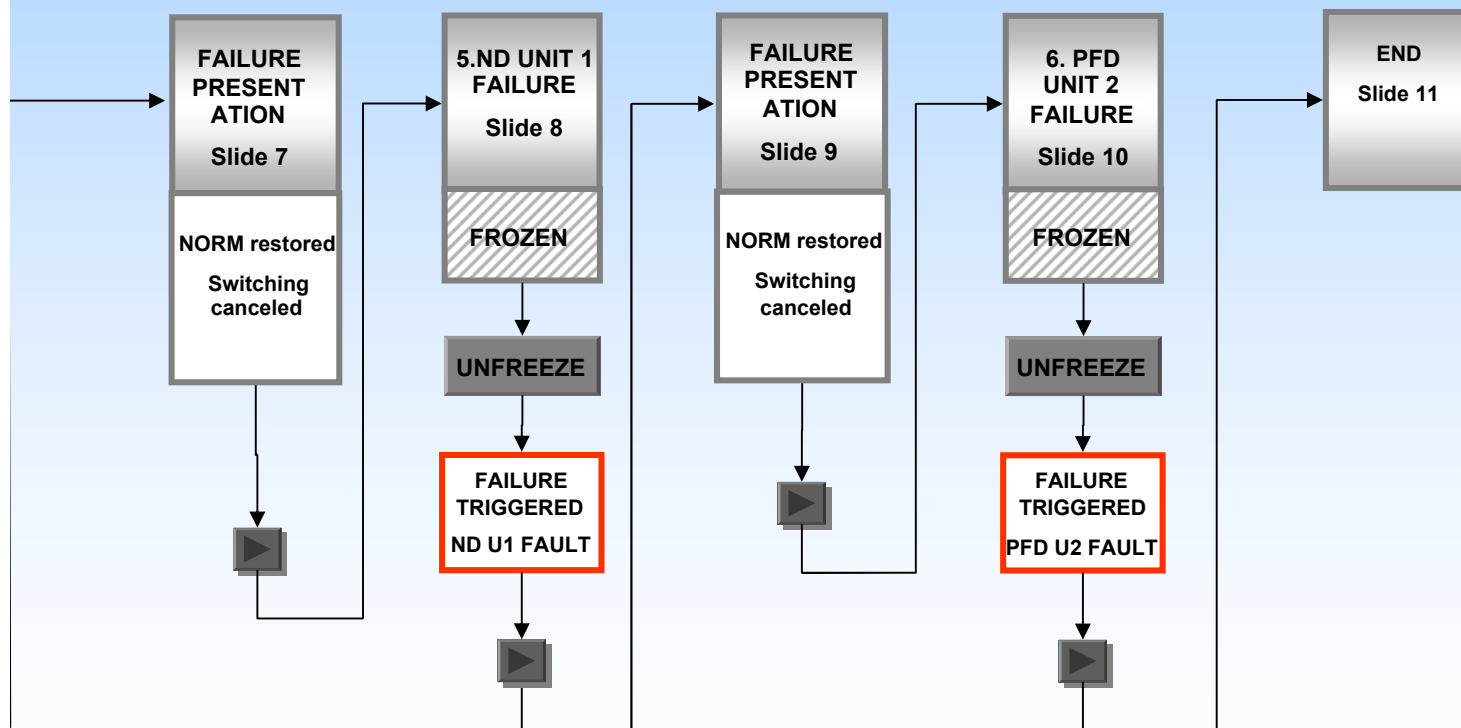

# LR – ELEV REDUNDANCY LOST

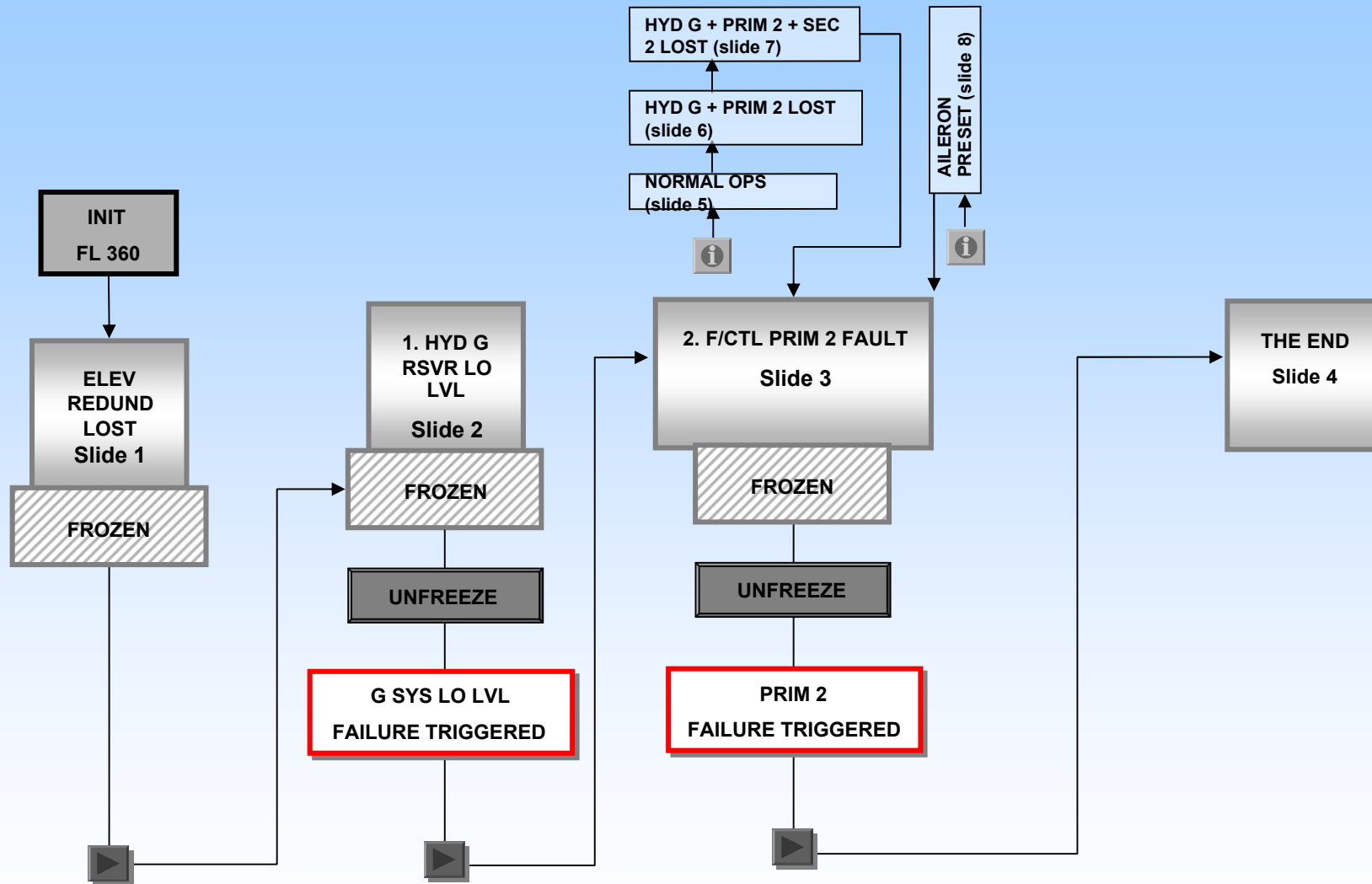



# LR A330 - ELEC EMER CONFIG DYNAMIC CHART

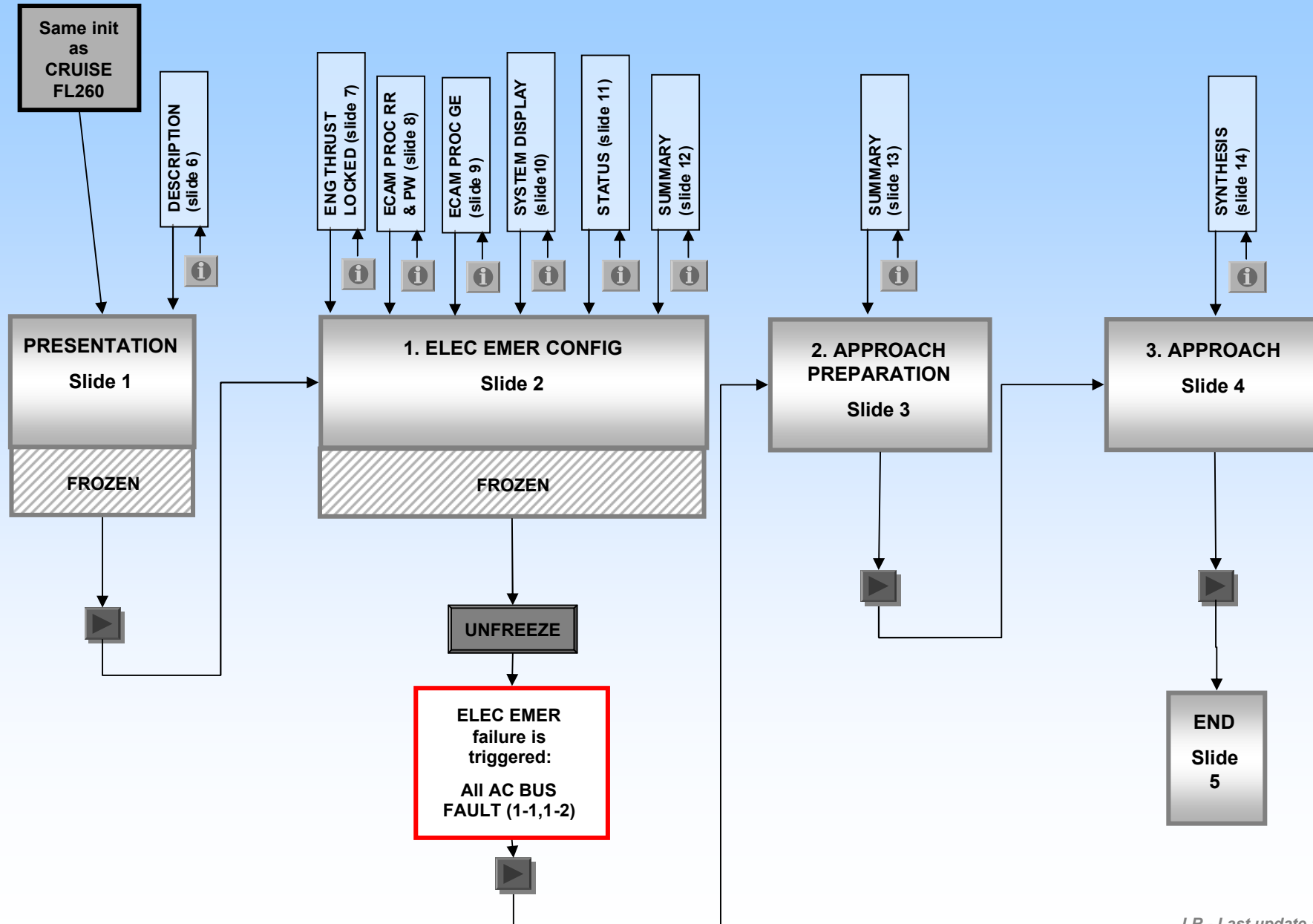

# LR A340 - ELEC EMER CONFIG DYNAMIC CHART

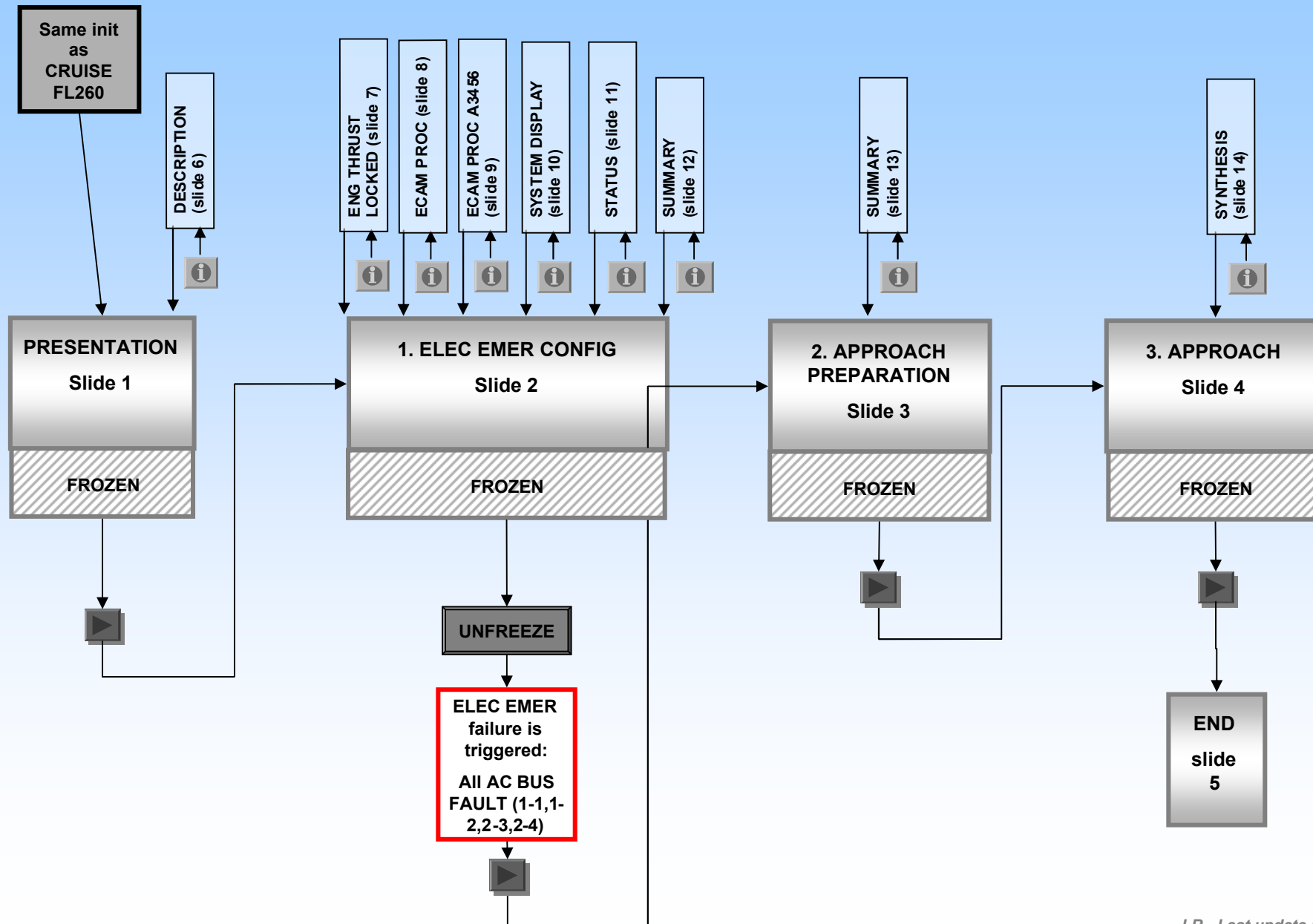

# LR - EMERGENCY DESCENT DYNAMIC CHART

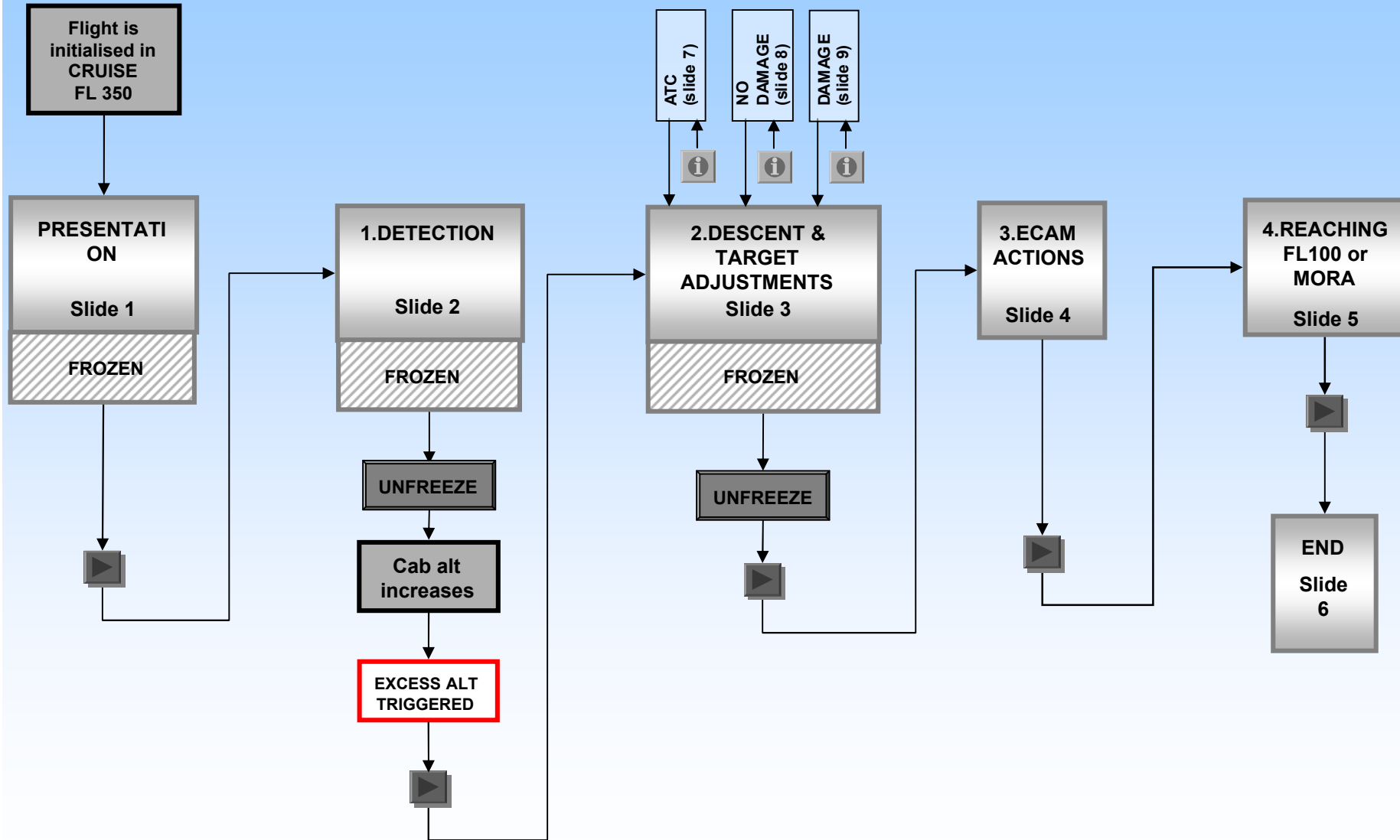

# LR - ENG FAIL IN CRZ DRIFT DOWN DAMAGE

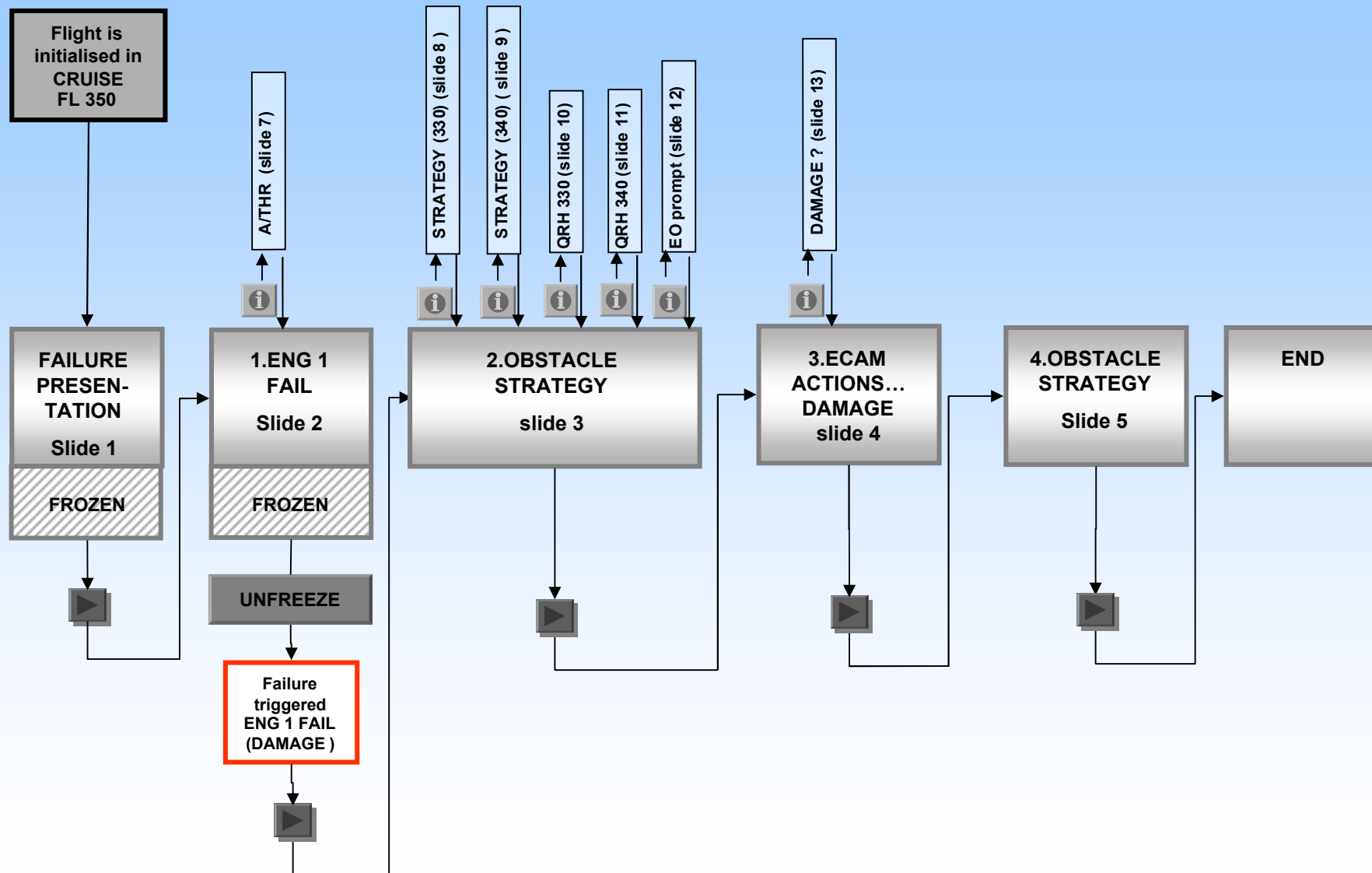

# LR - ENG FAIL IN CRZ STD NO DAMAGE

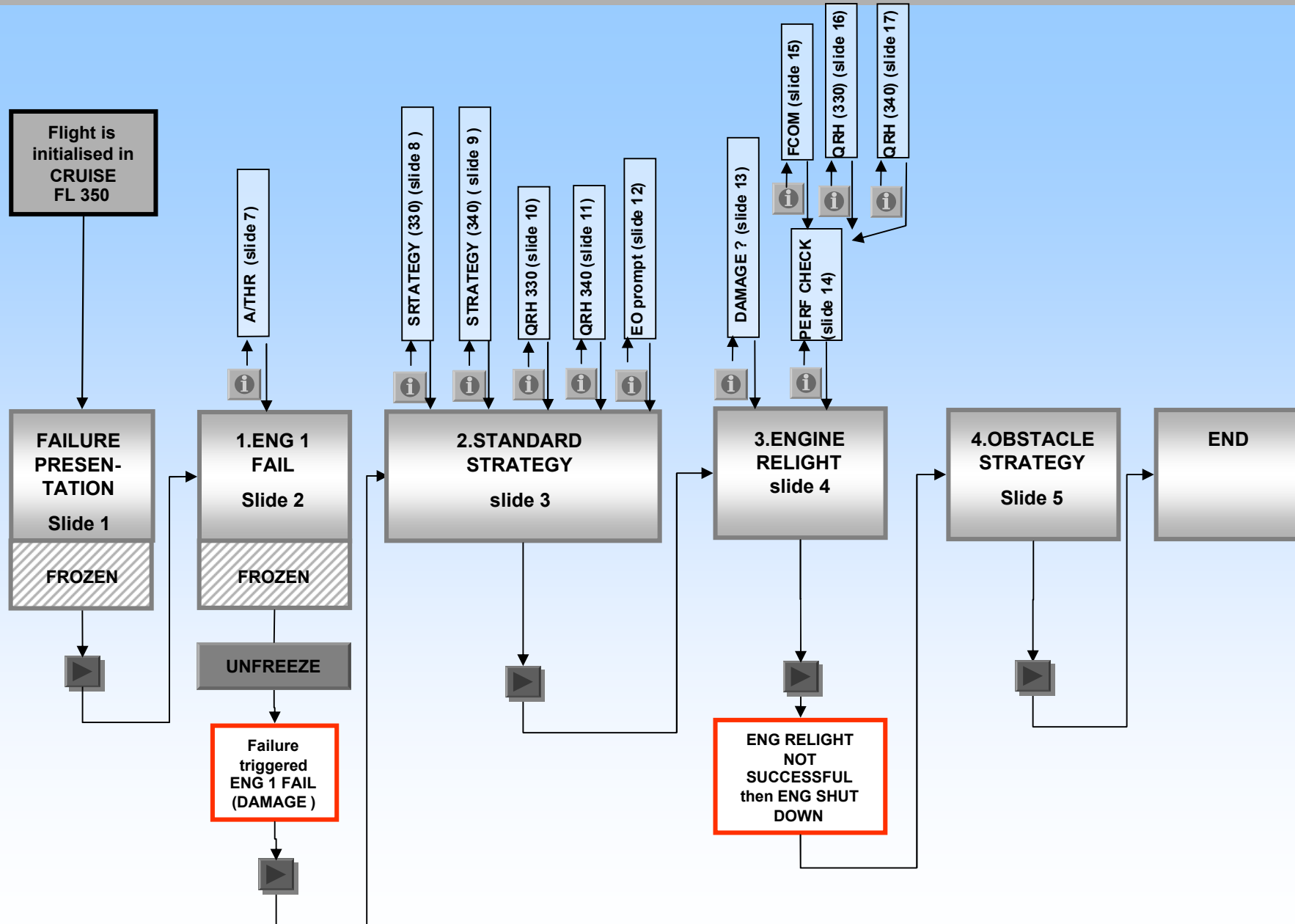

# LR - ENGINE START FAULT

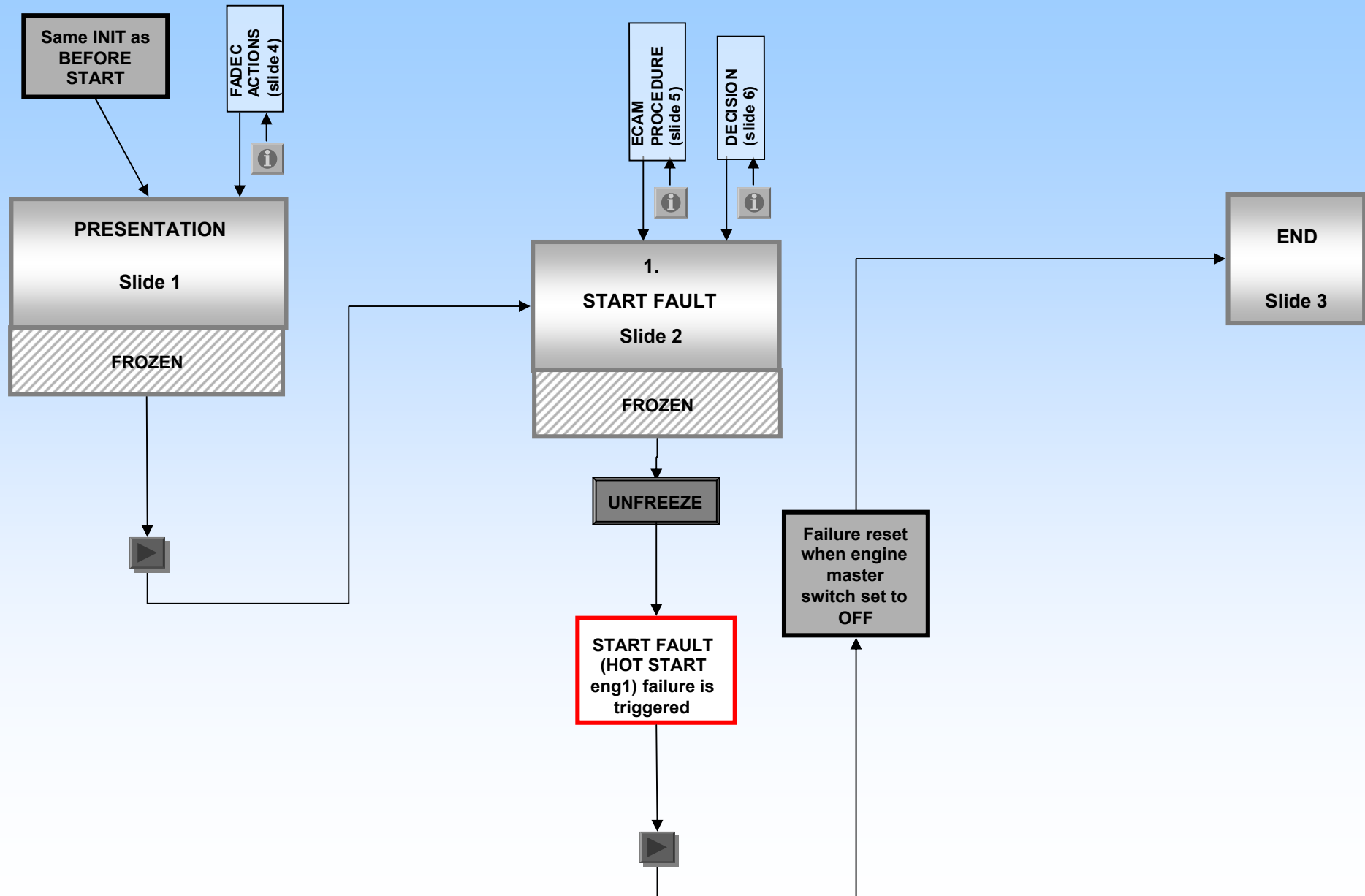

# ENG FAIL AFTER T/O - DAMAGE

ENG 1 FAILURE (A330)  
ENG 2 FAILURE (A340)

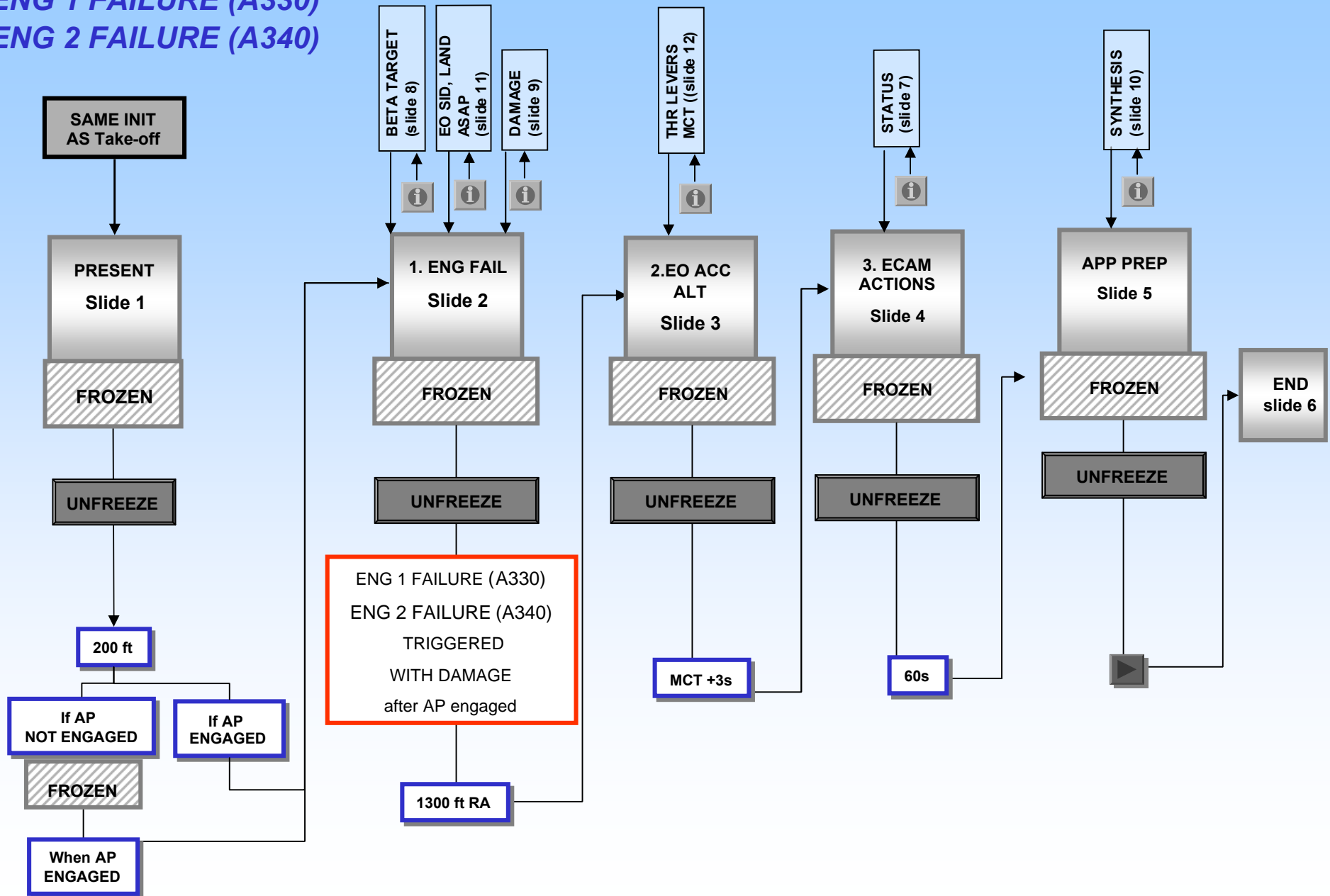

# ENG FAIL AFTER T/O - NO DAMAGE

ENG 2 FAILURE (A330)  
ENG 3 FAILURE (A340)

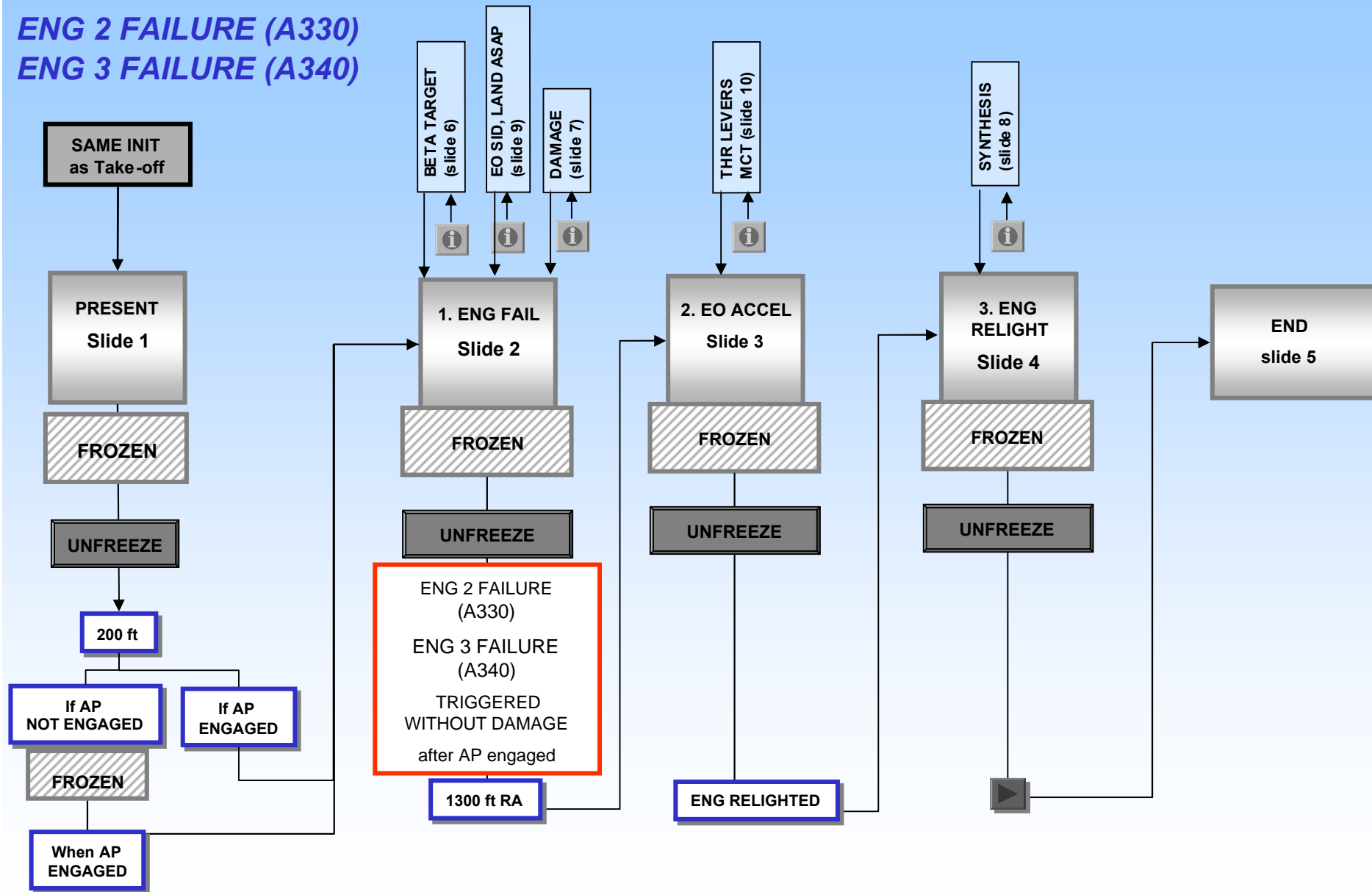



# LR – FM FAULT

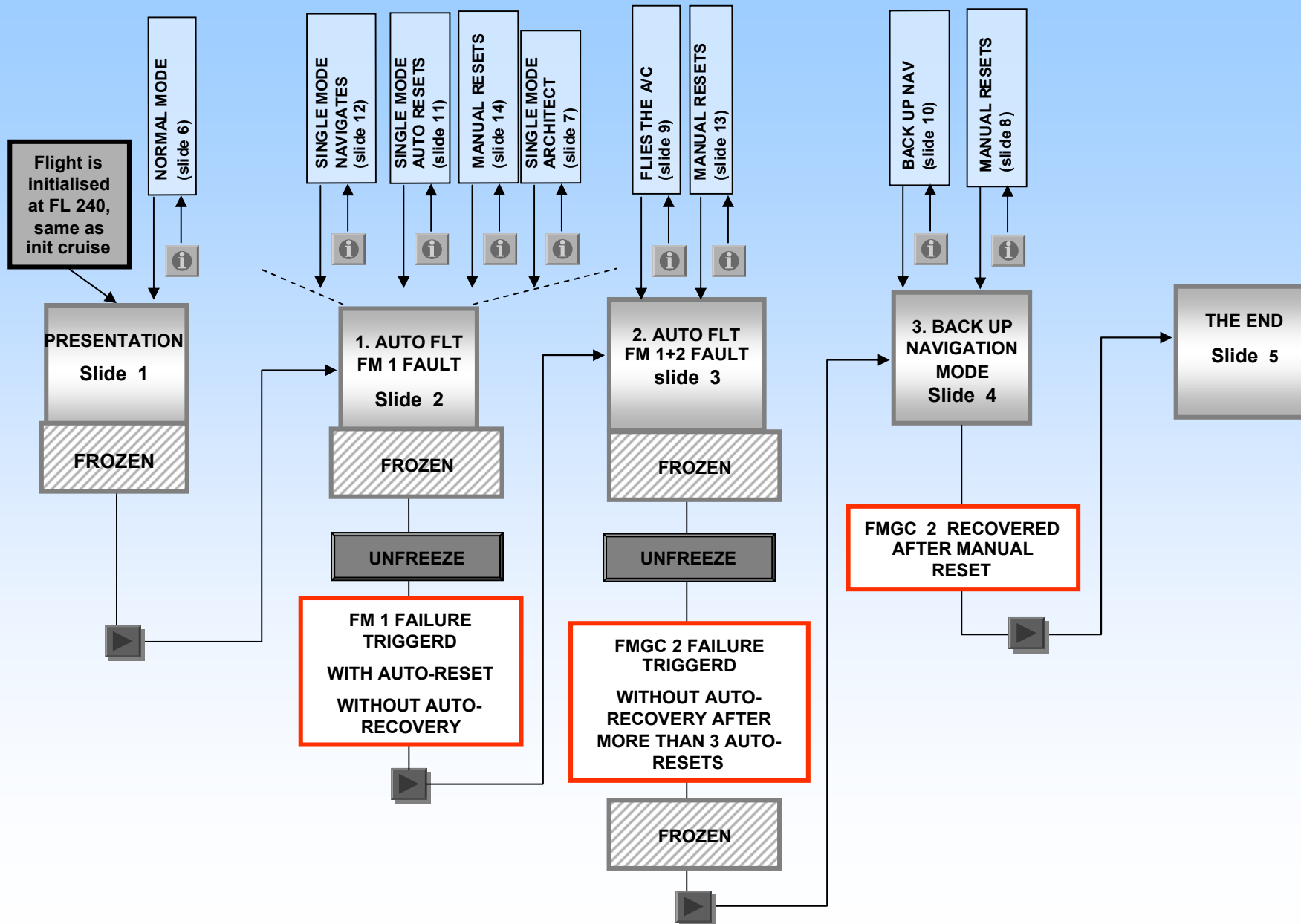

# LR - FLAPS LOCKED DYNAMIC CHART

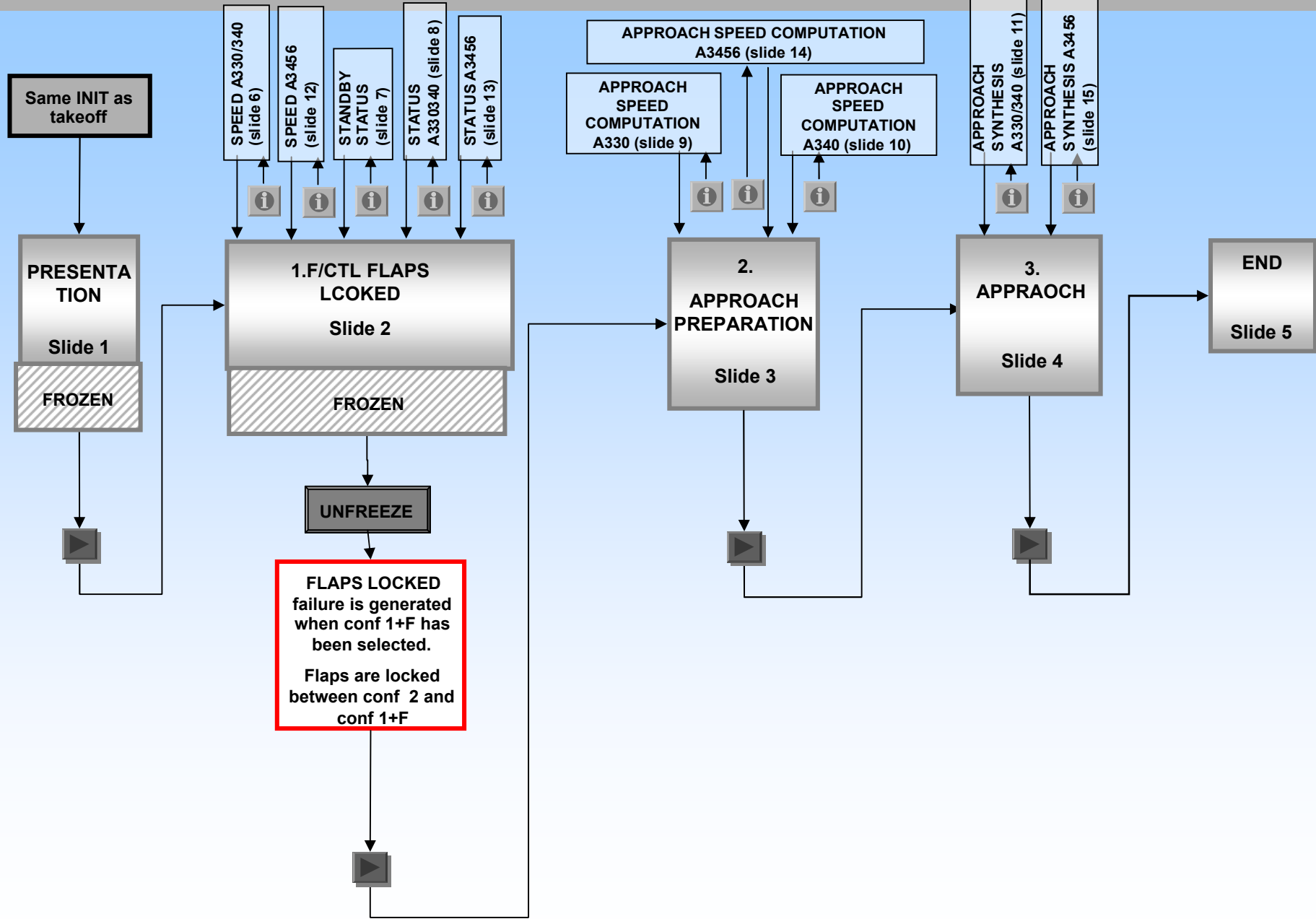

# LR - FUEL IMBALANCE / FUEL LEAK

Temporary note :  
see highlight

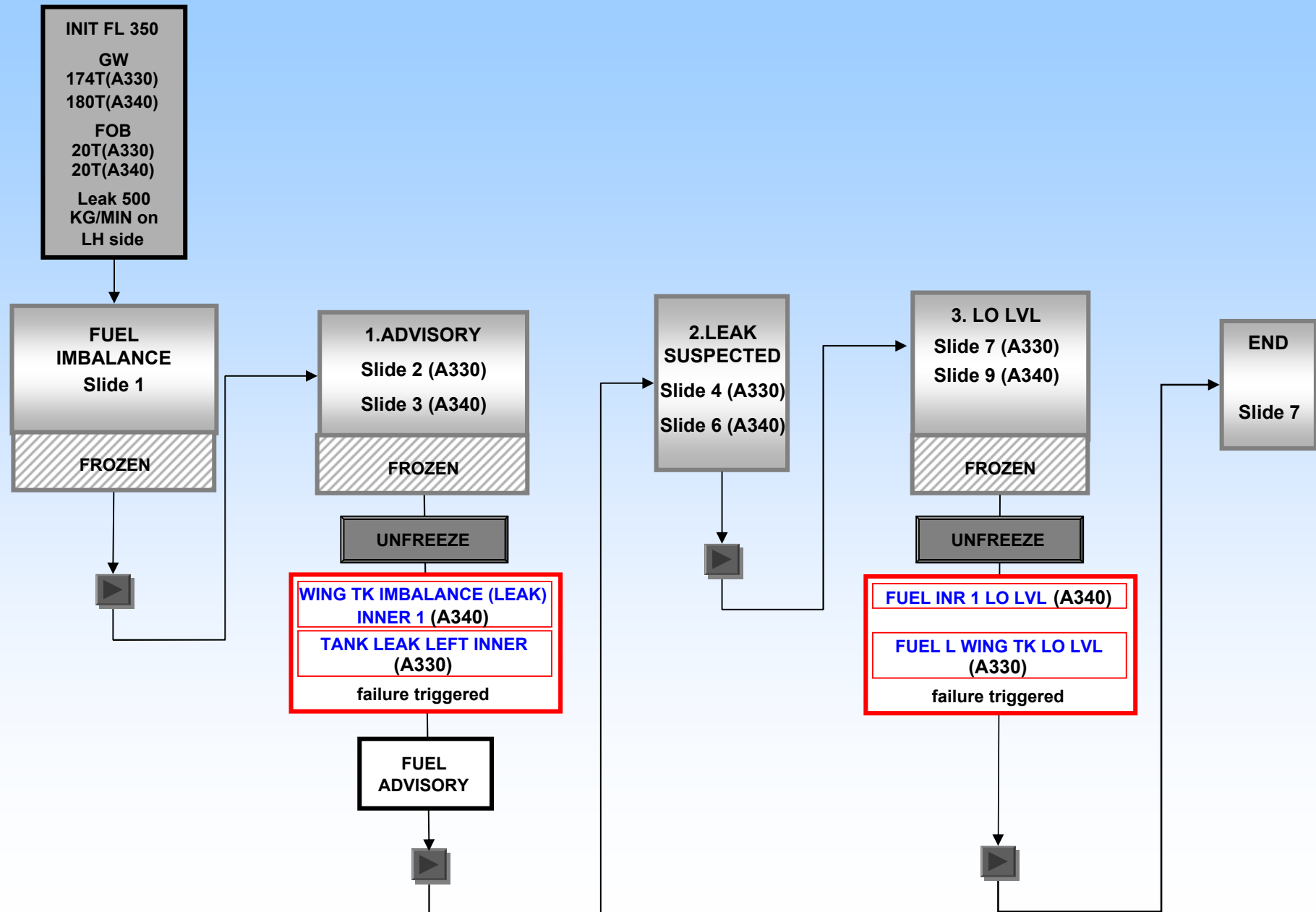

# LR - IR DISCREPANCY

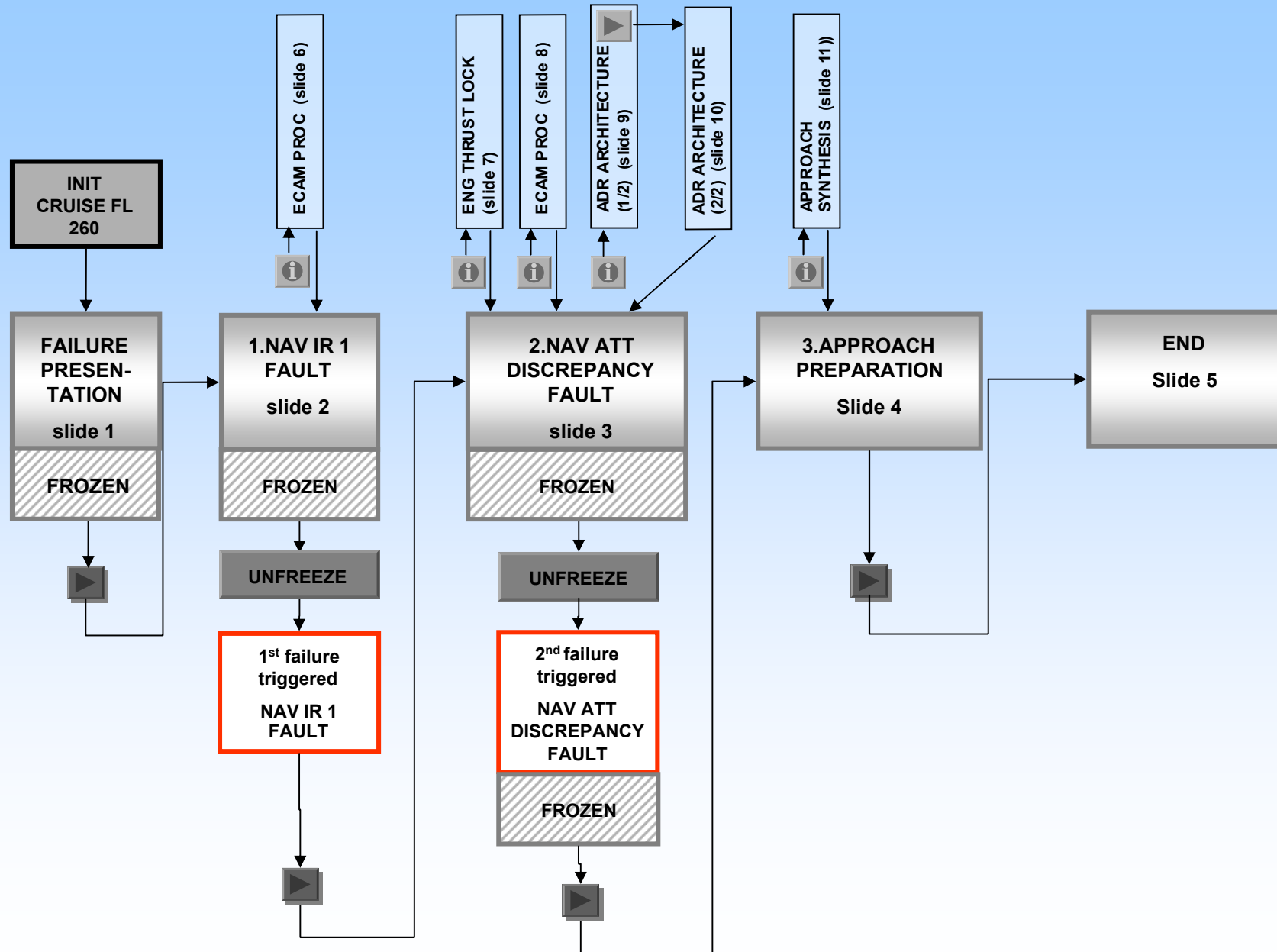

# LR - SLATS FAULT DYNAMIC CHART

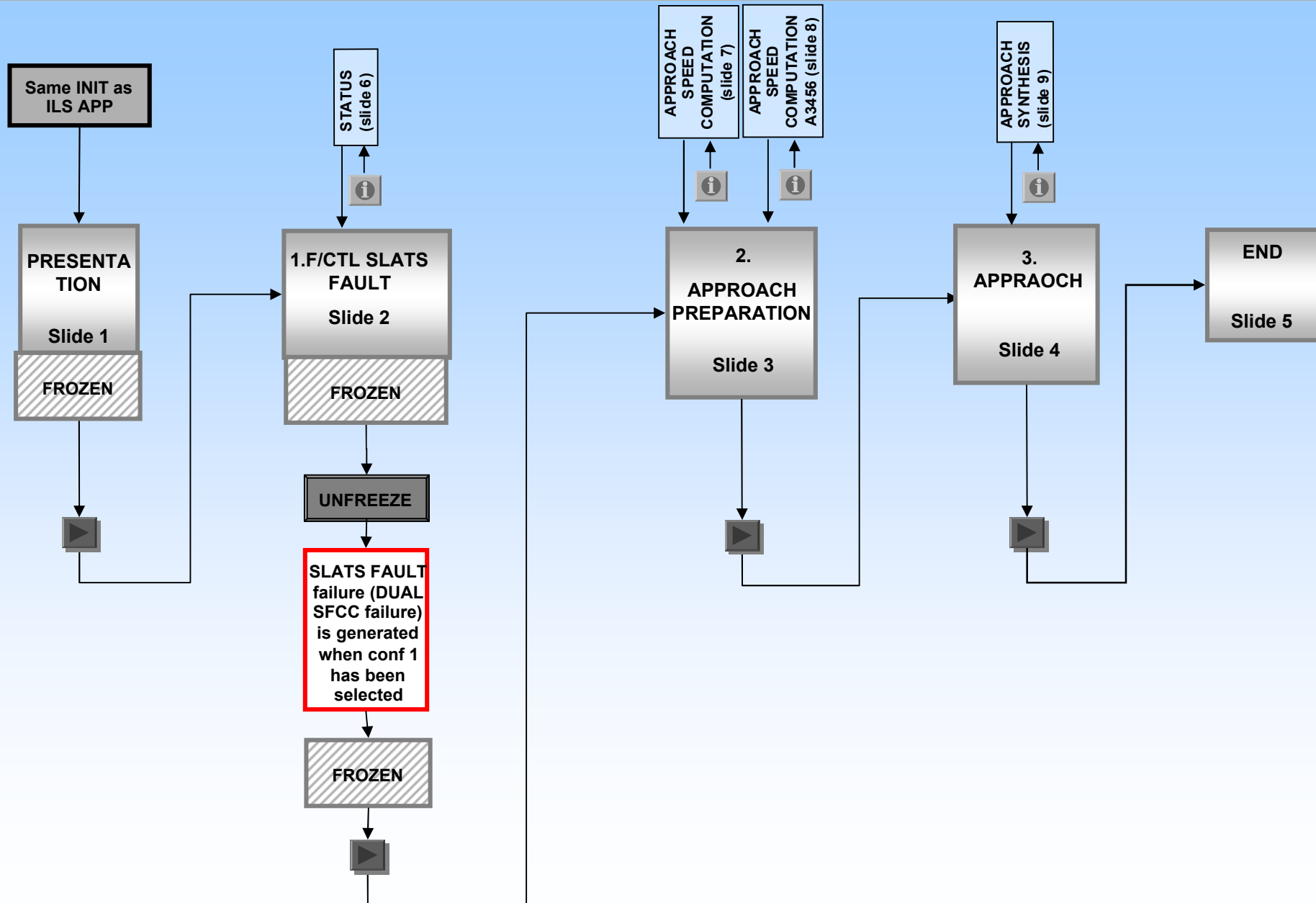

# LR - SMOKE DYNAMIC CHART

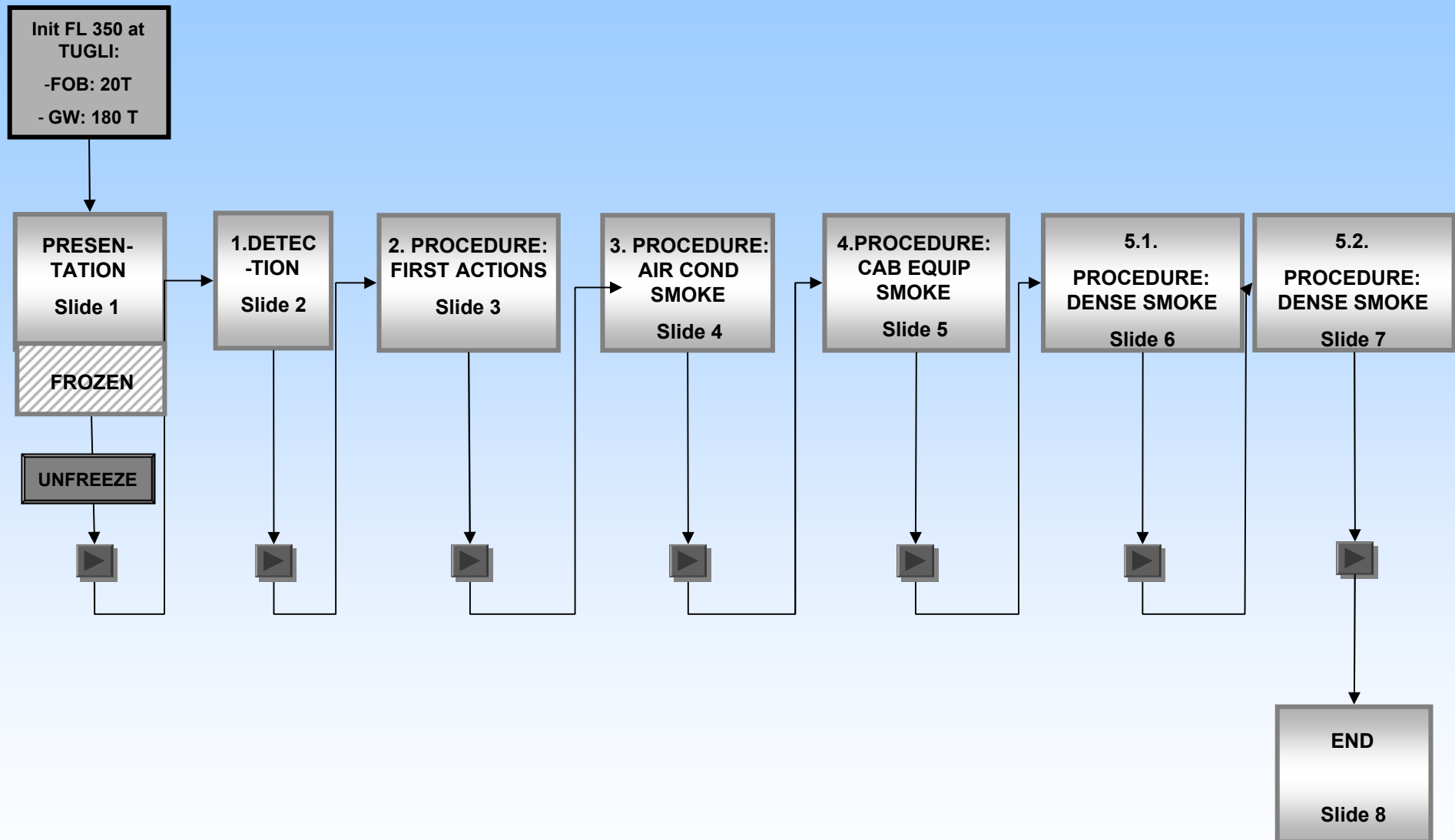

# LR - UNRELIABLE SPEED INDICATION DYNAMIC CHART

## PITOT PROBES BLOCKED

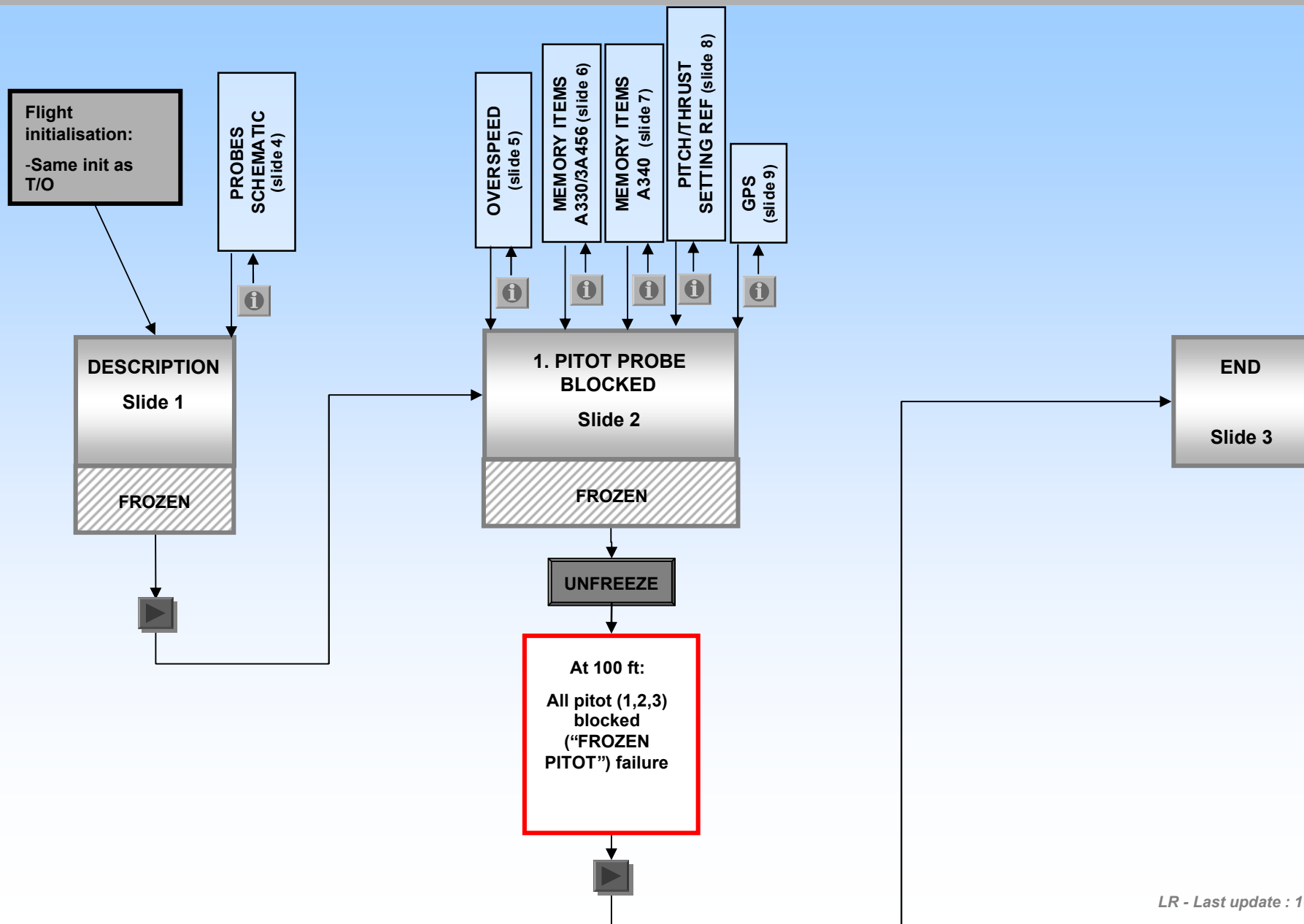

# LR - UNRELIABLE SPEED INDICATION DYNAMIC CHART

## STATIC PROBES BLOCKED

