

23.00 CONTENTS

23.10 RADIO COMMUNICATION

- GENERAL 1
- VHF/HF/SELCAL 2
- RADIO TUNING 3

23.20 INTERCOMMUNICATION SYSTEMS

- GENERAL 1
- CONTROLS 5
- INTERPHONE SYSTEMS 8
- CALL SYSTEMS 12
- PASSENGER ADDRESS 16
- EMER EVAC ◀ 18
- LANDSCAPE CAMERA ◀ 20

R **23.22 EMERGENCY COCKPIT ALERTING SYSTEM ◀**

- R - CABIN TO COCKPIT ALERT 1
- R - COCKPIT TO CABIN ALERT 2

23.30 COCKPIT VOICE RECORDER

- DESCRIPTION 1
- CONTROLS AND INDICATORS ON OVERHEAD PANEL 2

23.35 EMERGENCY LOCATOR TRANSMITTER CONTROL

- PANEL ◀ 1

23.40 ACARS ◀

- GENERAL 1
- COCKPIT ARRANGEMENT 2
- OPERATION MODES 3
- ACARS FUNCTIONS 4

23.45 SATCOM ◀

- GENERAL 1

23.50 WARNINGS AND CAUTIONS

- DESCRIPTION 1

23.60 ELECTRICAL SUPPLY

GENERAL

The communications system comprises the following subsystems:

- VHF / HF transceivers
- Radio tuning systems (Radio Management Panels)
- Audio integrating system (Audio Management Unit, Audio Control Panels)

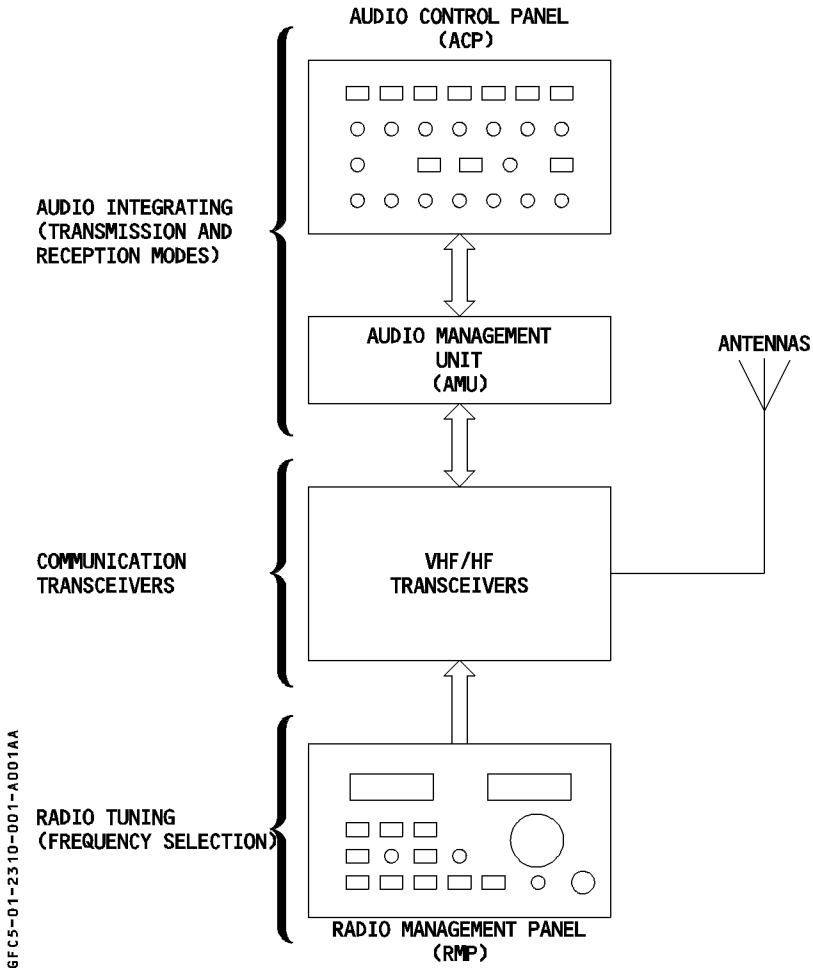

6FC5-01-2310-001-A001AA

**VHF / HF / SELCAL**

Each transceiver may be tuned by any of the three Radio Management Panels (RMPs). Selection of VHF / HF system for transmitting is made through the ACP via the AMU. Each system is connected to the RMPs, for frequency selection, and to the AMU.

– **VHF**

Three identical VHF communication systems are installed. Each system has a transceiver in the avionics compartment, and an antenna on the fuselage. Only VHF 1 is supplied in EMER ELEC CONFIG. It ranges from 118.0 to 136.975 MHZ. The VHF has an alarm to indicate that the microphone is stuck (\ll).

If a microphone is in the emission position for more than 30 seconds, an interrupted tone sounds for 5 seconds, and the emission is turned off. To reactivate the emission, the crew releases the push-to-talk button and presses it again.

– **HF**

Two identical HF communication systems are installed. Each system has a transceiver in the avionics compartment, one tuner and one common antenna located in the vertical stabilizer. Only HF 1 is supplied in EMER ELEC CONFIG. Its ranges is from 2.8 to 24.0 MHZ.

It is lost when LAND RECOVERY is selected ON.

– **SELCAL (Selective Calling)**

Upon receiving a call code corresponding to that of the aircraft, the SELCAL system aurally and visually advises the flight crew that a ground station is calling the aircraft.

The aural signal is inhibited during takeoff and landing.

R

RADIO TUNING**DESCRIPTION**

Identical RMPs :

- Give the flight crew control of all radio communication systems (VHF and HF frequency control).
- Back up to FMGCs for controlling radio navigation systems (Refer to 1.34)

Two RMPs are on the center pedestal and the third on the overhead panel.

Each RMP can control any VHF or HF transceiver. RMP1 and 2 are connected directly to all VHF and HF transceivers, whereas RMP3 is connected to them via RMP1 and 2. RMPs are connected together so that each RMP is updated to the selections made on other RMPs.

Only RMP1 functions in EMER ELEC CONFIG.

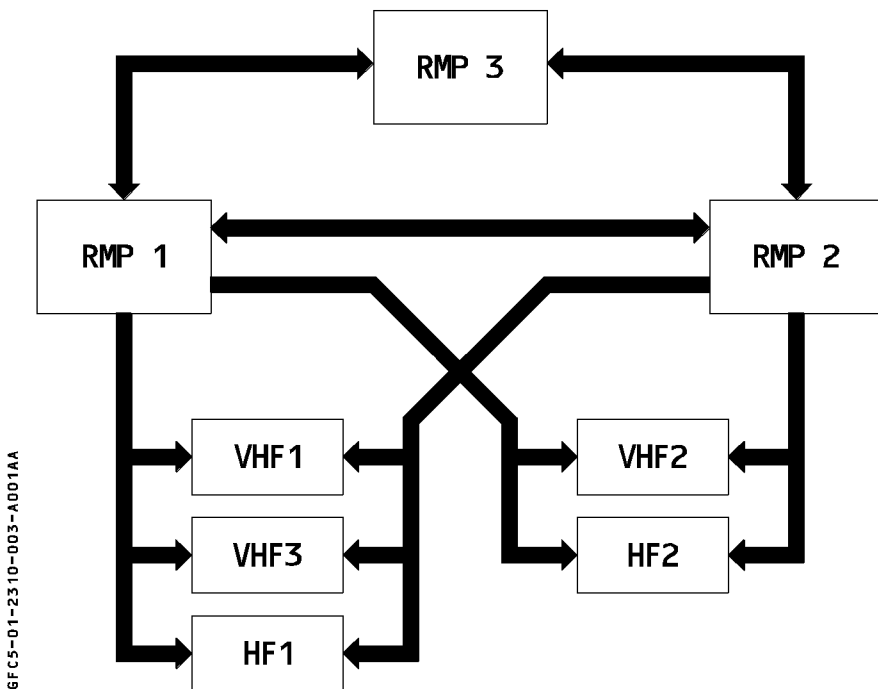

If two RMPs fail, the remaining one controls all the VHF and HF transceivers.

If ACARS is installed, do not use VHF 3 for voice communication ◁.

RADIO MANAGEMENT PANEL

R

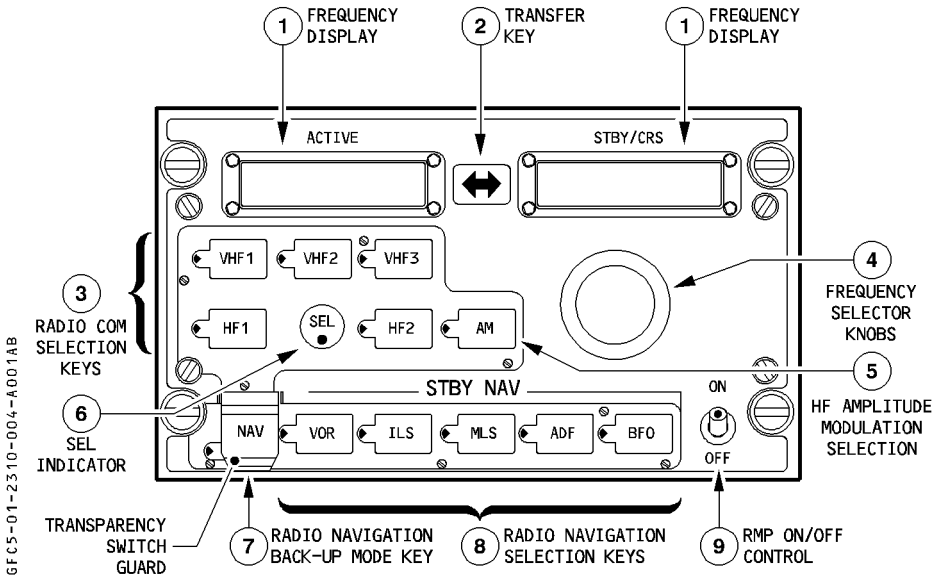
**① Frequency displays**

- The ACTIVE display window shows the active frequency of the selected radio, which is identified by a green light on the selection key.
 - The STBY/CRS (standby / course display) display window shows a standby frequency that the pilot can activate by pressing the transfer key or change by rotating the tuning knobs.
- For a description of the CRS function (see 1.34).

② Transfer key

Pressing this key moves the active frequency to the standby window and the standby frequency to the active window.
This tunes the selected receiver to the new active frequency.

③ Radio comm. selection keys

When the pilot presses one of these keys :

- The ACTIVE window displays the frequency set on that radio.
- The STBY/CRS window displays the selected frequency or course.
- The selected key displays a green monitor light.

 AIRBUS TRAINING A330 SIMULATOR FLIGHT CREW OPERATING MANUAL	COMMUNICATIONS	1.23.10	P 5
	RADIO COMMUNICATION	SEQ 001	REV 03

④ Frequency selector knobs

Selects STBY frequency or CRS.
 Inner knob controls decimal values and outer knob the whole values.

⑤ AM pb sw

Operative only if an HF transceiver has been selected.
 Controls the selection of the AM mode for HF transceivers.
 By default the SSB (Single Side Band) mode is selected.
 Green monitor light illuminates.

⑥ SEL indicator

When a transceiver normally associated with a RMP is tuned by another RMP:

- VHF1 tuned by RMP2 or 3,
- VHF2 tuned by RMP1 or 3,
- VHF3, HF1, HF2 tuned by RMP1 or 2

the SEL indicator illuminates white on both RMPs.

⑦ NAV pb sw (transparent switchguard)

When depressed radio navigation selection is in back up mode. Radio Communication selection is not affected. (Refer to 1.34 chapter).

⑧ Radio navigation selection keys

When depressed, green monitor light illuminates.
 (Refer to 1.34).

⑨ ON / OFF sw

Controls the power supply of the RMP.

Note : When RMP1 or 2 is OFF, RMP3 is still able to control VHF / HF transceivers through them.



GENERAL

Intercommunication is divided into two main systems:

- the audio management system.
- the cabin intercommunication data system.

AUDIO MANAGEMENT SYSTEM

The audio management system allows the flight crew to use :

- all the radio communication and radio navigation facilities installed on the aircraft in transmission and reception mode.
- the interphone systems
- the call systems
- the passenger address system

The audio management system includes:

- an audio management unit (AMU)
- three audio control panels (ACPs)
- sockets at each pilot's station
 - headset jack, boomset connector and hand microphone connector for pilot, copilot, and third occupant
 - headset jack for the fourth occupant
- one interphone jack socket at the ground power receptacle
- boomsets for pilot, copilot, and third occupant, and three hand microphones
- three cockpit oxygen mask microphones
- one radio press to talk switch on each sidestick
- one SELCAL code selection panel
- two cockpit loudspeakers with separate volume controls
- an audio switching facility

If audio channel 1 or 2 fails due to a failure either in an ACP or corresponding AMU, the crew can use the AUDIO SWITCHING selector to select the third audio channel.

GF CS-01-2320-002-A001AB

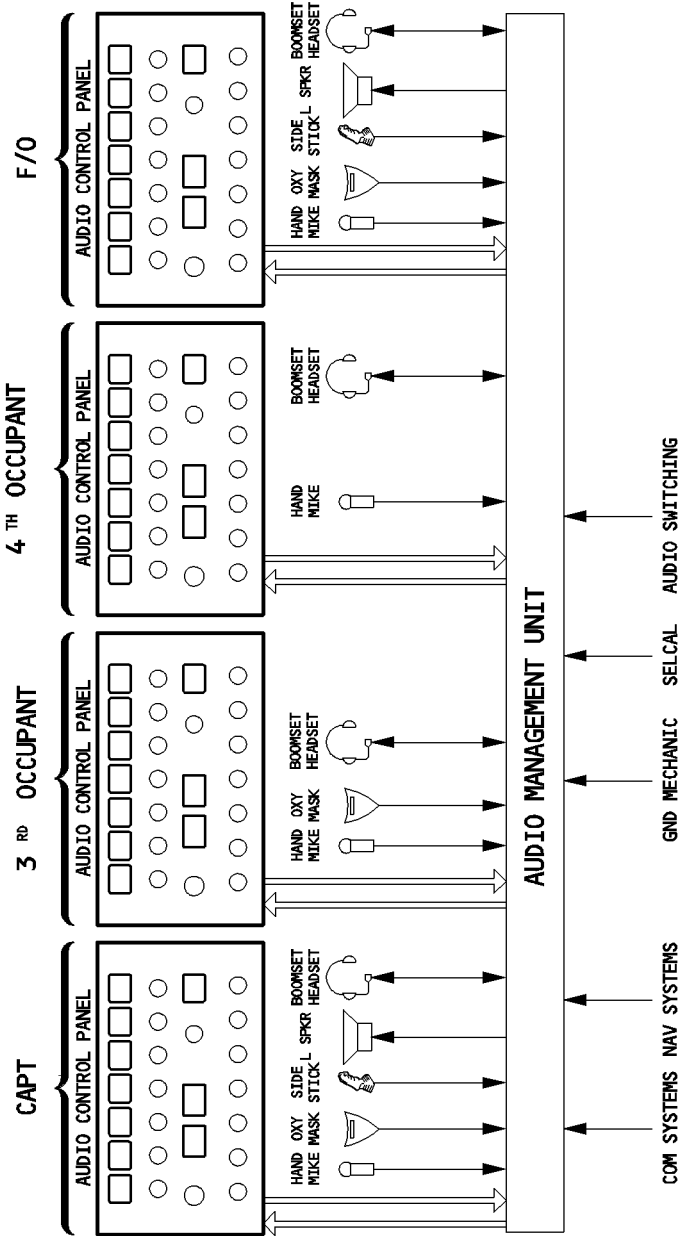

COMPONENTS LOCATION

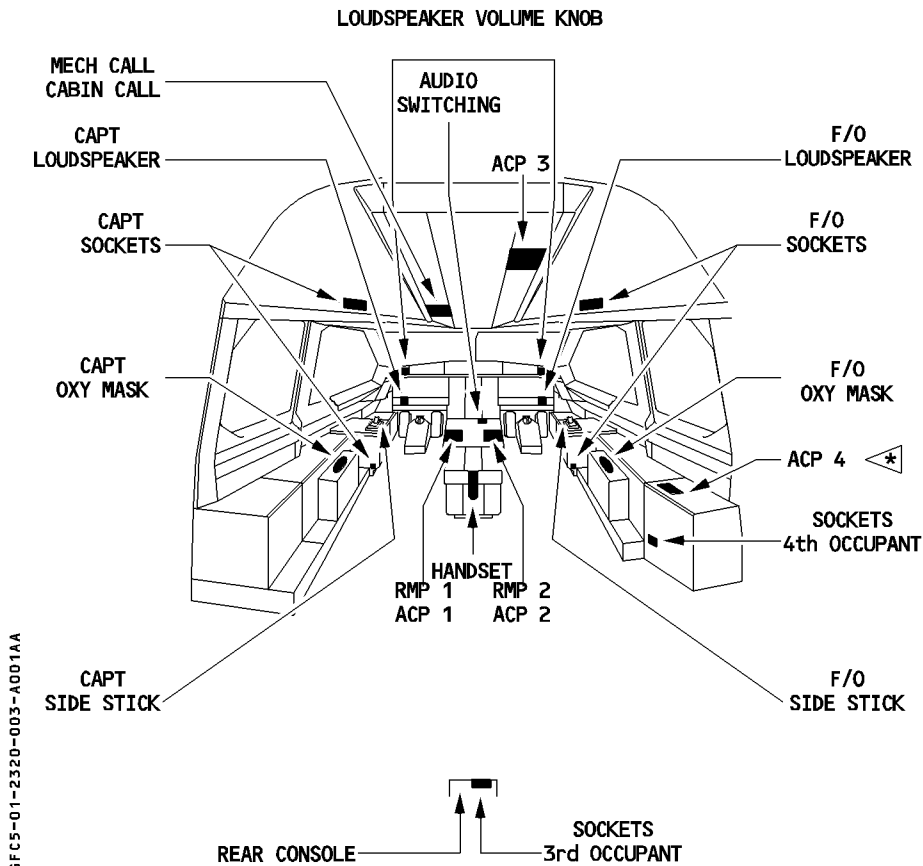

6FC5-01-2320-003-A001AA

CABIN INTERCOMMUNICATION DATA SYSTEM

The Cabin Intercommunication Data System (CIDS) provides signal transmission, controls and processes signals for the following cabin systems :

- cabin and service interphone
- passenger address
- passenger signs
- reading light
- general cabin illumination
- emergency evacuation signalling
- lavatory smoke indication
- passenger entertainment music and video

The CIDS has the following main components:

- two CIDS directors connected in parallel, one active and the other in standby.
- forward attendant panel for control of the cabin systems.
- programming and test module that allows the system to be reprogrammed after changes are made in the cabin configuration.
- attendant stations (FWD, MID, EXIT, AFT).

FOR INFO

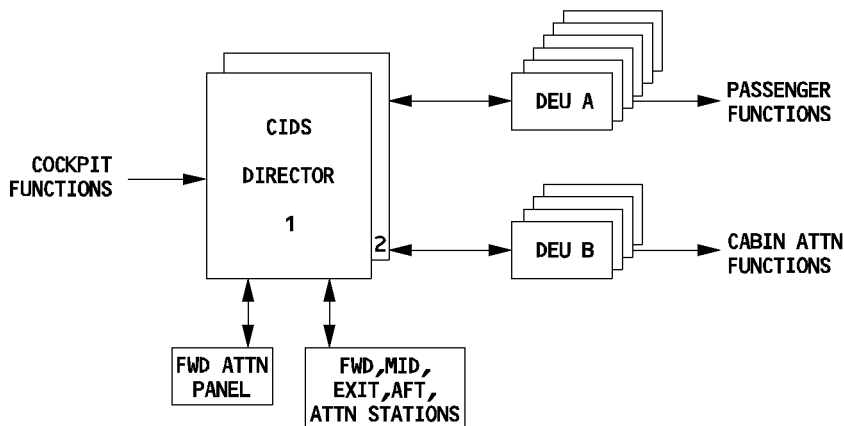

Decoder/Encoder Units (DEUs) are linked to the two directors.

- *Type A units (for passengers): installed in three rows (left, center, right).*

The loudspeakers, lighted signs, call buttons, call lights and general illumination ballast units are divided into small groups each connected to a type A DEU.

- *Type B units (for attendants) are installed on each cabin side. The area call panels, attendant handsets, slide and door pressure sensors, and attendant indicator panels are connected to type B DEUs.*



CONTROLS

AUDIO CONTROL PANEL

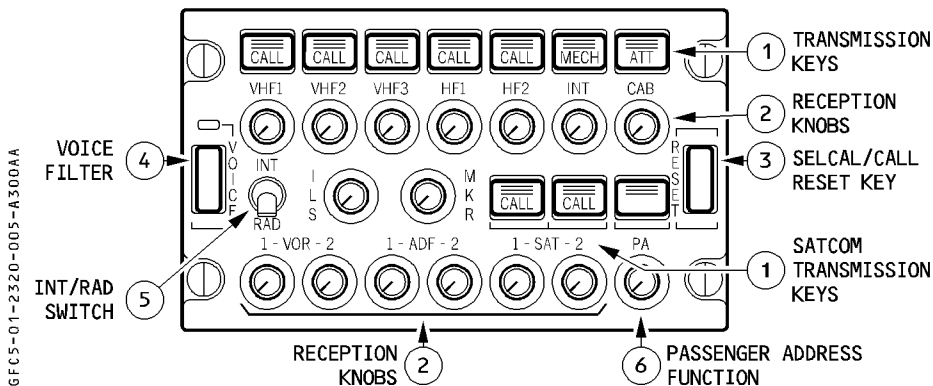

① Transmission keys

- Pressed** : The associated channel is selected for transmission.
The three green lines come on.
The pilot deselects the channel by pressing the pushbutton again, or by selecting another channel.
- CALL It** : The legend flashes amber (and buzzer sounds) when the SELCAL system detects a call.
- MECH It** : The legend flashes amber (and buzzer sounds) for a call from the nose gear bay. The MECH light goes off after 60 seconds, if it is not reset.
- ATT It** : The legend flashes amber (and buzzer sounds) for a call from a cabin attendant. The ATT light goes off after 60 seconds, if it is not reset.
- SAT CALL It** : The legend flashes amber when the SATCOM system detects a call.
The three green lines flash during the establishment of air to ground calls, or when SATCOM calls are on hold.
After call establishment, the three green lines remain steady.

② Reception knobs

- Pressing and releasing the knob (knob out) selects the associated audio reception channel and the integral white light comes on.
- Rotating the knob adjusts the volume.
- The ANN LT sel controls the brightness.
- Pressing the knob (knob stays in) disconnects the associated audio reception channel.

R Note : For reception of DME audio navigation signals associated to an ILS or MLS
R station, the LS pushbutton on the FCU must also be selected.

③ RESET key

Pressing this key extinguishes CALL, MECH and ATT lights and cancels the buzzers.

④ ON VOICE key

This key allows the flight crew to inhibit the audio navigation signals (VOR, ADF). Pressing this key filters out ident signals and turns on the green ON light.

⑤ INT / RAD sw

This switch operates as a Push-to-Talk switch for boom or oxygen mask mike.

INT : Boom and mask mikes transmit on interphone regardless of which transmission key is selected. For reception on interphone, the crew member must have INT selected (INT reception knob out).

Neutral : Reception is normal. Boomset and mask mikes do not transmit.

RAD : Boom and mask mikes transmit on the radio selected on the (press and hold) audio control panel.

⑥ Passenger adress (PA) function

PA transmission key and reception knob.
(Refer to 1.23.20)

SIDE STICK RADIO SELECTOR

6FC5-01-2320-006-1001A

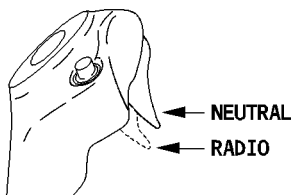

This selector has the same function as the INT / RAD switch on the ACP.

NEUTRAL (spring-loaded) : Boom and mask mikes are dead. Reception is normal.

RADIO (aft position) : Boom and mask mikes transmit through the equipment selected by the transmission key on the ACP.

Note : If RADIO is selected on the side stick when the INT/RAD switch is on INT, the radio function has priority over the interphone function.



LOUDSPEAKER VOLUME KNOB

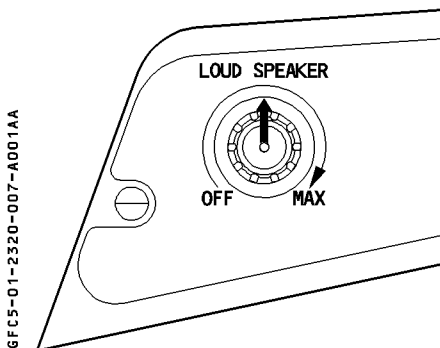

This knob adjusts the volume of the loudspeaker for radio communication.

OFF : Loudspeaker does not respond the signals from the aircraft's radio equipment.

Clockwise rotation : Loudspeaker broadcasts signal from the aircraft's radio equipment at increasing volume.

Note : This knob does not control the loudness of aural alert and voice message.

AUDIO SWITCHING

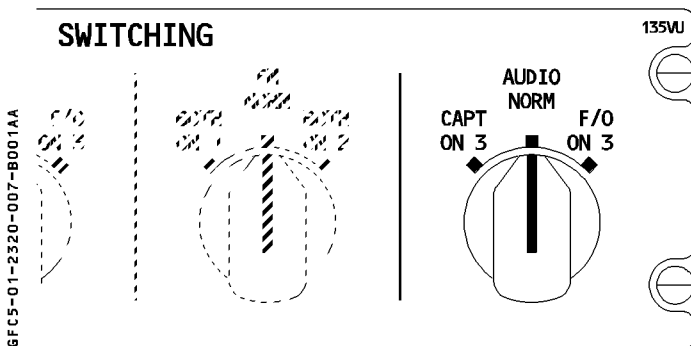

The crew can switch to the third audio channel if ACP1 or ACP2 fails.

When the crew does this, it takes away the third occupant's access to the acoustic equipment.

NORM : Each crew member uses his dedicated communication equipment.

CAPT ON 3 : The pilot uses his acoustic equipment and the third occupant's ACP.

F/O ON 3 : The copilot uses his acoustic equipment and the third occupant's ACP.

INTERPHONE SYSTEMS

FLIGHT INTERPHONE SYSTEM

This system allows the flight crew to communicate among themselves and, through a jack on the external power panel, with the ground mechanic.

EXTERNAL POWER PANEL

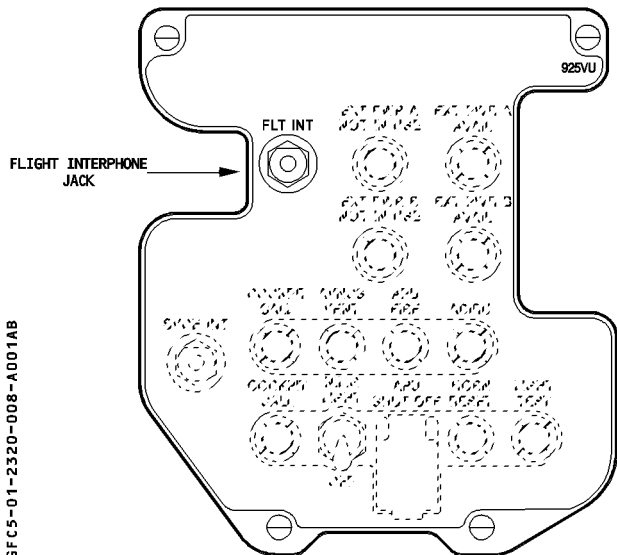

COCKPIT OPERATION FOR GROUND MECHANIC COMMUNICATION

	MECH TRANSMISSION KEY ON ACP	INT RECEPTION KNOB ON ACP	INT/RAD SW ON ACP	PUSH TO TALK ON HANDMIKE
BOOMSET OR OXYGEN MASK	PRESSED	OUT	INT OR RAD (maintained)	
HANDMIKE	PRESSED	OUT		PRESSED



CABIN INTERPHONE SYSTEM

The system provides communication and call facilities between:

- flight crew and attendant stations
- two attendant stations

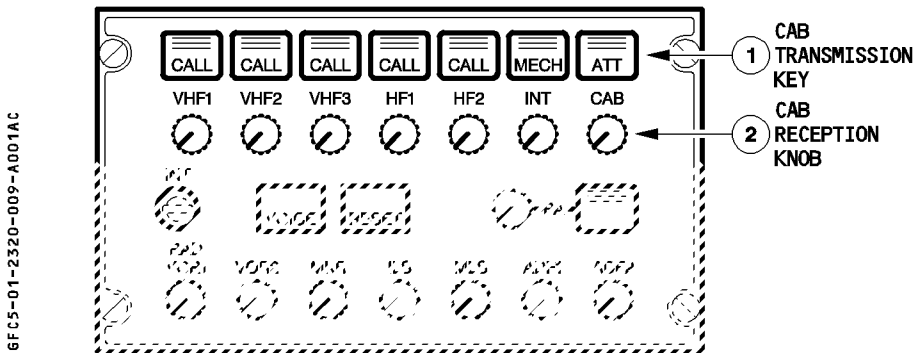

① CAB transmission key

Depressed : Three green lines come on.

Boomset, mask mikes and hand mike may be used for cabin interphone.

② CAB reception knob

Depressed and released : The integrated white light comes on.
(knob out) Audio signal from cabin is received.
Rotate knob to adjust volume.

Depressed : The white light goes off.
(knob in) Cabin interphone is disconnected.

COCKPIT OPERATION

	CAB TRANSMISSION KEY ON ACP	CAB RECEPTION KNOB ON ACP	INT/RAD SW ON ACP	PUSH TO TALK ON HANDMIKE
BOOMSET OR OXYGEN MASK	DEPRESSED	OUT	RAD	–
HANDMIKE	DEPRESSED	OUT	–	PRESSED

SERVICE INTERPHONE SYSTEM

The system provides communication between:

- the flight crew and the service interphone jacks
- the flight attendant stations and the service interphone jacks
- the different service interphone jacks

The service interphone system comprises:

- thirteen interphone jacks
- an OVRD switch located on the overhead panel

The audio lines from the interphone jacks are connected to both CIDS directors.

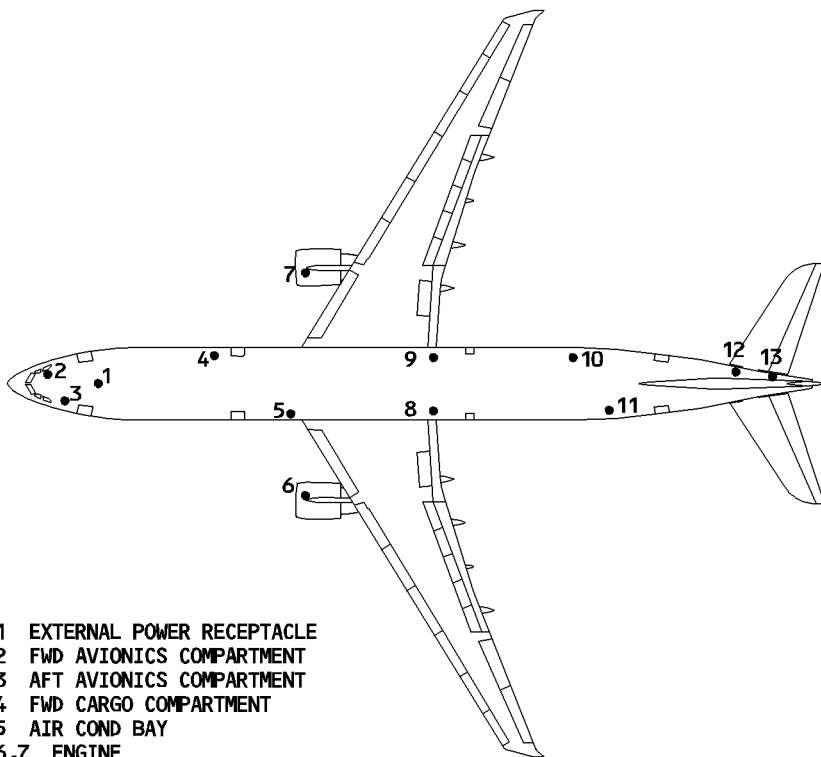
LOCATION OF INTERPHONE JACKS

- 1 EXTERNAL POWER RECEPTACLE
- 2 FWD AVIONICS COMPARTMENT
- 3 AFT AVIONICS COMPARTMENT
- 4 FWD CARGO COMPARTMENT
- 5 AIR COND BAY
- 6,7 ENGINE
- 8,9 HYDRAULIC COMPARTMENT
- 10 AFT CARGO COMPARTMENT
- 11 DIGITAL FLIGHT DATA RECORDER
- 12 TRIM ACTUATOR
- 13 APU COMPARTMENT



CONTROLS AND INDICATORS ON OVERHEAD PANEL

For maintenance purpose only.

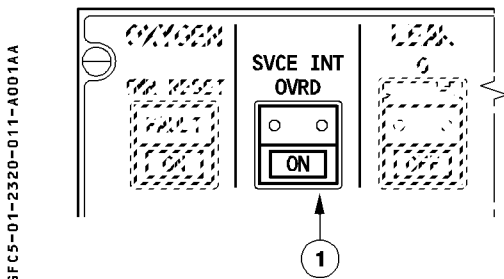

① SVCE INT OVRD pb sw

Auto : Ground personnel can communicate with the flight crew by means of the service interphone jacks after the aircraft has landed. The landing gear must be compressed.

ON : Communication is possible when the landing gear is not compressed. The ON light is white.

COCKPIT OPERATION

	CAB TRANSMISSION KEY ON ACP	CAB RECEPTION KNOB ON ACP	INT/RAD SW ON ACP	PUSH TO TALK ON HANDMIKE	SVCE INT OVRD PB SW
BOOMSET	PRESSED	OUT	RAD (maintained)		ON IF L/G NOT COMPRESSED
HANDMIKE	PRESSED	OUT		PRESSED	

CALL SYSTEMS**GROUND MECHANIC CALL**

The system allows the flight crew and the ground mechanics to communicate each other.

CONTROLS AND INDICATORS ON OVERHEAD PANEL

6FC5-01-2330-012-A001AB

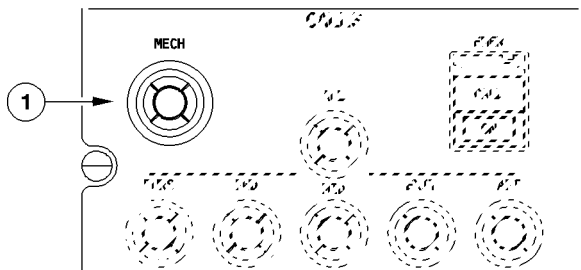
**① MECH pb**

- R Pressed (and held) : COCKPIT CALL lights up blue on the external power panel.
 R An external horn sounds.
 R Released : COCKPIT CALL remains lighted.
 R The ground mechanic can extinguish it by pressing the
 R HORN RESET pushbutton on the external power panel. The
 R external horn stops sounding.

Note : To communicate with the ground mechanic, the flight crew must select the MECH key and the INT reception knob on the ACP.



CONTROLS AND INDICATORS ON EXTERNAL POWER PANEL

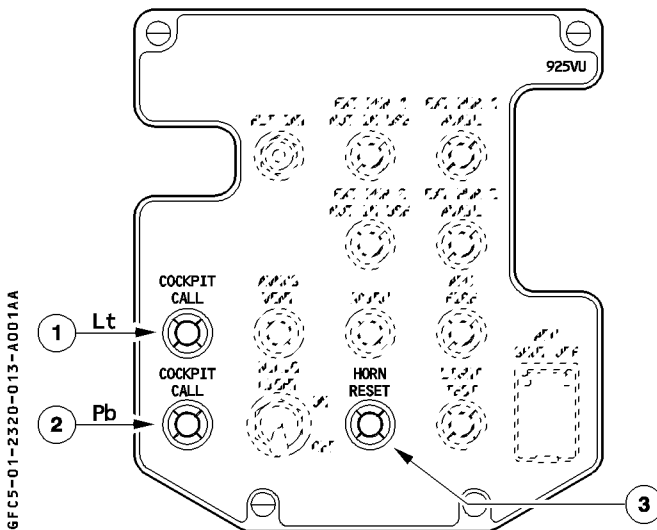

① COCKPIT CALL Lt

The blue light appears when cockpit calls the ground mechanic. An external horn also sounds.

② COCKPIT CALL Pb

Pressed : This calls the cockpit.

The MECH lights flash amber on the ACPs and a buzzer sounds.

Released : The MECH lights go out after 60 seconds if they are not reset on the ACPs. The buzzer stops.

③ HORN RESET pb

Pressed : The COCKPIT CALL light goes out.

The external horn stops sounding.

CABIN CALL SYSTEM

This system is for communication between the cockpit and the cabin.

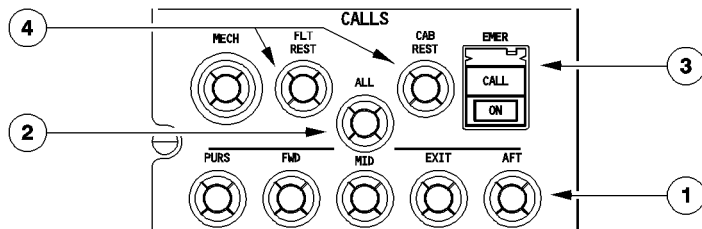
CALL FROM THE COCKPIT**① PURS / FWD / MID / EXIT / AFT pb**

Pressed : A steady pink light comes on at the corresponding area call panel. CAPTAIN CALL appears at the corresponding attendant indication panel and a green light comes on. A high-low chime sounds through corresponding loudspeaker.

② ALL pb

Pressed : All stations respond as above simultaneously. CALL ALL CAPT appears on the attendant indication panels.

③ EMER pb sw (guarded)

ON : Pink light illuminates at all area control panels. CALL PRIO CAPT message appears at all attendant indication panel and a red light comes on. High-low chime (repeated 3 times) sounds through all loudspeakers.

ATT amber lights flash on Audio Control Panels.

ON It : This light flashes white for an emergency call from the cockpit to the cabin.

CALL It : This light flashes amber for an emergency call from the cockpit or cabin.

For an emergency call from the cabin to the cockpit:

- The white ON light and amber CALL light flash.
- The amber ATT lights flash on the audio control panels
- Three long buzzers sound in the cockpit.

The system reset when the attendant hangs up the relevant handset.

④ FLT REST/CAB REST pb

These pushbuttons are not active on A330.

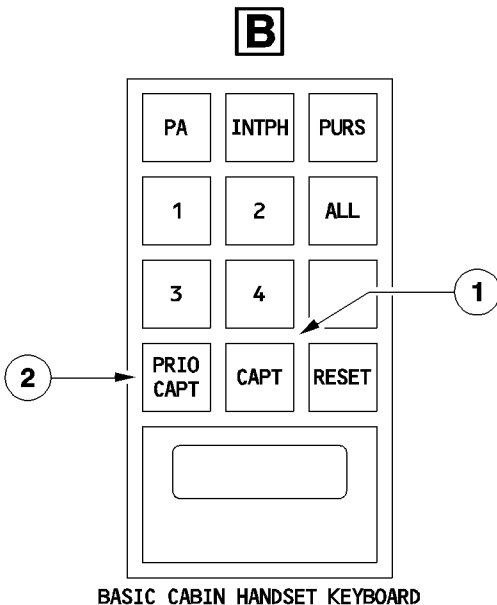
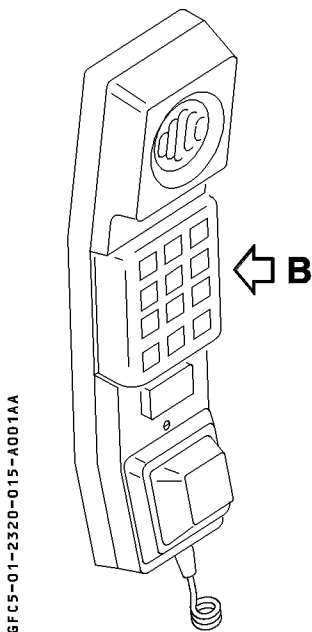
CALL FROM THE CABIN**① CAPT key**

Pressed : In the cockpit, the "ATT" lights up on the ACP and a buzzer sounds.
 In the cabin, "CAPTAIN" appears at the AIP, where the CAPT button was pressed. The buzzer is inhibited during takeoff and landing.

R

② PRIO CAPT key

Pressed : This key is used for emergency calls. In the cockpit, the "ATT" lights up on the ACP, and three buzzers sound.
 In the cabin, "PRIO CAPTAIN" appears at the AIP, where the PRIO CAPT button was pressed. The buzzer is inhibited during takeoff and landing.

R

PASSENGER ADDRESS

The passenger address system enables cabin announcements to passengers via loudspeakers. It can either be operated from the cockpit (using ACP or handset), or from the cabin (attendant stations).

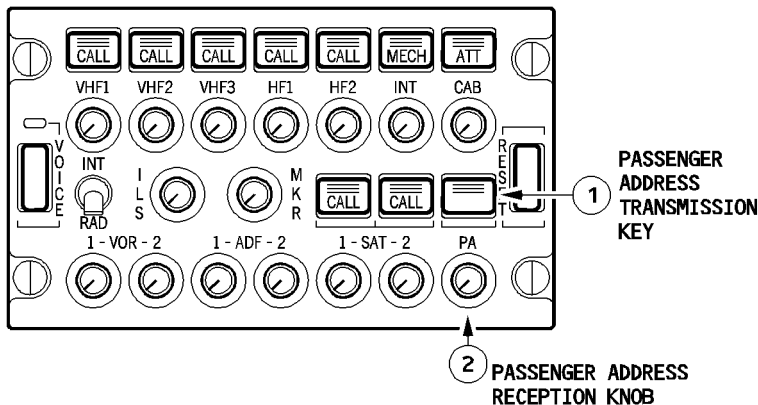

6FC5-01-2320-016-A100AA

① PA transmission key

Pressed and held : The flight crew may use a boom, mask, or hand mike to make an announcement.
Three green lines come on.

Note : The flight crew may use a cockpit handset to make PA announcements without action on the ACPs.

② PA reception knob

Pressed and released (knob out) : The message goes to the loudspeakers and the integral white light comes on.
The flight crew can rotate the knob to adjust the volume.

Pressed (knob in) : The PA system is disconnected.
The white light goes out.



Cockpit handset

R The cockpit handset, located at the bottom of the pedestal, is used for PA announcements.

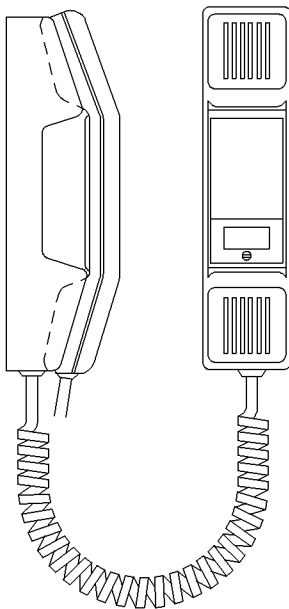

6FC5-01-2320-017-A001AA

**PA from cockpit**

	PA TRANSMISSION KEY ON ACP	PA RECEPTION KNOB ON ACP	PUSH-TO-TALK ON HANDMIKE	PUSH-TO-TALK ON HANDSET
BOOMSET OR OXYGEN MASK	PRESSED (maintained)	OUT	–	–
HANDMIKE	PRESSED (maintained)	OUT	PRESSED	–
HANDSET	–	–	–	PRESSED

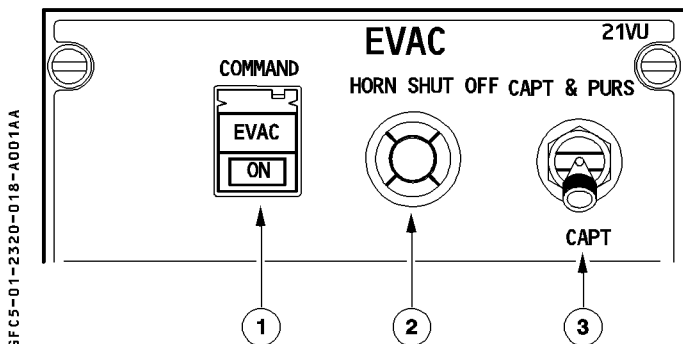
EMER EVAC ()

① COMMAND pb

- ON** :
- In the cockpit : – EVAC light flashes red.
 - In the cabin : – EVAC lights flash at all attendant panels.
 - “EVACUATION ALERT” appears on all attendant indication panels and a red light flashes.
 - Specific evacuation tone sounds.

Off : The alert is stopped.

The EVAC light flashes red when the alert is activated.

② HORN SHUT OFF pb

This button silences the cockpit horn (generated when evacuation is activated from the cabin).

③ CAPT and PURS / CAPT sw

CAPT and PURS : The alert may either be activated from the cockpit or the cabin.

CAPT : The alert may only be activated from the cockpit.

R
R

If one of the cabin EVAC CMD keys is pressed, only the cockpit horn sounds for 3 seconds.



R PURSER STATION

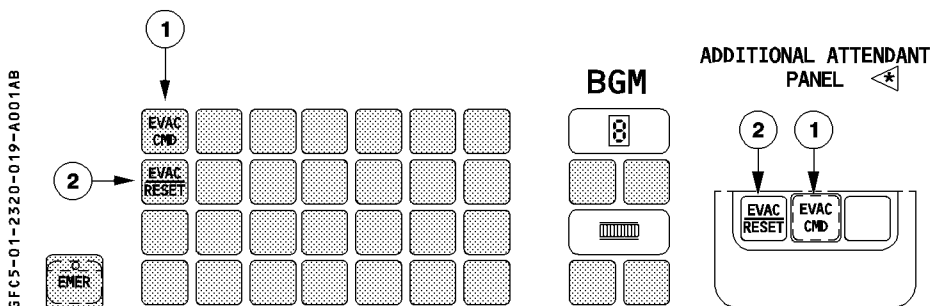

① EVAC CMD key

Pressed momentarily :

In the cockpit, the EVAC light flashes red and a specific horn sounds.

In the cabin, the EVAC RESET lights flash red at all attendant stations, the EVAC CMD light comes on green on forward attendant panel, "EVACUATION ALERT" appears at all the AIPs and a red light flashes, and a specific evacuation tone sounds.

② EVAC RESET key

Pressing momentarily this button silences the evacuation tone.



DESCRIPTION

The Cockpit Voice Recorder is designed to record:

- direct conversations between crew members and all aural warnings in the cockpit,
- communications received and transmitted by radio,
- intercom conversations between crew members,
- announcements transmitted over the passenger address system provided PA reception is selected on third audio control panel.

Only the last 30 minutes of recording are retained.

The CVR system consists of:

- a remote microphone located behind overhead panel,
- a crashproof four track recorder located in the aft section of the aircraft. It is equipped with an Underwater Locating Beacon,
- a control panel located on the overhead panel.

It is automatically energized:

- on ground during the first five minutes following energization of the aircraft electrical network,
- on ground with one engine running,
- in flight

It is automatically stopped five minutes after last engine shutdown.

On ground CVR can be manually energized by pressing GND CTL pb.

CONTROLS AND INDICATOR ON OVERHEAD PANEL**RECORDER**

GFC5-01-2330-002-A001AA

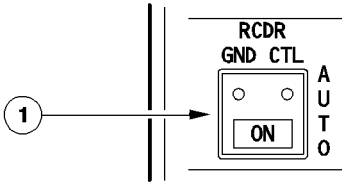
**① GND CTL sw (spring loaded switch)**

ON : The CVR, the digital flight data recorder (DFDR) and QAR ◀ are manually energized.
 The ON light comes on blue.

AUTO : The CVR, DFDR and ◀ QAR are automatically energized according to the logic (see page 1).
 The ON light goes out.

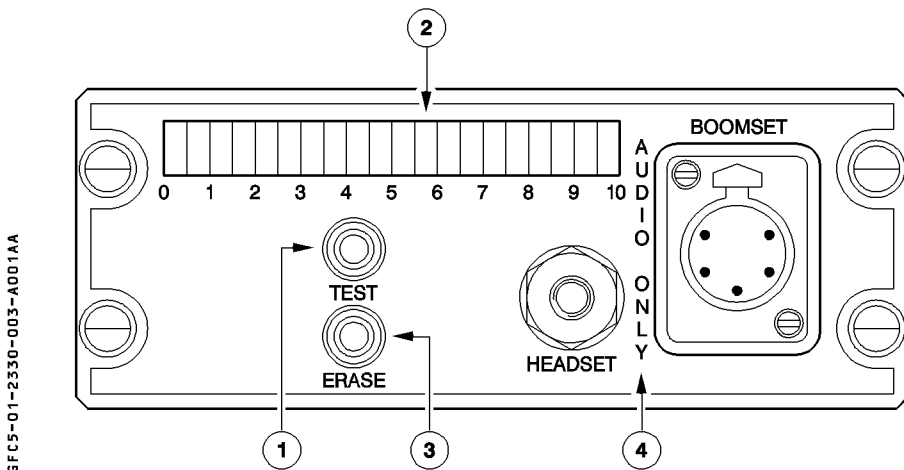
CVR PANEL**① TEST pb**

Pressed : This activates the test, if the CVR is energized.

The result of the test is visible on the test result indicator.

If an acoustic equipment is plugged into the jack, the test will be heard as low frequency signal.

② Test result indicator

The indicator is composed of green and red LEDs.

R The illumination of one or more green LEDs indicates that the test result is good.

③ ERASE pb

Pressed for 2 seconds : : This completely erases the tape, if the aircraft is on ground and the parking brake is ON.

④ Headset and Boomset jacks

When a headset or boomset is plugged into the jack :

- Cockpit sounds, picked up by the microphone, are audible.
- The test tone is audible, when the TEST pushbutton is pressed.
- The erase tone is audible, when the ERASE pushbutton is pressed.

GENERAL

The Satellite Communication (SATCOM) system allows the exchange of information between the aircraft and a Ground Earth Station (GES), via geosynchronous satellites.

R It provides up to six independent channels :

R One channel is used for data transmissions (ACARS). Two or five channels are used for

R voice transmissions (cockpit or cabin voice). The cockpit voice function must be activated,

R in order for it to be available. The cabin telephone system must be installed, to be able to

R use cabin voice function.

The ACARS normally transmits via VHF3. It automatically switches to SATCOM when VHF3 is not available.

The cockpit voice interface is controlled by the Audio Control Panels (ACPs) for call set-up and call termination, and by the MCDU for the call number selection. It allows the crew :

- To initiate air to ground calls and to receive ground to air calls.
- To select the call priority, in case of air to ground calls.
- To use manual dial or pre-recorded phone numbers.

If a SATCOM telephone handset is installed in the cockpit, the crew can set up a call without the use of the MCDU.

SATCOM functions are programmed through the Owner Requirement Table (ORT), according to airline needs.

Due to the highly customized programming, the SATCOM functions may vary for different airlines and are, therefore, not described in detail.

CONTROLS AND INDICATORS**ACP INTERFACE**

Refer to the 1.23.20 description.

MCDU INTERFACE**SATCOM MAIN MENU PAGE**

The crew accesses this page by selecting SAT on the MCDU MAIN page.



- 2L (4L)** : This field displays the SATCOM channel 1 (2) status :
 (Label line) – **READY TO CONNECT** : The channel is ready to support a call.
 – **NOT AVAILABLE** : The channel is not available (failed or not logged).
 – **DIALING** : Cockpit call in progress.
 – **INCOMING CALL** : Advises of an incoming ground to air call.
 – **CONNECTED** : The circuit is connected.
 – **CALL FAILED** : The transmission is interrupted.
- 2L (4L)** : This field displays :
 (Data line) – The title of the selected phone number, in case of an air to ground call.
 – The number, if the **MANUAL DIAL** option is used.
 – **GRND-AIR CALL**, in case of a ground to air call.
- 5R** : This key provides access to the Manual Dial page. This page allows the dialing of a phone number.
- 6L** : This key provides access to the SATCOM STATUS page, which contains LOG ON and channel status information.
- 6R** : This key provides access to the SATCOM DIRECTORY PAGE.

**SATCOM DIRECTORY PAGE**

This page provides access to 4 phone number lists, where phone numbers can be memorized, according to their priority.

6FCS-01-2345-003-A115AA

SATCOM DIRECTORY		
[1L]	<EMERGENCY	[1R]
[2L]	<SAFETY	[2R]
[3L]	<NON-SAFETY	[3R]
[4L]	<PUBLIC	[4R]
[5L]		[5R]
[6L]	<RETURN	[6R]

- 1L : EMERGENCY for Priority 1 - Reserved for emergency and distress phone numbers only.
- 2L : SAFETY for Priority 2 - Reserved for regulatory and flight safety phone numbers only.
- 3L : NON-SAFETY for Priority 3 - Reserved for non flight safety phone numbers.
- 4L : PUBLIC for Priority 4 - Reserved for personal phone numbers.
- 6L : This key is used to return to the SATCOM MAIN MENU page.

SATCOM CATEGORY NUMBERS PAGE

The CATEGORY NUMBERS page provides access to the pre-recorded phone numbers. As an example, the following figure shows the SAFETY CATEGORY NUMBER page.

SATCOM SAFETY 1/3		SAT1/2
1L	*IOR CONTROL	1
	00495218796214	
2L	*CDG ARPT	
	[0098564721336985]	
3L	*HKG ARPT	
	004632189752123	
4L	*ORD ARPT	SORT*
	453356722268	
5L	*ORY ARPT	FIND*
	[004433566213]	[]
6L	<RETURN	

- 1L, 2L, 3L, 4L, 5L : These fields display the phone numbers and their titles. When one of these keys is pressed, the corresponding phone number is dialed. There are two types of numbers :
- Protected : Displayed in green
 - Unprotected : Displayed in blue brackets
- 1R : This field displays the selected SATCOM channel.
- 4R : This function alphabetically sorts the phone numbers within the category, according to title.
- 5R : This function automatically searches for a phone number from the beginning of this category, by entering up to the first three letters of the title into the scratchpad, and by pressing 5R.
- 6L : This key is used to return to the SATCOM DIRECTORY page.



SATCOM MANUAL DIAL PAGE

The MANUAL DIAL PAGE enables the crew to initiate an air to ground call by manually entering a phone number.

6FC5-01-2345-005-A 100AA

SATCOM MANUAL DIAL		
[1L]	PHONE NUMBER	[1R]
[2L]	[0033546454373432]	[2R]
[3L]	SAT 1/2	[3R]
[4L]	↑ PRIORITY ↓	[4R]
[5L]	NON-SAFETY	[5R]
[6L]	<RETURN PRE-SELECT*	[6R]

- 2L (data line) : This field displays the phone number in blue brackets, after having been entered in the scratchpad.
- 4L : This field displays the selected SATCOM channel.
- 5L : This field displays the priority for the manual dial number. The priority can be changed by pressing the slew up or down keys on the MCDU keyboard.
- 6L : This key is used to return to the SATCOM MAIN MENU page.



DESCRIPTION

6FC5-01-2350-001-A110AA

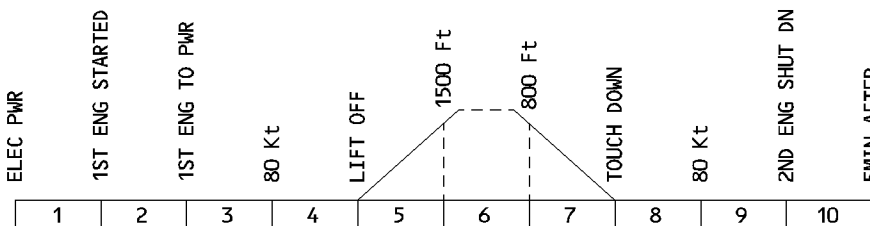

R

E / WD: FAILURE TITLE conditions	AURAL WARNING	MASTER LIGHT	SD PAGE CALLED	LOCAL WARNING	FLT PHASE INHIB		
VHF 1 (2) (3) EMITTING HF 1 (2) EMITTING Transceiver emitting more than 60 seconds	SINGLE CHIME	MASTER CAUT	NIL	NIL	3,4,5 7,8		
CIDS 1 + 2 FAULT Total loss of CIDS							
CIDS PA FAULT Loss of passenger address part							
ACARS 1 (2)(1+2) FAULT ◀	NIL	NIL					
SATCOM FAULT ◀ Telephone and ACARS transmissions are lost.	SINGLE CHIME	MASTER CAUT			NIL	NIL	1 *, 3, 4, 5, 7, 8, 10 *
SATCOM DATA FAULT ◀ ACARS transmissions are lost. Telephone transmissions are still available.							
SATCOM VOICE FAULT ◀ Telephone transmissions are lost, ACARS is still transmitted via SATCOM.							
VHF 3 DATA FAULT ◀							

* SATCOM FAULT message is inhibited in flight phases 1 and 10 when IRS are not aligned.

MEMO DISPLAY

- Displays “SEAT BELTS” and “NO SMOKING” messages in green, when the corresponding sign on the overhead panel is on.
- Displays “AUDIO SWTG” in green, if the AUDIO SWITCHING selector is not on NORM.
- Displays “PA IN USE” (optional) in green, during passenger address operation.
- Displays “VIDEO IN USE” (optional) in green, during video operation in the cabin.
- Displays “CABIN READY” in green (pulses 10 seconds, then steady), when a signal is sent from the cabin crew, and in the takeoff and landing memo.<

In addition, if ACARS is installed, the display shows :

- ACARS VHF3, VOICE in green, flashes continuously, if VHF3 is operating in voice mode and ACARS communication is interrupted.
- ACARS MSG in green, if ACARS has received a message from the ground, and a continuous buzzer sounds.
- ACARS STBY in green, if ACARS communications between the aircraft and the ground are lost.
- ACARS CALL in green, when an uplink message requests voice communication.
- ACARS ALERT in green, when an uplink alert message has been received.

If ATSU is installed, the displays shows :

- VHF3 VOICE in green, flashes for 10 seconds if VHF3 is operating in voice mode.
- HF : VOICE in green, flashes for 10 seconds if both HFs (<) are operating in voice mode.
- GND HF DATA in green, if HF (<) is operating in data mode on ground.

If SATCOM is installed, the display shows “SATCOM ALERT” in green, when a message with a priority level below 4 is received from the ground.



BUS EQUIPMENT LIST

		NORM			EMER ELEC		
		AC	DC	DC BAT	AC ESS	DC ESS	HOT
RADIO COMMUNICATION	VHF1					X	
	VHF2		DC 2				
	VHF3		DC 1				
	HF1				SHED (1)		
	HF2	AC 2					
	RMP1					X	
	RMP2		DC 2				
	RMP3		DC 1				
	CAPT ACP					X	
	F/O ACP					X	
	THIRD ACP		DC 1				
	SELCAL		DC 1				
	FLT INTERPHONE					X	
	CAPT LOUDSPEAKER					X (2)	
F/O LOUDSPEAKER					X (2)		
EXT HORN						HOT 2	
CABIN INTERCOMM DATA SYS	CIDS1		GND/FLT			X	
	CIDS2		GND/FLT			X	
	DEU (A/B)		GND/FLT			X	
COCKPIT VOICE RECORDER	CVR CTL		DC 1				
	CVR				SHED		
ACARS ◀	MV	AC 1					

(1) This supply is lost when LAND RCVR is selected ON.

(2) Normal supply is from DC ESS BUS, DC BUS 1 supplies CAPT (or F/O) loudspeaker when AUDIO SWITCHING selector is set to CAPT (or F/O) on 3.