

 AIRBUS TRAINING A320 SIMULATOR FLIGHT CREW OPERATING MANUAL	ELECTRICAL	1.24.00	P 1
	CONTENTS	SEQ 001	REV 23

24.00 CONTENTS

24.10 DESCRIPTION

– GENERAL	1
– GENERATION OF ELECTRICAL POWER	3
– OPERATIONS	5

24.20 CONTROLS AND INDICATORS

– OVERHEAD PANEL	1
– EXTERNAL POWER PANEL	7
– FORWARD CABIN	8
– ECAM ELECTRIC PAGE	9
– WARNINGS AND CAUTIONS	17
– MEMO DISPLAY	18

 AIRBUS TRAINING A320 SIMULATOR FLIGHT CREW OPERATING MANUAL	ELECTRICAL	1.24.10	P 1
	DESCRIPTION	SEQ 001	REV 23

GENERAL

The electrical power system consists of a three-phase 115/200-volt 400-hertz constant-frequency AC system and a 28-volt DC system.
 Electrical transients are acceptable for equipment.
 Commercial supply has secondary priority.
 Normally, the system produces alternating current, some of which it then transforms into direct current for certain applications.
 Each of the aircraft's three generators can supply the whole network.
 If all normal AC generation is lost, an emergency generator can supply AC power.
 If all AC generation is lost, the system can transform DC power from the batteries into AC power.



FOR INFO

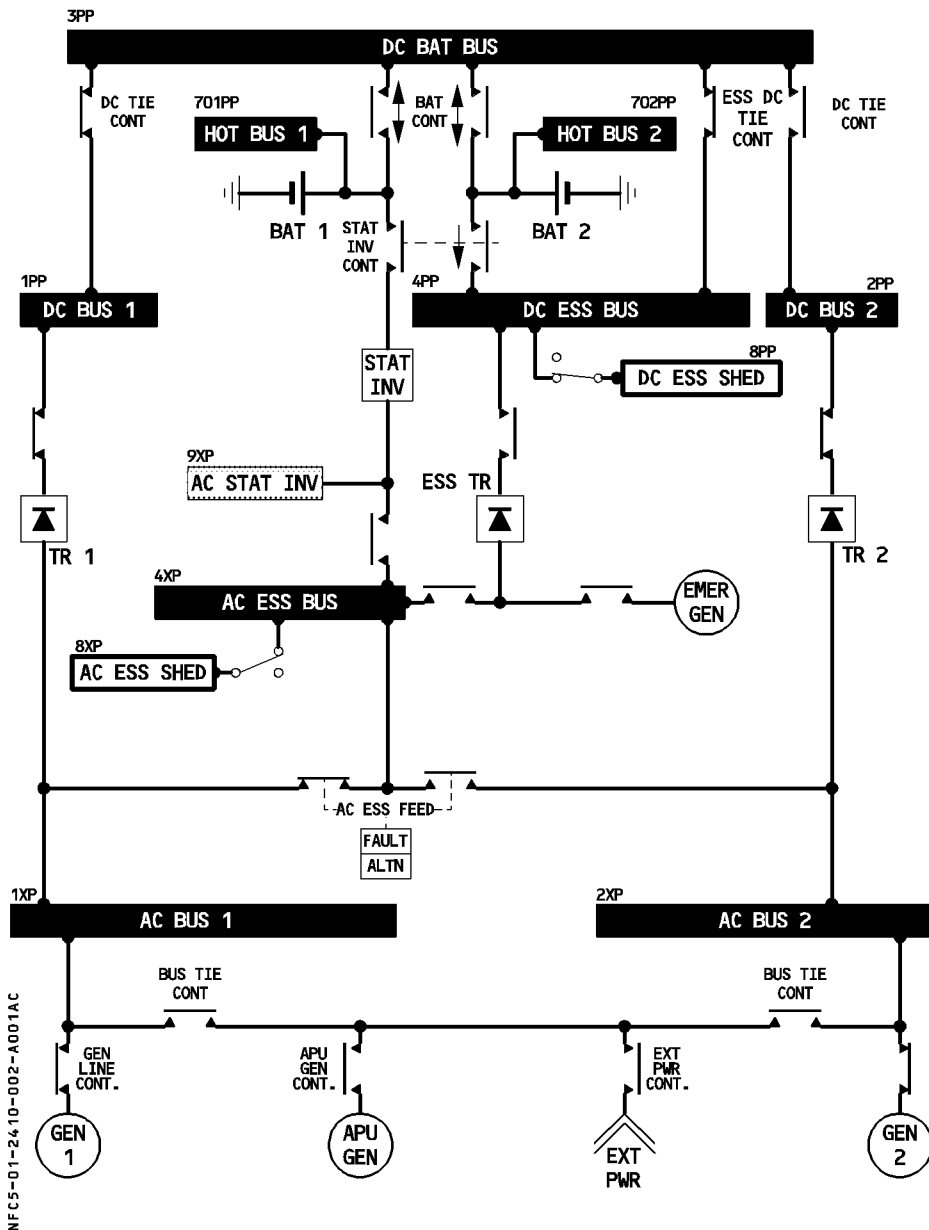

 AIRBUS TRAINING A320 SIMULATOR FLIGHT CREW OPERATING MANUAL	ELECTRICAL	1.24.10	P 3
	DESCRIPTION	SEQ 001	REV 23

GENERATION OF ELECTRICAL POWER

AC GENERATORS

MAIN GENERATORS

Two three-phase AC generators (GEN 1, GEN 2), one driven by each main engine through an integrated drive, supply aircraft electrical power. Each generator can supply up to 90 KVA of power at 115 and 200 volts and 400 hertz.

A third generator (APU GEN), driven directly by the APU and producing the same output as each main engine generator, can replace either or both main engine generators at any time.

A Generator Control Unit (GCU) controls the output of each generator. The main functions of each GCU are :

- Control the frequency and voltage of the generator output.
- Protect the network by controlling the associated Generator Line Contactor (GLC).

EXTERNAL POWER

A ground power connector near the nose wheel allows ground power to be supplied to all bus bars.

A Ground Power Control unit (GPCU) protects the network by controlling the external power contactor.

EMERGENCY GENERATOR

The blue hydraulic circuit drives an emergency generator that automatically supplies emergency AC power to the aircraft electrical system if all three main generators fail. This generator supplies 5 KVA of three-phase 115/200-volt 400-hertz power.

A Generator Control Unit (GCU) :

- keeps the emergency generator at a constant speed
- controls the generator's output voltage
- protects the network by controlling the emergency generator line contactor
- controls the emergency generator start-up

 AIRBUS TRAINING A320 SIMULATOR FLIGHT CREW OPERATING MANUAL	ELECTRICAL	1.24.10	P 4
	DESCRIPTION	SEQ 100	REV 36

STATIC INVERTER

A static inverter transforms DC power from Battery 1 into one KVA of single-phase 115-volt 400-hertz AC power, which is then supplied to part of the AC essential bus. When the aircraft speed is above 50 knots, the inverter is automatically activated, if nothing but the batteries are supplying electrical power to the aircraft, regardless of the BAT 1 and BAT 2 pushbutton positions.

When the aircraft speed is below 50 knots, the inverter is activated, if nothing but the batteries are supplying electrical power to the aircraft, and the BAT 1 and BAT 2 pushbuttons are both on at auto.

DC GENERATION

TRANSFORMER RECTIFIERS (TRs)

Two main transformer rectifiers, TR 1 and TR 2, supply the aircraft's electrical system, with up to 200 amperes of DC current.

A third (identical) transformer rectifier, the ESS TR, can power the essential DC circuit from the emergency generator, if the engine and APU generators all fail, or if TR 1 or TR 2 fails. Each TR controls its contactor by internal logic.

BATTERIES

Two main batteries, each with a normal capacity of 23 ampere-hours, are permanently connected to the two hot buses.

Each battery has an associated Battery Charge Limiter (BCL).

The BCL monitors battery charging and controls its battery contactor.

CIRCUIT BREAKERS (C/Bs)

The aircraft has two types of C/Bs :

- Monitored (green) : When out for more than one minute, the C/B TRIPPED warning is triggered on the ECAM.
- Non-monitored (black).

The Wing Tip Brakes (WTB) C/Bs have red caps on them to prevent them from being reset. The C/B TRIPPED warning on the ECAM indicates the location of the affected C/B. The following panels are monitored : OVHD PNL, L(R) ELEC BAY, REAR PNL J-M or N-R or S-V or W-Z.

R Note : The C/B TRIPPED, caution may be cleared from the ECAM by pressing the CLR or
 R the EMER CANCEL pushbutton. If the EMER CANCEL is used, and if a second C/B
 R is tripped on the same panel, the corresponding C/B TRIPPED caution will not be triggered.

	ELECTRICAL	1.24.10	P 5
	DESCRIPTION	SEQ 001	REV 23

OPERATIONS

GENERAL

GEN 1 and 2 when operating have priority over the APU generator and over external power. External power has priority over the APU generator when the EXT PWR pushbutton switch is ON.

The APU generator or external power can supply the entire network.

One engine generator can supply the entire network.

The generators cannot be connected in parallel.



NORMAL CONFIGURATION

IN FLIGHT

Each engine-driven generator supplies its associated AC BUS (1 and 2) via its generator line contactor (GLC 1 and GLC 2).

AC BUS 1 normally supplies DC ESS BUS via a contactor.

TR 1 normally supplies DC BUS 1, DC BAT BUS, and DC ESS BUS.

TR 2 normally supplies DC BUS 2.

The two batteries are connected to the DC BAT BUS if they need charging. When they are fully charged the battery charge limiter disconnects them.

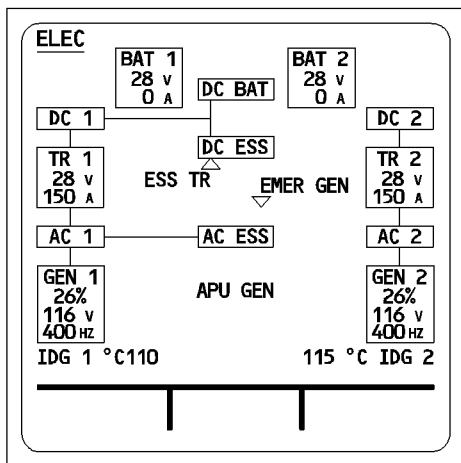

NFCS-01-2410-006-A001AA



ON GROUND

Either the APU generator or external power may supply the complete system.

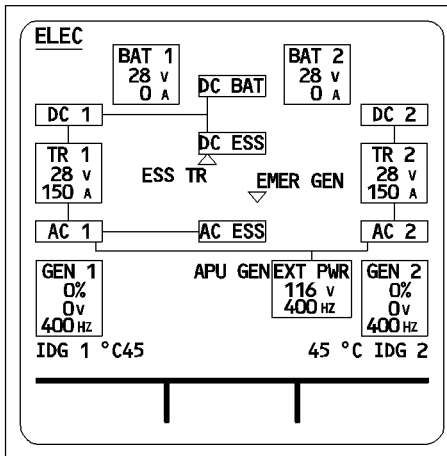

EXTERNAL POWER ONLY

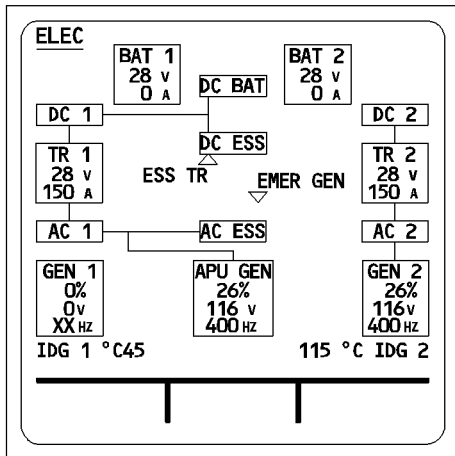

APU GEN + GEN 2

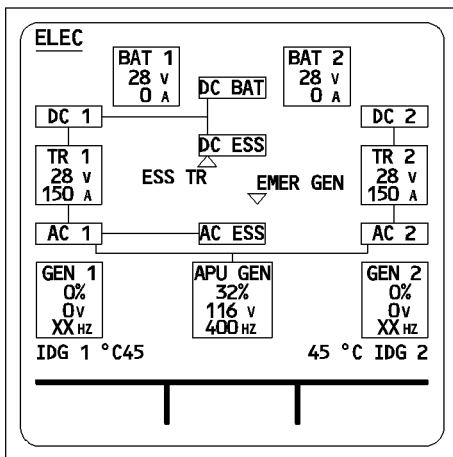

APU GEN ONLY

NFC5-01-24.10-007-A001AA



On ground, when only ground services are required, external power can supply the AC and DC GND/FLT BUSES directly without supplying the entire aircraft network. Personnel select this configuration with the MAINT BUS switch in the forward entrance area.

FOR INFO

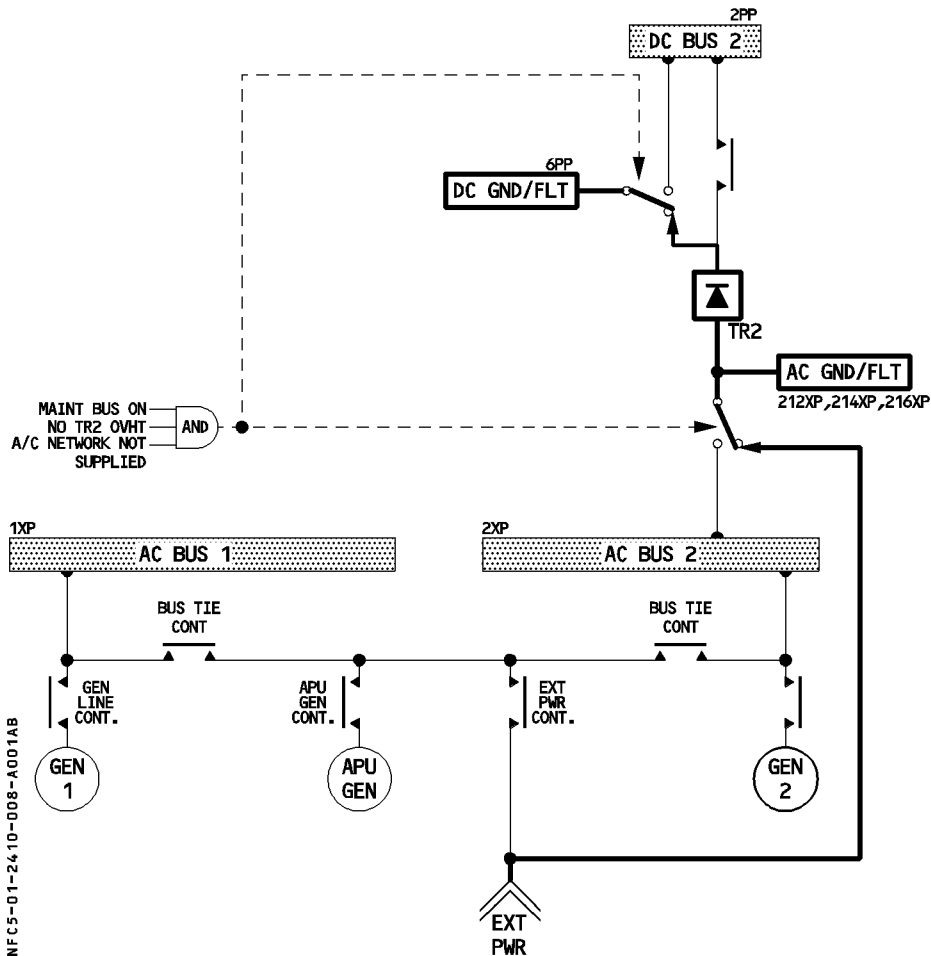



ABNORMAL CONFIGURATIONS

FAILURE OF ONE ENGINE GENERATOR

The system automatically replaces the failed generator with

- the APU GEN if available, or
- the other engine generator (automatically shedding part of the galley load).

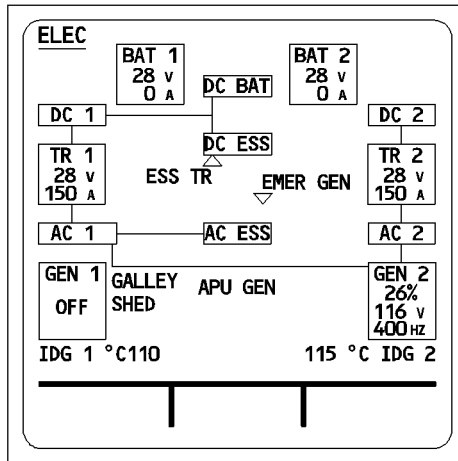

NFC5-01-2410-009-A001AA



FAILURE OF AC BUS 1

- The AC BUS 2 can supply the AC ESS BUS and the ESS TR can supply the DC ESS BUS, both through the AC ESS FEED pushbutton switch.
- The DC BUS 2 supplies the DC BUS 1 and DC BAT BUS automatically after 5 seconds.

NFC5-01-2410-010-A001AA

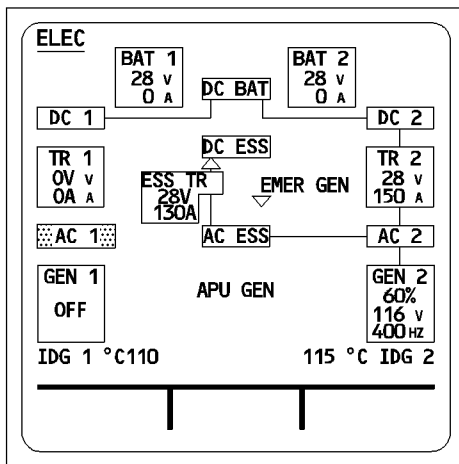



FAILURE OF ONE TR

The contactor of each TR opens automatically in case of :

- overheat
- minimum current

The other TR automatically replaces the faulty one.

The ESS TR supplies the DC ESS BUS.

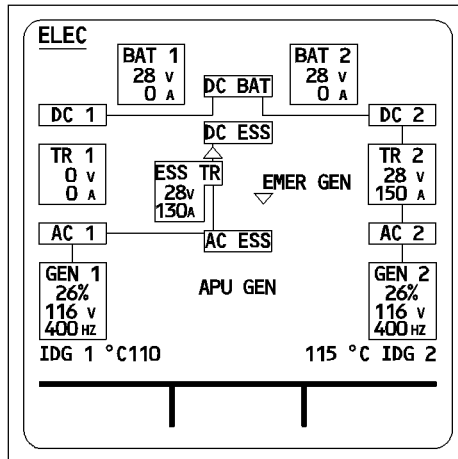

NFCS-01-2410-011-A001AA



FAILURE OF TR 1 AND TR 2

If TR 1 and TR 2 are lost, DC BUS 1, DC BUS 2, and DC BAT BUS are lost. The DC ESS BUS is supplied by the ESS TR.

NFC5-01-2410-012-A001AA

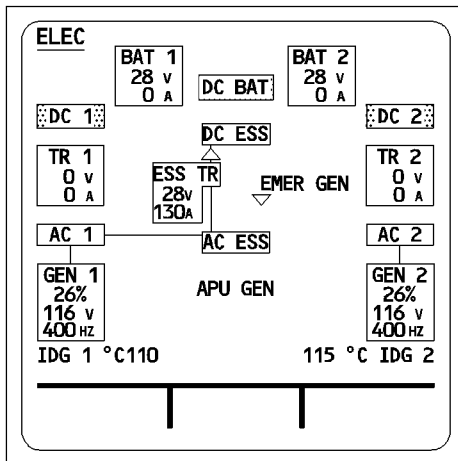

EMERGENCY GENERATION AFTER LOSS OF ALL MAIN GENERATORS

If both the AC BUS 1 and AC BUS 2 buses are lost and the aircraft speed is above 100 knots, the Ram-Air Turbine (RAT) extends automatically. This powers the blue hydraulic system, which drives the emergency generator by means of a hydraulic motor. This generator supplies the AC ESS BUS, and the DC ESS BUS via the ESS TR.

If the RAT stalls or if the aircraft is on the ground with speed below 100 knots, the emergency generator has nothing to drive it. The emergency generation network transfers automatically to the batteries and static inverter, and the system automatically sheds the AC SHED ESS and DC SHED ESS buses.

When the aircraft is on the ground :

- Below 100 knots the DC BAT BUS is automatically connected to the batteries.
- Below 50 knots the AC ESS BUS is automatically shed, leading to the loss of all CRTs.

R Note : During RAT extension and emergency generator coupling (about 8 seconds), the batteries power the emergency generation network.

EMER GEN RUNNING

NFC5-01-2410-013-A100AA

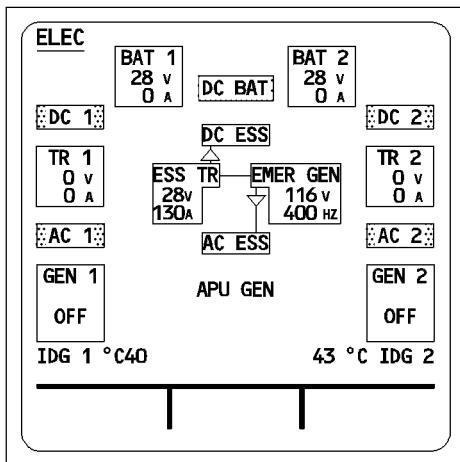

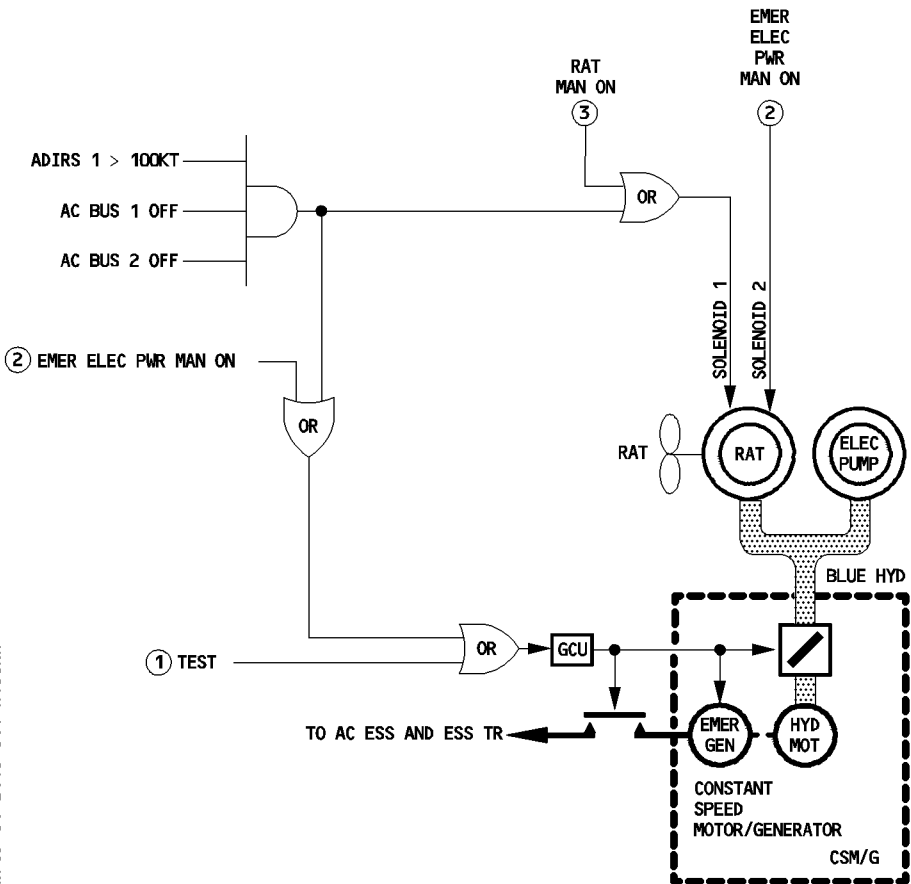
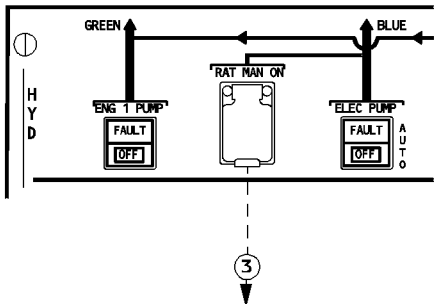
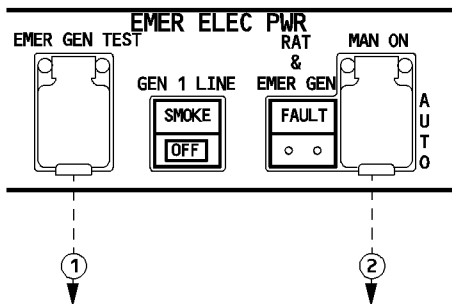

NFC5-01-24-10-014-A100AA



ON GROUND, BATTERIES ONLY (speed < 50 kt)

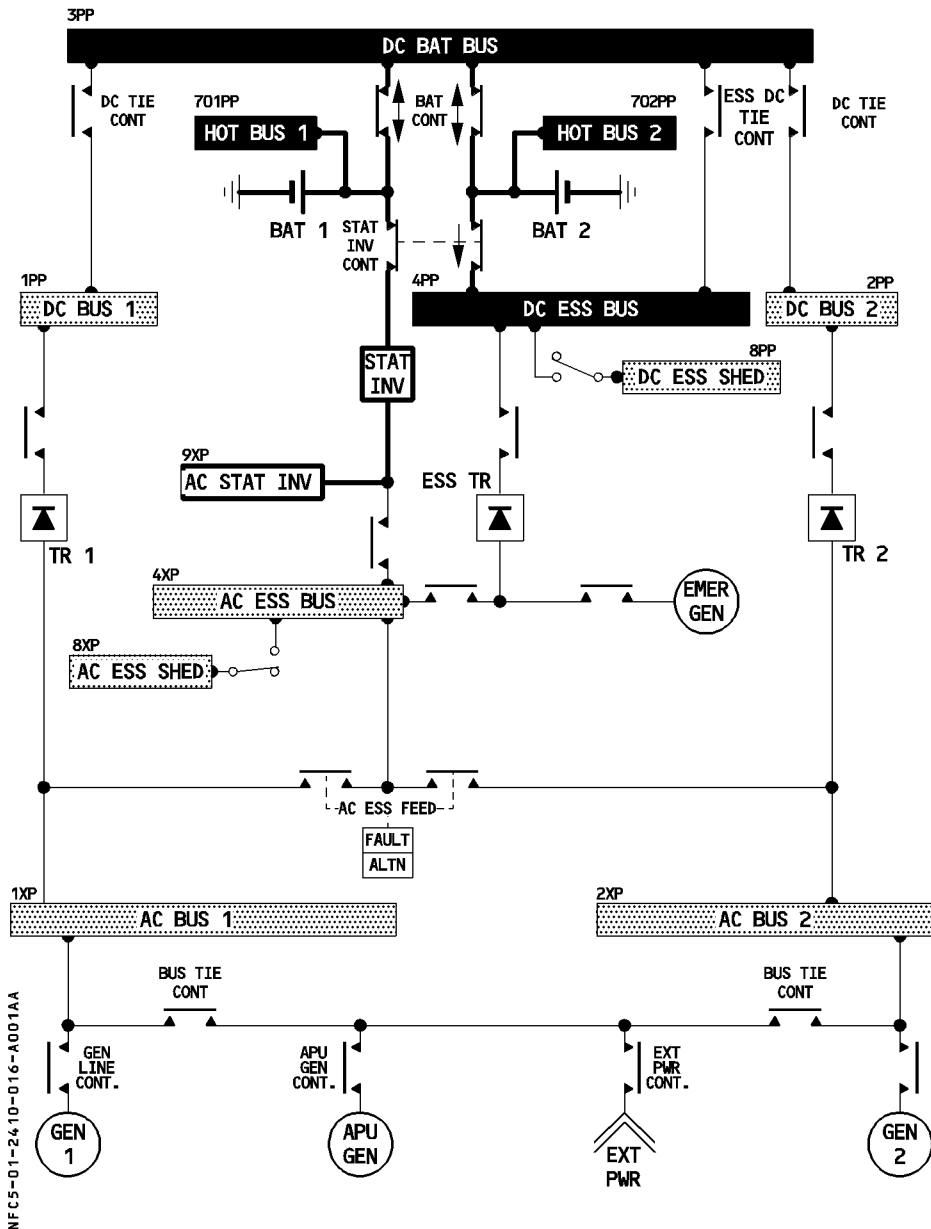

NFCS-01-24.10-016-A001AA



SMOKE CONFIGURATION

- R In this configuration the main bus bars are shedded. The electrical distribution is the same as it is in the emergency configuration (loss of main generators), except that the fuel pumps are connected upstream of the GEN 1 line connector. The procedure sheds about 75 % of electrical equipment. All equipment that remains powered is supplied through C/Bs on the overhead panel (except for that which is supplied by hot buses).

R

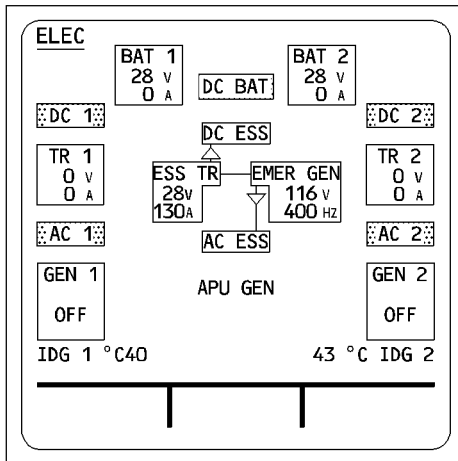

NFC5-01-24.10-017-4.001AB



SMOKE configuration

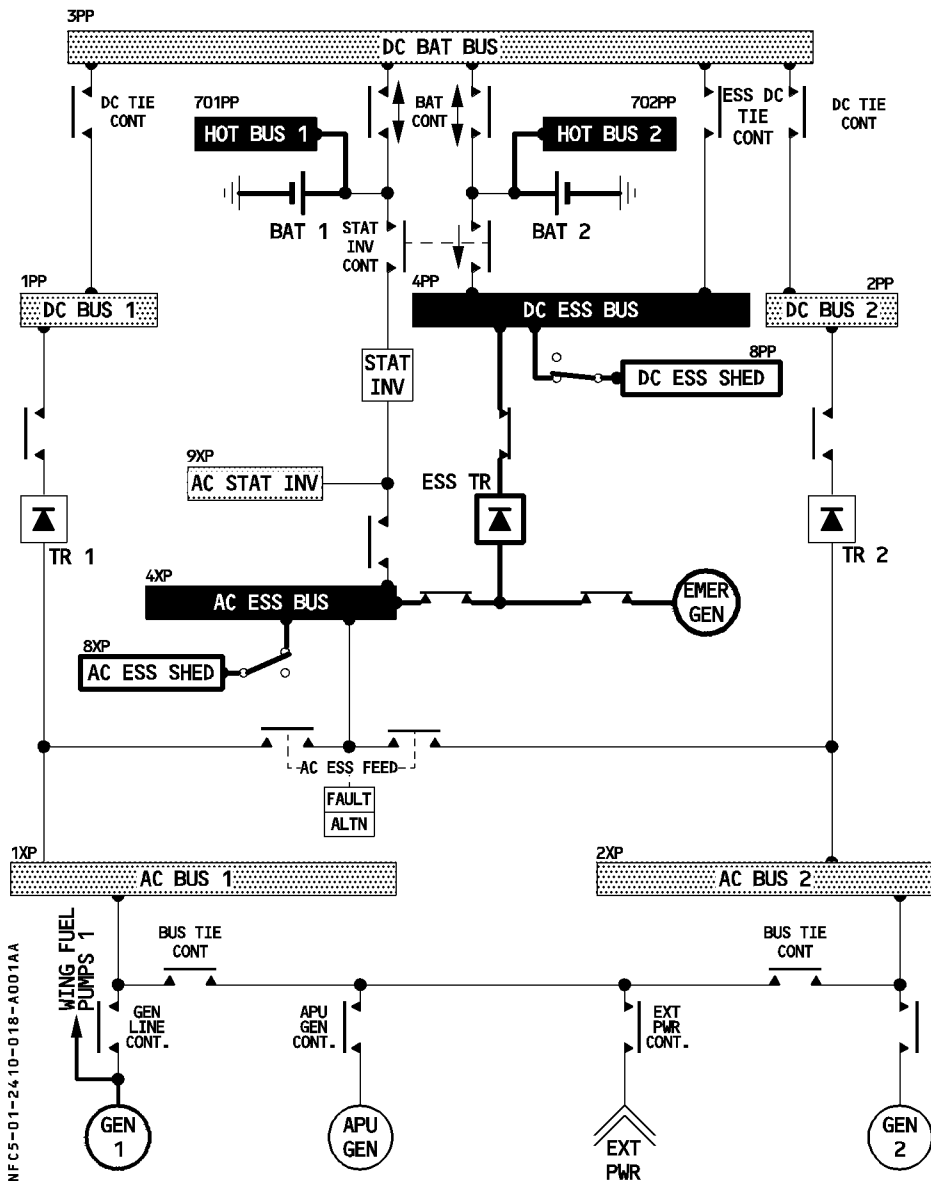

Note : ECAM ELEC page is identical to that for emergency generator running.

DISTRIBUTION TABLE

R

	AC BUS 1	AC BUS 2	AC ESS BUS	AC SHED ESS	AC STAT INV	TR1	TR2	ESS TR	DC BUS 1	DC BUS 2	DC BAT BUS	DC ESS BUS	DC SHED ESS	HOT BUS 1	HOT BUS 2
NORM CONF	GEN1	GEN2	GEN1	GEN1	-	GEN1	GEN2	-	TR1 GEN1	TR2 GEN2	TR1 GEN1	TR1 GEN1	TR1 GEN1	BAT1	BAT2
ONE GEN INOP AVAIL-X- (1,2 or APU)	GENX	GENX	GENX	GENX	-	GENX	GENX	-	TR1 GENX	TR2 GENX	TR1 GENX	TR1 GENX	TR1 GENX	BAT1	BAT2
EMER CONF BEFORE EMER GEN AVAILABILITY (about 8 sec)	-	-	ST INV BAT1	-	ST INV BAT1	-	-	-	-	-	-	BAT2	-	BAT1	BAT2
EMER GEN RUNNING	-	-	EMER GEN	EMER GEN	-	-	-	EMER GEN	-	-	-	ESS TR EMER GEN	ESS TR EMER GEN	BAT1	BAT2
TR1 FAULT	GEN1	GEN2	GEN1	GEN1	-	-	GEN2	GEN1	TR2 GEN2	TR2 GEN2	TR2 GEN2	ESS TR GEN1	ESS TR GEN1	BAT1	BAT2
TR2 FAULT	GEN1	GEN2	GEN1	GEN1	-	GEN1	-	GEN1	TR1 GEN1	TR1 GEN1	TR1 GEN1	ESS TR GEN1	ESS TR GEN1	BAT1	BAT2
TR1 + 2 FAULT	GEN1	GEN2	GEN1	GEN1	-	-	-	GEN1	-	-	-	ESS TR GEN1	ESS TR GEN1	BAT1	BAT2

ON GROUND BAT. ONLY	AC BUS 1	AC BUS 2	AC ESS BUS	AC SHED ESS	AC STAT INV	TR1	TR2	ESS TR	DC BUS 1	DC BUS 2	DC BAT BUS	DC ESS BUS	DC SHED ESS	HOT BUS 1	HOT BUS 2
Speed > 100kt	-	-	EMER GEN	EMER GEN	-	-	-	EMER GEN	-	-	-	ESS TR EMER GEN	ESS TR EMER GEN	BAT1	BAT2
rat stall or 50 kt ≤ speed ≤ 100 kt	-	-	ST INV BAT1	-	ST INV BAT1	-	-	-	-	-	BAT 1-2	BAT2	-	BAT1	BAT2
speed < 50 kt	-	-	-	-	ST INV BAT1	-	-	-	-	-	BAT 1-2	BAT2	-	BAT1	BAT2



OVERHEAD PANEL

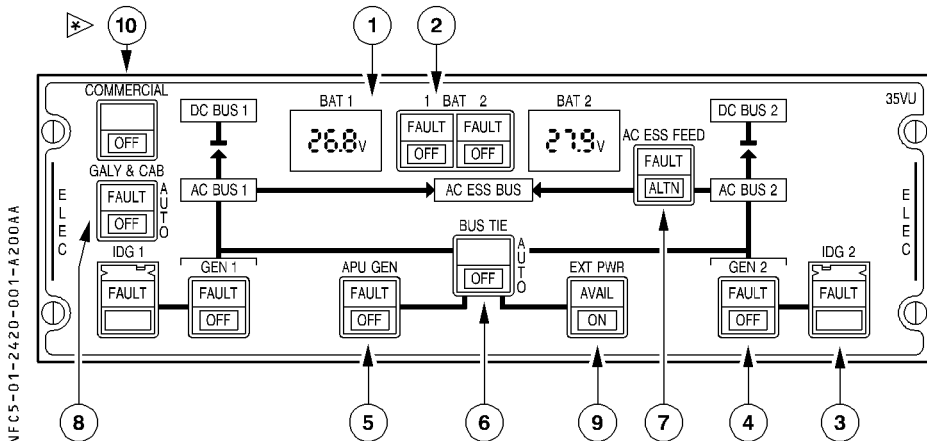

① BAT 1(2) ind.

Shows battery voltage in white.

	ELECTRICAL	1.24.20	P 2
	CONTROLS AND INDICATORS	SEQ 200	REV 23

② BAT 1 (2) pb sw

Controls the operation of the corresponding battery charge limiter.

Auto : The battery charge limiter controls automatically the connection and the disconnection of the corresponding battery to the DC BAT BUS (3 PP) by closing and opening of the battery line contactor.

- The batteries are connected to the DC BAT BUS in the following cases :
 - APU starting (MASTER SW at ON and N < 95%).

Note : *The connection is limited to 3 minutes when the emergency generator is running.*

- Battery voltage below 26.5 V (battery charge). The charging cycle ends when battery charge current goes below 4 amperes.
 - on ground, immediately
 - in flight, after a time delay of 30 minutes.
- Loss of AC BUS 1 and 2 when below 100 knots (EMER GEN not supplying).
- If AC BUS 1 and 2 are not energized and emergency generator is not supplying :
 - battery 1 supplies the AC STAT INV BUS, and, if speed is greater than 50 kt, the AC ESS BUS.
 - battery 2 supplies the DC ESS BUS.

Note : *In normal configuration the batteries are disconnected most of the time.*

Note : *A battery automatic cut-off logic prevents the batteries from discharging completely when the aircraft is on the ground (parking).*

Automatic battery contactors open when :

- *The aircraft is on the ground.*
- *The BAT pushbutton switches are at AUTO.*
- *The main power supply (EXT PWR + GEN) is cut off.*
- *Battery voltage is low.*

The flight crew can reset the contactors by switching the BAT pushbutton switch to OFF then to AUTO.

OFF : The battery charge limiter is not operating : the battery line contactor is open.

OFF comes on white if the DC BAT BUS is supplied. Hot buses remain supplied.

FAULT It : Comes on amber, accompanied by an ECAM caution, when the charging current for the corresponding battery is outside limits.

In this case the battery contactor opens.

 A320 <small>SIMULATOR</small> FLIGHT CREW OPERATING MANUAL	ELECTRICAL	1.24.20	P 3
	CONTROLS AND INDICATORS	SEQ 001	REV 23

③ IDG 1 (2) (Integrated Drive Generator) pb sw (guarded)

CAUTION

1. Holding this pushbutton switch in for more than about 3 seconds may damage the disconnection mechanism.
2. Do not disconnect the IDG when the engine is not running (or not windmilling), because starting the engine after having done so will damage the IDG.

The IDG switches are normally springloaded out.

Pressing this switch disconnects the IDG from its driveshaft : only maintenance personnel can reconnect it.

FAULT It : Lights up amber, and ECAM caution comes on, if :

- IDG oil outlet overheats (above 185°C), or
 - IDG oil pressure is low (inhibited at low engine speed : N2 below 14 %)
- It extinguishes when the IDG is disconnected.

④ GEN 1 (2) pb sw

ON : The generator field is energized and the line contactor closes if electrical parameters are normal.

OFF : The generator field is de-energized and the line contactors opens. The fault circuit is reset.

FAULT It : Lights up amber, and an ECAM caution comes on, if :

- The associated generator control unit (GCU) trips it.

Note : If a differential fault trips the protection, reset action has no effect after two attempts.

- Opening of the line contactor (except if the GEN pushbutton switch is selected OFF)

⑤ APU GEN pb sw

ON : The APU generator field is energized and the line contactor closes if parameters are normal and the EXT PWR line contactor is open. The bus tie contactor 1 (2) closes automatically if GEN 1 (2) is not operating.

OFF : The generator field is de-energized and the line contactor opens. The fault circuit is reset.

FAULT It : Same as GEN 1 or 2 **FAULT**

The APU GEN **FAULT** light is inhibited when APU speed is too low or if the APU GEN line contactor opens after EXT PWR or ENG GEN takes over.

 A320 SIMULATOR FLIGHT CREW OPERATING MANUAL	ELECTRICAL	1.24.20	P 4
	CONTROLS AND INDICATORS	SEQ 100	REV 28

⑥ BUS TIE pb sw

- AUTO** : The bus tie contactors (BTCs) open or close automatically in order to maintain power supply to both AC BUS 1 and AC BUS 2.
- One contactor is closed when :
 - One engine generator supplies the associated AC BUS, and
 - The APU generator or external power supplies the other side.
 - Both contactors are closed during single-engine operation, or operation on the APU generator or external power supply.
- OFF** : Both bus tie contactors open.

⑦ AC ESS FEED pb sw

- The AC ESS BUS is normally supplied from AC BUS 1.
 It may be supplied by AC BUS 2 through the AC ESS FEED pushbutton switch.
- NORMAL** : The AC ESS BUS is supplied from AC BUS 1.
- ALTN** : The AC ESS BUS is supplied from AC BUS 2.
- FAULT It** : Comes on amber, and ECAM caution comes on, when the AC ESS BUS is not electrically supplied.

Note : In case of total loss of main generators, the AC ESS BUS is automatically supplied by the emergency generator, or by the static inverter if the emergency generator is not available.

⑧ GALY & CAB pb sw

- AUTO** : Main galley, secondary galley and in-seat power supply ◁ are supplied.
 The main galley and in-seat power supply ◁ are shed automatically when :
- In flight : only one generator is operating.
 - On the ground : only one engine generator is operating. (All galleys are available when the APU GEN or EXT PWR is supplying power.)
- OFF** : The main galley, secondary galley and in-seat power supply ◁ are not supplied.
- FAULT It** : Comes on amber, and ECAM caution comes on, when the load on any generator is more than 100 % of rated output.

 AIRBUS TRAINING A320 SIMULATOR FLIGHT CREW OPERATING MANUAL	ELECTRICAL	1.24.20	P 5
	CONTROLS AND INDICATORS	SEQ 001	REV 23

⑨ EXT PWR pb (momentary action)

AVAIL light comes on green if :

- external power is plugged in, and
- external power parameters are normal.

Pressed momentarily :

- If the AVAIL light was on :
 - The external power line contactor closes.
 - The AVAIL light goes off.
 - The ON light comes on blue.
- If the ON light was on :
 - The external power line contactor opens.
 - The ON light goes off.
 - The AVAIL light comes on.

*Note : 1. External power has priority over the APU generator. The engine generators have priority over external power.
 2. The ON light stays on even when the engine generators supply the aircraft.*

⑩ COMMERCIAL pb sw ◀

- ON** : All aircraft commercial electrical loads are supplied :
- cabin and cargo lights
 - water and toilet system
 - drain mast ice protection
 - galley
 - passengers' entertainment
 - semi-automatic cargo loading (if installed)
- OFF** : Switches off all aircraft commercial electrical loads.

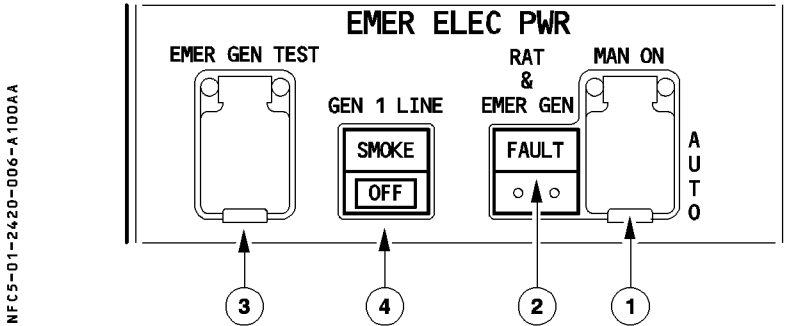

① MAN ON pb (guarded)

AUTO : When the following conditions are met :

- AC BUS 1 is not electrically supplied.
- AC BUS 2 is not electrically supplied.
- Aircraft speed is greater than 100 knots.
 - The RAT extends.
 - The blue hydraulic system drives the emergency generator.
 - As soon as the emergency generator electrical parameters are within tolerance the emergency generator is connected to the aircraft network.

Pressed : This selects manual RAT extension.

R
R Emergency generator coupling occurs 3 seconds after the RAT is supplying the emergency generator.

② FAULT It

This light comes on red if the emergency generator is not supplying power when AC BUS 1 and AC BUS 2 are not powered.

③ EMER GEN TEST pb (guarded)

Pressed and held :

- If AC NORMAL BUSES are supplied :
 - The EMER GEN is driven hydraulically if the blue electric pump is running. The AC ESS BUS and the DC ESS BUS are connected to the emergency generator. (The DC ESS SHED and AC ESS SHED buses are not powered.)
 - ECAM displays the ELEC page automatically (only on the ground).
- If only the batteries supply the aircraft :
 - The static inverter powers the AC ESS BUS.



④ GEN 1 LINE pb sw

- OFF** : GEN 1 line contactor opens.
The AC BUS 1 channel is supplied from GEN 2 through bus tie contactors. This is used for smoked drill.
- SMOKE It** : (Refer to 1.26)

EXTERNAL POWER PANEL

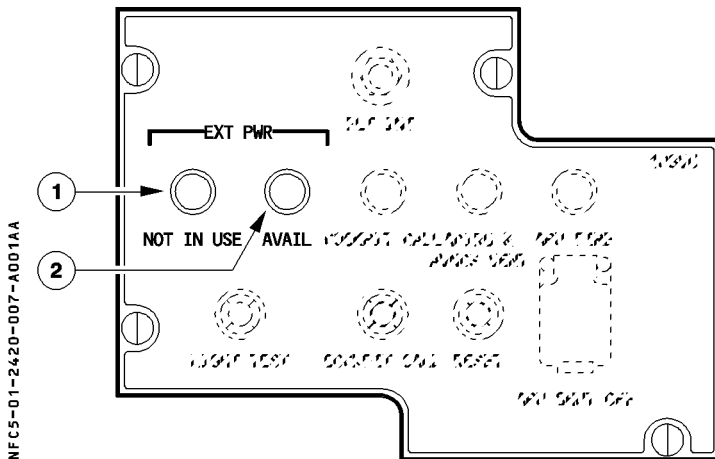

① EXT PWR NOT IN USE

This white light comes on to inform ground personnel that the ground power unit is not supplying the aircraft network and can be removed.

② EXT PWR AVAIL

This amber light comes on to indicate that external power is available and the voltage is correct.



FORWARD CABIN

MAINT BUS sw :

NFC5-01-2420-008-A001AA

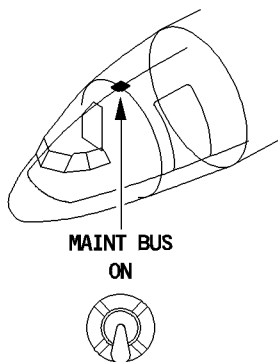

This switch allows personnel to energize electrical circuits for ground servicing without energizing the entire aircraft electrical system.

ON : The switch latches magnetically if external power is connected and normal (AVAIL light on).

The AC and DC GND/FLT buses have power and the following loads can be energized :

- passenger compartment lighting
- galley lighting
- entrance area lights
- lavatory lighting and service
- vacuum cleaner sockets
- flight compartment service outlets
- hydraulic pump (yellow system)
- flight compartment flood lighting
- fuel quantity indications
- refueling
- cargo hold lighting
- main and nose landing gear compartment lighting
- belly fairing panel service outlets
- ground call
- equipment compartment lights and service outlets
- navigation lights.

The switch trips when the external source is removed.

OFF : The AC and DC GND/FLT buses are connected to AC BUS 2 and DC BUS 2.



ECAM ELEC PAGE

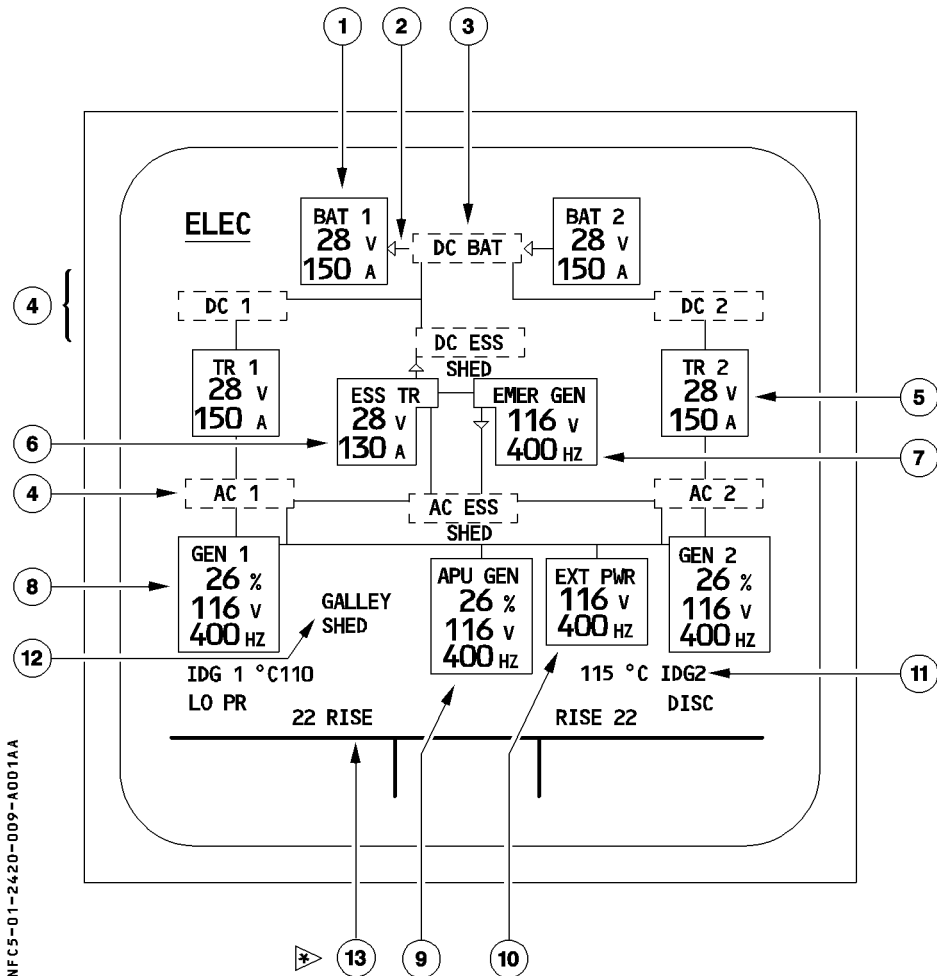

MFC5-01-2420-009-A001AA



① Battery indications

- BAT pushbutton switch at OFF :
Legend is in white.

NFC5-01-2420-010-A001AA

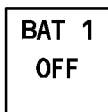

- BAT pushbutton switch at Auto :

NFC5-01-2420-010-B001AA

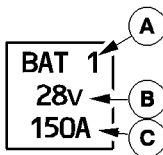

- Ⓐ Legend is normally white, but becomes amber
 - when voltage and current indications change to amber, or
 - in case of a BAT FAULT warning.
- Ⓑ Battery voltage is normally green, but becomes amber if $V > 31\text{ V}$ or $V < 25\text{ V}$.
- Ⓒ Battery current is normally green, but becomes amber if discharge current $> 5\text{ A}$.

② Battery charge/discharge indication

NFC5-01-2420-010-C001AA

- ⊖ BATTERY CONTACTOR CLOSED. BATTERY CHARGING CURRENT $> 1\text{ A}$ (GREEN)
- ⊕ BATTERY CONTACTOR CLOSED. BATTERY DISCHARGE CURRENT $> 1\text{ A}$ (AMBER)
- ⊖ BATTERY CONTACTOR CLOSED. CURRENT $< 1\text{ A}$ (GREEN)
- | BATTERY CONTACTOR OPEN.

③ DC BAT indication

This legend normally green, becomes amber if DC BAT voltage ≤ 25 V.

④ Bus indication

This label, normally green, becomes amber when the corresponding bus is off. SHED appears in amber when AC or DC SHED ESS BUS is off.

⑤ TR 1 (2) indication

NFCS-01-2420-011-AB01AA

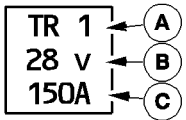

- Ⓐ Normally white, this legend becomes amber when legends B and C do.
- Ⓑ The TR voltage, normally green, becomes amber if $V > 31$ V or $V < 25$ V.
- Ⓒ The TR current, normally green, becomes amber when the TR current ≤ 5 A.

⑥ ESS TR indication

NFCS-01-2420-011-B001AA

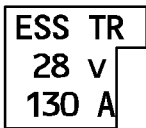

This legend follows the logic described above for the TR 1 (2) legend. The voltage and current are not displayed when the essential TR contactor is open.



⑦ EMER GEN indication

NFCS-01-2420-012-4001AA

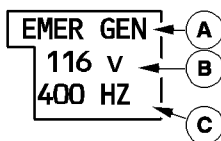

- Ⓐ This legend, normally white, becomes amber when either the voltage or frequency legend becomes amber.
- Ⓑ This legend, normally green, becomes amber if $V > 120 \text{ V}$ or if $V < 110 \text{ V}$.
- Ⓒ This legend, normally green, becomes amber if $F > 410 \text{ Hz}$ or if $F < 390 \text{ Hz}$.
Voltage and frequency indications are not displayed when the EMER GEN line contactor is open.

⑧ GEN 1/2 indications

- GEN pushbutton switch is OFF :
 GEN is amber.
 OFF indication is white
 1 or 2 indication is white if the associated engine is running, amber if it is not.

NFC5-01-2420-013-A001AA

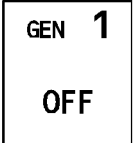

- GEN pushbutton switch is ON.

NFC5-01-2420-013-B001AA

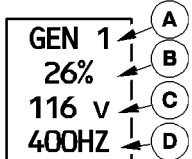

- Ⓐ GEN1 or GEN2, normally white, becomes amber if any of the following legends become amber.
- Ⓑ The load legend, normally green, becomes amber if load > 100 %.
- Ⓒ The voltage legend, normally green, becomes amber if V > 120 V or V < 110 V.
- Ⓓ The frequency legend, normally green, becomes amber if F > 410 Hz or F < 390 Hz.



9 APU GEN indications

- When the APU MASTER switch is OFF this legend is white regardless of the position of the APU GEN pushbutton switch.

NFC5-01-2420-014-A001AA

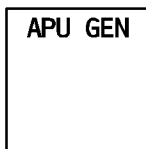

- When the APU MASTER switch is ON, and the APU GEN pushbutton switch is OFF:
The APU GEN legend is amber.
The OFF legend is white.

NFC5-01-2420-014-B001AA

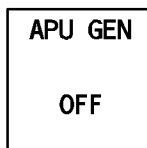

- When the APU MASTER switch is ON and the APU GEN pushbutton switch is ON :
The indications are the same as for GEN 1 (2).

NFC5-01-2420-014-C001AA

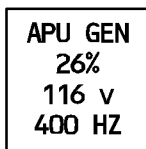

⑩ EXT PWR indications

– External power is not available.

NFCS-01-2420-015-1001AA



– When external power is available :

NFCS-01-2420-015-8001AA

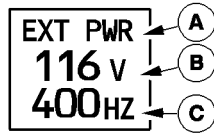

- Ⓐ This legend is normally white, but becomes amber, if either of the following legends turns amber.
- Ⓑ This legend is normally green, but becomes amber, if $V > 120 V$ or if $V < 110 V$.
- Ⓒ This legend is normally green, but becomes amber, if $F > 410 Hz$ or if $F < 390 Hz$.

NFCS-01-2420-015-C001AA

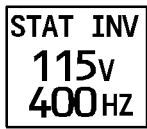

- R – This legend appears during the static inverter test, and when pressing the ELEC pushbutton on the ECAM control panel while ESS BUSES are supplied by the batteries. It is normally green, but becomes amber, if :
 $V < 110 V$ or $V > 120V$.
 $F < 390 Hz$ or $F > 410 hz$.



11 IDG indications

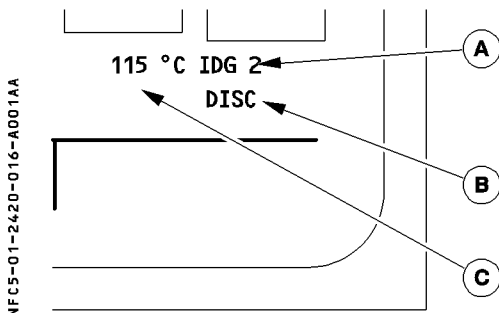

(A) IDG1 (2) legend

The IDG legend, normally white, becomes amber if

- Oil outlet temperature > 185° C.
- Oil pressure gets too low.
- IDG becomes disconnected.

The 1 or 2 is white if the corresponding engine is running, amber if it is not and the FADEC is powered.

(B) DISC/LO PR indication

The DISC legend appears in amber when the IDG is disconnected.

LO PR appears in amber when IDG low pressure is detected and the associated engine is running.

(C) Oil outlet temperature

This legend, normally green, appears amber if $T > 185^{\circ}\text{C}$. It flashes if $147^{\circ}\text{C} < T < 185^{\circ}\text{C}$ (advisory).

12 GALLEY SHED indication

This legend appears in white when :

- GALLEY pushbutton switch is OFF, or
- the main galleys are shed, meaning :
 - In flight, only one generator is operating.
 - On the ground, the aircraft is being supplied by one engine generator only.

The legend is not displayed when the aircraft is in its normal configuration.

13 RISE indication ◀

This number, displayed in green, is the difference between the temperature at the IDG inlet and that at the IDG outlet.

WARNINGS AND CAUTIONS

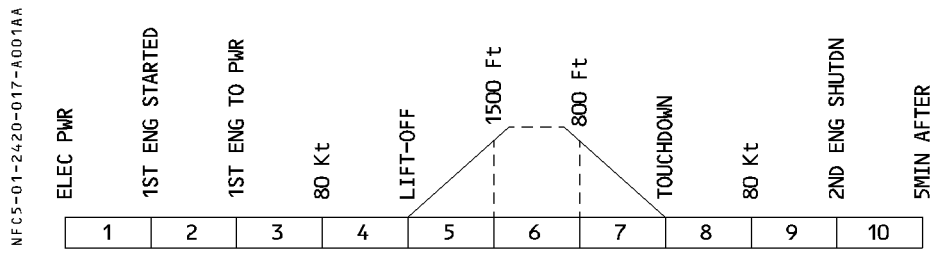

R

E / WD : FAILURE TITLE conditions	AURAL WARNING	MASTER LIGHT	SD PAGE CALLED	LOCAL WARNINGS	FLT PHASE INHIB
EMER CONFIG Loss of main generators.	CRC	MASTER WARN	NIL *	RAT and EMER GEN FAULT It	4, 8
ESS BUSES ON BAT DC and AC ESS BUSES are supplied by batteries			ELEC		1, 2, 3, 4, 8, 9, 10
AC BUS 1 FAULT AC BUS 2 FAULT AC ESS BUS SHED DC BUS 1 FAULT DC BUS 2 FAULT DC BUS 1 + 2 FAULT DC ESS BUS FAULT DC ESS BUS SHED Bus(es) is (are) no longer supplied.	SINGLE CHIME	MASTER CAUTION	ELEC	NIL	4, 8
AC ESS BUS FAULT Bus is no longer supplied.				AC ESS FEED FAULT It	
DC BAT BUS FAULT Bus is no longer supplied.				NIL	4, 5, 7, 8
DC EMER CONFIG DC BUS 1 and 2 and DC ESS BUS are not supplied.				NIL	4, 8
GEN 1(2) FAULT · Protection trip initiated by associated GCU, or · Opening of line contactor with GEN pb ON.				GEN 1(2) FAULT	1, 4, 5, 7, 8, 10
GEN 1(2) OFF. GEN 1(2) pb OFF with no FAULT.				NIL	1, 3, 4, 5, 7, 8, 10

* The flight crew must call up the ELEC page on the upper ECAM by pressing and holding the ELEC pushbutton on the ECAM control panel.



E / WD : FAILURE TITLE conditions	AURAL WARNING	MASTER LIGHT	SD PAGE CALLED	LOCAL WARNINGS	FLT PHASE INHIB	
APU GEN FAULT · Protection trip initiated by associated GCU, or · Opening of line contactor with APU GEN pb ON.	SINGLE CHIME	MASTER CAUTION	ELEC	APU GEN FAULT It	4, 5, 7, 8	
GEN 1(2) or APU GEN OVERLOAD Load of one generator is above 100 % of rated output				GALLEY FAULT It	3, 4, 5, 7, 8	
IDG 1(2) OIL LO PR IDG oil pressure low				IDG 1(2) FAULT It	1, 4, 5 7, 8, 10	
IDG 1(2) OIL OVHT IDG outlet oil temp above 185°C				BAT 1(2) FAULT It	3, 4, 5 7, 8	
BAT 1(2) FAULT Charging current increases at an abnormal rate			NIL	ELEC	NIL	1, 3, 4, 5 7, 8, 9, 10
ESS TR FAULT						
C/B TRIPPED ON OVHD PNL C/B TRIPPED ON L (R) ELEC BAY C/B TRIPPED REAR PNL J-M or N-R or S-V or W-Z One C/B tripped in the designated zone.						
BAT 1(2) OFF BAT pb OFF without fault.	NIL	NIL	ELEC	3, 4, 5 7, 8		
TRI 1(2) FAULT						
BCL 1(2) FAULT						
STATIC INV FAULT			NIL	NIL	1, 3, 4, 5 7, 8, 9, 10	
EMER GEN 1 LINE OFF GEN 1 LINE pb in OFF position.						

MEMO DISPLAY

EMER GEN is displayed in green, when the emergency generator is running.