



# HYDRAULIC SYSTEM

1.12.00

PAGE 1/2

## CONTENTS

REV 14

SEQ 001

### 12.10 HYDRAULIC SYSTEM

### R 12.20 MAINTENANCE PANEL

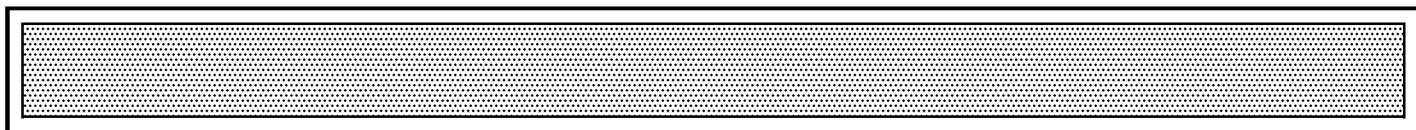

**GENERAL**

The aircraft has three completely independent hydraulic systems, which operate simultaneously. They are designated BLUE, GREEN, YELLOW.

Each system is supplied from its own hydraulic reservoir. There are no provisions for routing of hydraulic fluid from one system to the other.

Four identical, engine driven hydraulic pumps, 2 on each engine, pressurize the systems with a delivery pressure of 3,000 PSI :

- GREEN 2 pumps, one on each engine,
- BLUE 1 pump on engine 1,
- YELLOW 1 pump on engine 2.

Two non-reversible power transfer units are installed to provide for power transfer without fluid exchange, from the GREEN system to the BLUE or to the YELLOW system. They are required in case of power generation failure (e.g. in case of engine failure or engine pump failure) and also for ground testing.

If the engine driven pumps are not available, hydraulic power may also be generated by :

- Two electric pumps in the GREEN system (primarily intended for ground testing).
- One electric pump in the YELLOW system to pressurize the brake accumulators (Parking/ALTN-OFF brakes) if required, or to operate the main cargo compartment doors.
- A ram air turbine (RAT) driven pump in the YELLOW system to supply emergency hydraulic power.
- A hand pump in the YELLOW system to operate the main cargo compartment doors when the YELLOW electric pump is not available.

Hydraulic power is fed directly to the servo controls manifolds and then to the high pressure manifolds, which are permanently linked. The servo control manifolds supply the primary flight controls, spoilers and wing tip brakes through a servo controls selector valve.

R The high pressure manifolds are equipped with a priority valve which isolates slat, flap, gear, krueger and nose gear steering operating systems, when the pressure has dropped below 1,885 PSI which gives priority to Flight Controls.  
 (See chapter FLIGHT CONTROLS for detailed information).

In the event of engine fire the engine driven pumps are isolated from their hydraulic reservoirs by the FIRE VALVES. When an ENG FIRE handle is pulled, the respective valves close. In the yellow system, the FIRE valve closes also in case of LO LVL.  
 The position of the FIRE VALVES is indicated on the lateral panel.

**RESERVOIRS**

The hydraulic fluid reservoirs, are of different capacities for each individual system. The low level for each is 5 ltr (1,3 US gal).

- GREEN On the rear wall of the main gear and hydraulics bay, normal filling level 17 ltr (4,5 US gal)

- BLUE Inside the LH wing root, normal filling level 12 ltr (3,2 US gal)

- YELLOW Inside the RH wing root, normal filling level 18.5 ltr (4,9 US gal)

The YELLOW reservoir will retain a fluid reserve of 3 ltr (0,8 US gal), which is strictly for RAT operation.

To avoid pump cavitation, all reservoirs are automatically pressurized to 50 PSI by engine bleed air, APU bleed air or by a ground air supply.  
 Individual replenishing is possible from the GREEN system ground service panel.

Each reservoir is provided with :

- an electrical, float type quantity transmitter,
- a pneumatic pressure switch for low air pressure warning,
- a temperature switch in the return line for high temperature warning,
- a compartment feature ensures positive fluid supply to the pumps during negative « g » conditions of up to 20 seconds.
- a direct reading level indicator.

**ENGINE DRIVEN PUMPS**

Two variable displacement pumps are installed on the accessory gearbox of each engine :

- Engine 1 : one green and one blue system pump.
- Engine 2 : one green and one yellow system pump.

They are identical and of the self-regulating multipiston type. The nominal output flow of 136 ltr/min (35,9 USgal/min) is delivered at a pressure of 3000 PSI.

A solenoid operated dump valve in each pump allows depressurization of the pump in case of pump or related system failure. Each valve is controlled by the corresponding PUMPS pushbutton switch on the HYD PWR section of the overhead panel.

FIRE VALVES, which are shutoff valves on the suction side of each pump, isolate the hydraulic fluid supply to the pump, when the respective ENG FIRE handle is pulled.

**ELECTRIC PUMPS**

The GREEN system is provided with two identical soft-compensated and self-regulating hydraulic pumps, driven by AC motors.

The nominal output flow is as follows :

- 0 ltr/min : 3,000 PSI
- 23 ltr/min (6 US gal/min) : 2,830 PSI
- 36 ltr/min (9,5 US gal/min) : 1,670 PSI

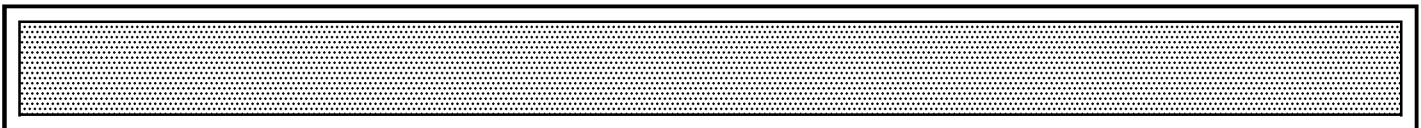

Both pumps are controlled simultaneously by a pushbutton switch on the HYD PWR section of the overhead panel. When operated, the complete GREEN system is pressurized. Electrical power supply for the AC motors is from AC BUS 1 and AC BUS 2 respectively.

The YELLOW system is provided with a self-regulating hydraulic pump, which is driven by an AC motor. The nominal output flow of 6 ltr/min (1,6 US gal/min) is delivered at 2 850 PSI. The pump is controlled by the PARKING BRAKE ACCU PRESS pushbutton on the center pedestal, near the PARKING BRAKE control handle, and by the OPEN/CLOSE selectors located adjacent to the main cargo compartment doors.

Pressurization of the complete YELLOW system by the electric pump is prevented by manifold check valves. When the PARKING BRAKE ACCU PRESS pushbutton is operated or when an OPEN/CLOSE cargo door selection is made, the parking ALTN-OFF brakes accumulators, and the main cargo compartment door operation circuit only are pressurized.

### **RAM AIR TURBINE (RAT)**

The RAT consists of a self-regulating hydraulic pump driven by a constant speed propeller. It is connected to the YELLOW system and will pressurize it when extended into the airstream.

The nominal output flow is 45 ltr/min (11,9 US gal/min) delivered at a pressure of 2,800 PSI, provided the airspeed is **140 Kts** or more.

The RAT unit is fixed to an extendable leg. Stowed in a compartment in the lower right wing root adjacent to the RH main gear and hydraulics compartment. Two RAT handles are installed, one on each side console.

Operation of either handle mechanically unlocks the RAT. It extends by springforce, simultaneously opening the compartment doors. In the down position it is mechanically locked and cannot be retracted. It can only be restowed on the ground.

The RAT is used to supply emergency hydraulic power for aircraft control, if two or all hydraulic systems have failed, or in case of dual engine flame out.

The RAT may be deployed throughout the whole flight envelope, the response time (time between release and the appearance of nominal pressure) is less than 6.5 seconds.

### **POWER TRANSFER UNITS (PTU)**

Two identical PTU are provided, one between the GREEN and BLUE systems, the other between the GREEN and YELLOW systems.

Each PTU consists of an hydraulic motor driven by GREEN hydraulic pressure, and an hydraulic pump in the receiving system. Motor and pump are connected by a drive shaft.

Each motor has an electrovalve which controls pressurized GREEN hydraulic supply to the motor, the GREEN pressure being generated by the engine pump or the green electric pumps.

The nominal output of the pump in the BLUE or in the YELLOW system is 90 ltr/min (23,8 US gal/min) at a pressure of 2,500 PSI ; with no flow demand the pressure is 3,000 PSI. Each motor in the GREEN system requires 111 ltr/min (29,3 US gal/min) at 3000 PSI to produce the nominal pump output. Only one PTU may be operated at a time.

Each PTU is controlled by a pushbutton switch on the HYD PWR section of the overhead panel, which operates the motor electrovalve. A PTU may be used in flight in case of hydraulic power generation failure in the BLUE or the YELLOW system. On ground, with the GREEN system pressurized by both electric pumps, they are used to pressurize the BLUE or the YELLOW system for maintenance purpose.

Electrical power for both PTU solenoid valves is from the 28 DC normal bus.

### **HAND PUMP**

A hand pump is installed on the aft wall of the RH main gear and hydraulics compartment. It is not accessible in flight. During ground operation it may be used to operate the main cargo compartment doors, if the YELLOW electric pump is not available. Only the cargo compartment door section of the YELLOW system is pressurized by the hand pump.

The hand pump lever is stowed on the aft wall close to the pump.

### **GROUND SERVICE PANELS**

For each system a ground service panel is provided with delivery, suction and reservoir depressurization connectors.

For reservoir pressurization a common air pressure connector is fitted on the blue system service panel.

For reservoir replenishing a common connector, reservoir selector and reservoirs hydraulic quantity repeated indicator is situated on the green service panel.

### **HIGH PRESSURE MANIFOLD EQUIPMENT**

Each high pressure manifold is equipped with :

- one pressure switch
- two pressure transmitters,
- an overpressure relief/manual relief valve (manual relief on ground only).
- a priority valve.

R

The YELLOW system manifold is also fitted with two Parking/ALTN-OFF braking accumulators and is therefore additionally equipped with :

- an overpressure relief valve (for the brake accumulator system)
- one common pressure transmitter for both brake accumulators

The pressure switches signal low pressure, at the HP manifold to the ECAM system (SYS LO PR warning). The pressure transmitters signal the manifold pressure to the ECAM system. Braking accumulator pressure is indicated separately by the ACCU PRESS indicator on the center instrument panel.

The overpressure relief valves open to the return lines, if system pressure exceeds 3,440 PSI. On ground they can be opened manually by pressing a pushbutton on the valve, if system depressurization is required.

The priority valve is used to cut off hydraulic power to heavy load users in the event of low hydraulic pressure thus ensuring, priority to the servo controls. They close when the downstream pressure drops to 1 885 PSI.

### **SERVO CONTROL MANIFOLD EQUIPMENT**

Each servo control manifold is equipped with :

- one pressure switch
- R - one servo control selector valve

The pressure switches signal low pressure downstream of the servo manifold to the ECAM system (SERVO LO PR warning).

The servo control selector valve is used to isolate the respective hydraulic system in the event of a control surface servo jam or fluid loss.

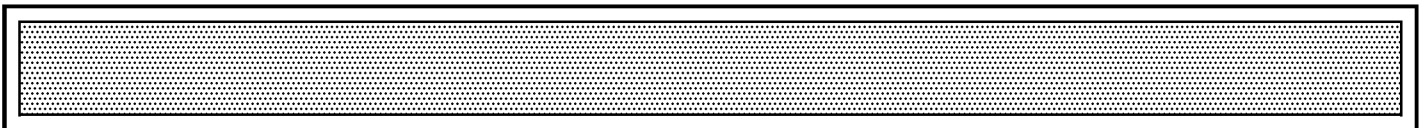

SYSTEMS ARRANGEMENT

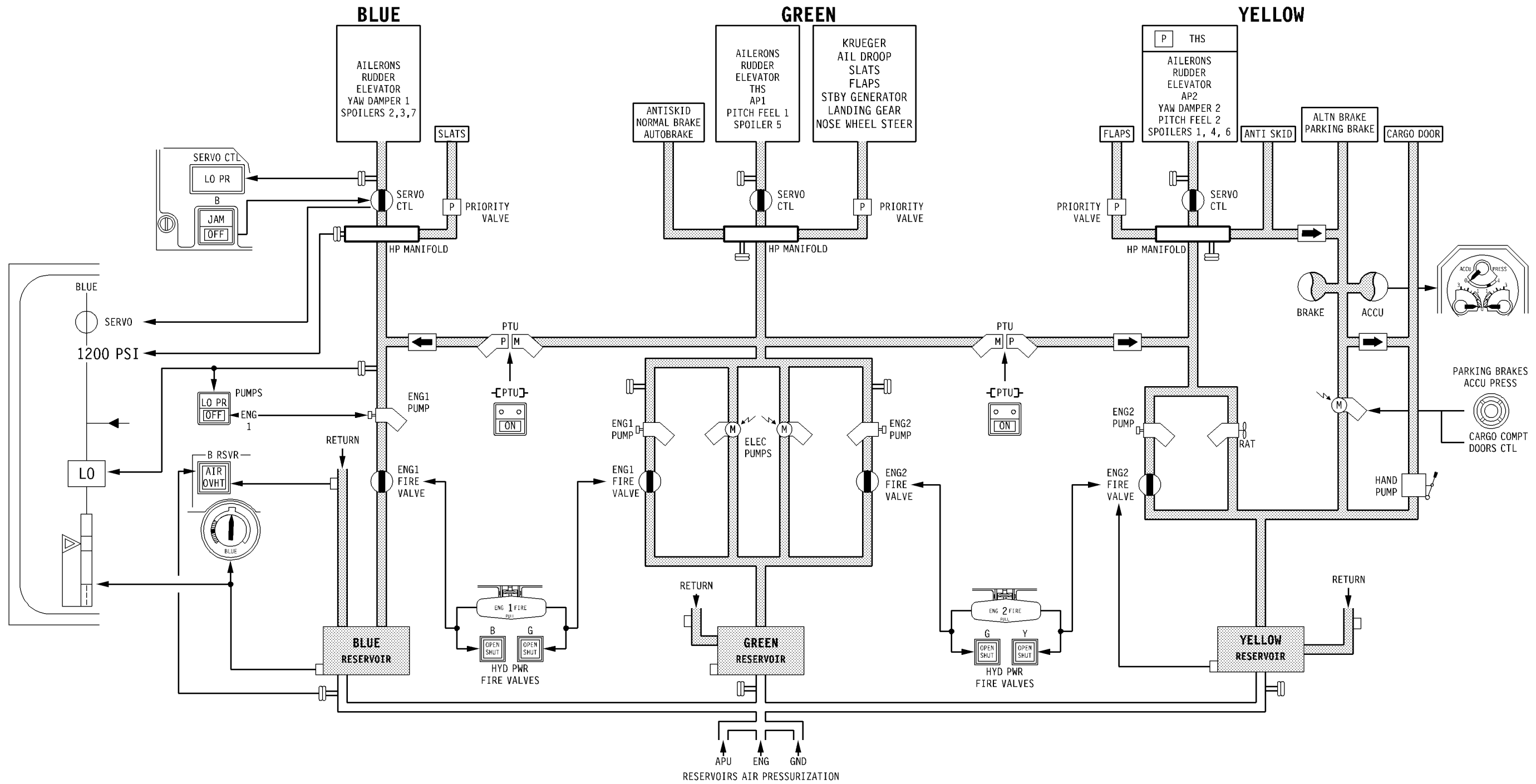

80FC-01-1210-001-A11048

Mod : 5911

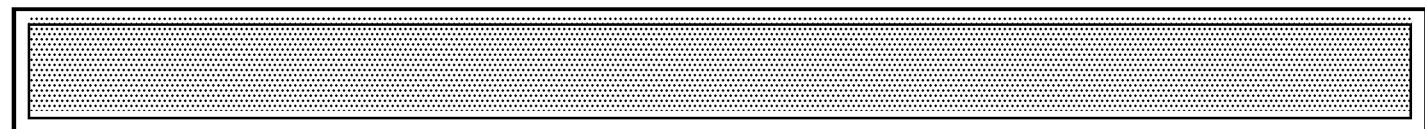

### RAM AIR TURBINE

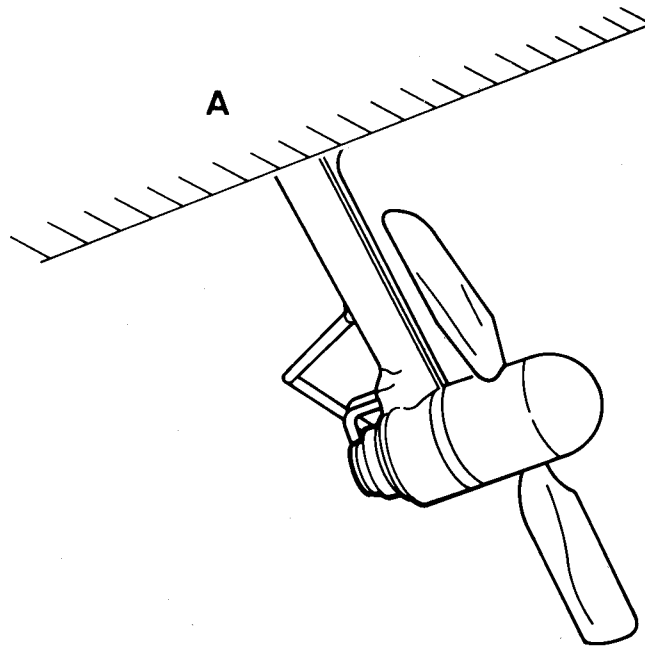
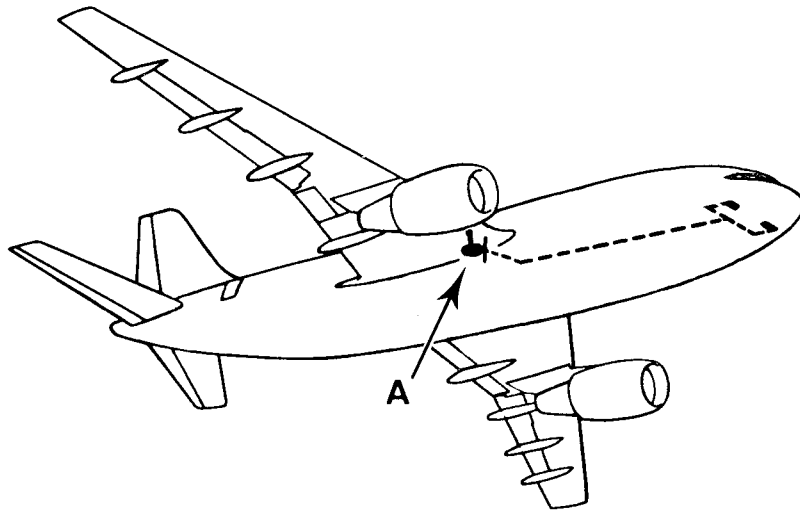

FB1.1210.005-AA.001

Vers. : All

Eng. : All

## LOCATION OF CONTROLS

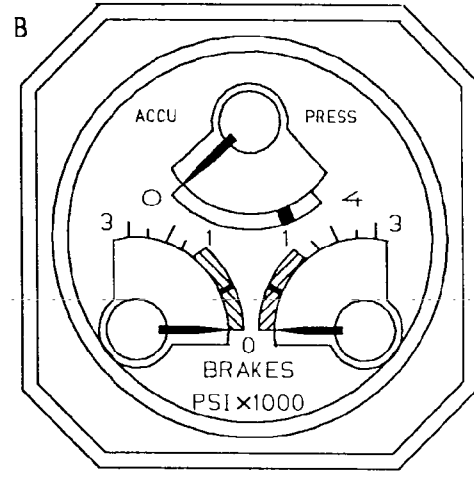
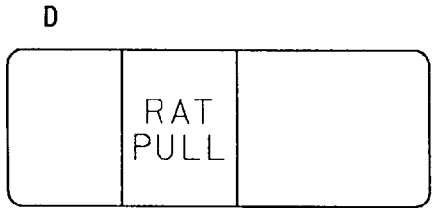
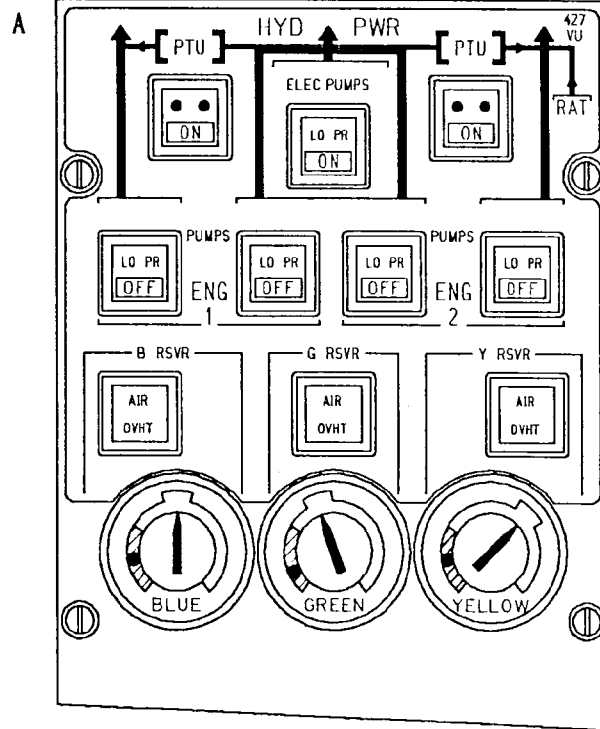
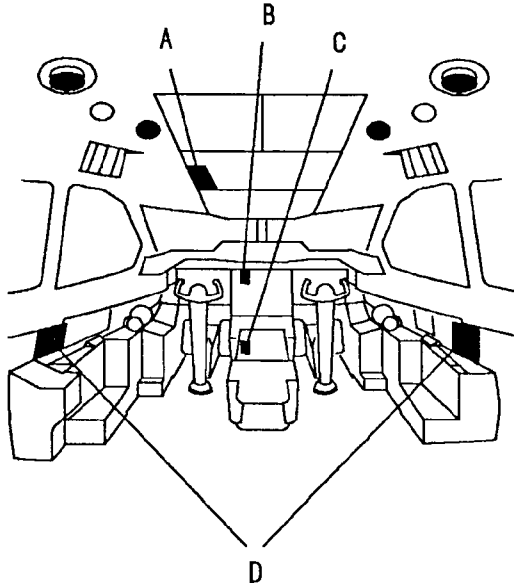

PARKING BRAKE  
 ACCU PRESS

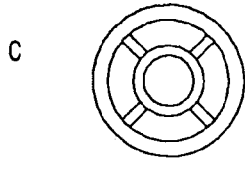

OPS.FCO.B1.1210.006-AC.050

Mod. : 4803

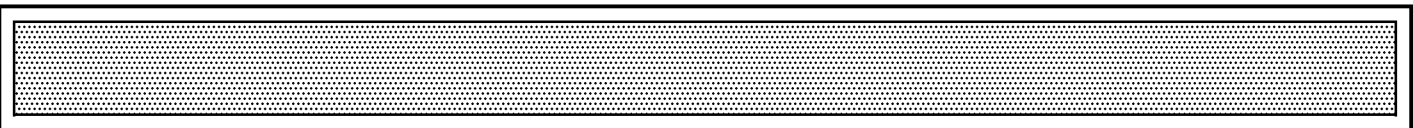

**A. HYD PWR PANEL**

**– Reservoirs and Fluid**

FB1.1210.007-AA.020

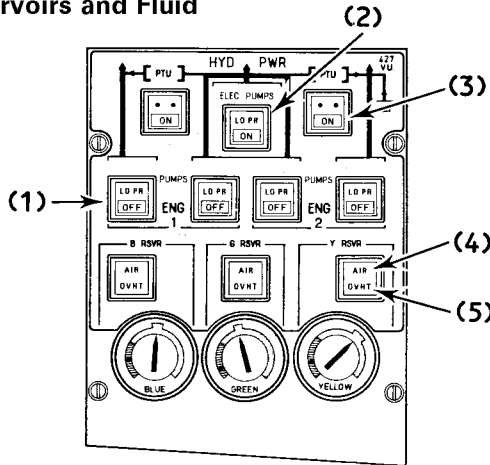

**(1) PUMPS ENG, 1, B and G/ENG 2, G and Y Pushbutton Switches**

Control activation and deactivation of engine pumps by operating the respective pump pressure dump valve.

- **On (PB-Switch pressed - in, magnetically latched)**  
Pump set for power generation
- **OFF (PB - Switch pressed - out)**  
OFF light comes on white.  
Power generation stops.  
Lubrication and cooling of pump continues. An OFF selection activates the ECAM system (LO PR light goes out, if OFF selected following LO PR warning).
- **LO PR**  
The light comes ON amber, if - with the respective PUMPS switch selected ON - pump delivery pressure decreases below 1,800 PSI.  
The light goes off, when the pressure increases above 2,200 PSI.  
Illumination of the LO PR light is accompanied by ECAM activation.

**R (2) ELEC PUMPS Pushbutton Switch**

Controls simultaneously the operation of both electric pumps in the GREEN system. A LO PR and an ON indication are integrated in the pushbutton switch.

- **ON (PB-Switch pressed - in)**  
ON light comes on WHITE. Electric pumps are activated. One pump operates immediately, the second starts with a 3 seconds delay.

- **Off (PB-Switch released - out)**  
ON light is off. Both pumps are deactivated.
- **LO PR**  
The light comes on amber if - with ELEC PUMPS switch selected ON - the total delivery pressure of both pumps is below 1740 PSI with an increasing pressure and below 1450 PSI with a decreasing pressure.  
Illumination of the LO PR light is accompanied by ECAM activation.

*Note : The switch trips out as soon as the DC NORM BUS is not supplied.*

**(3) PTU Pushbutton Switches**

Control the power transfer without fluid exchange from GREEN to BLUE and/or from GREEN to YELLOW systems respectively.

- **ON (PB-Switch pressed - in)**  
ON light comes on green, PTU operation is started, power transfer operates as long as GREEN system pressure is available.
- **Off (Switch released - out)**  
ON light is off. Supply for PTU motor is shut off. Power transfer stops.

**(4) AIR Lights**

Come on amber associated with ECAM if the respective reservoir air pressure drops below 22 PSI. The lights will go off when the pressure increases to 25 PSI or more.

*Note : Reservoirs should maintain air pressure approximately at normal level for 12 hours after shutdown of pressure supply source.*

AIR lights may come on under negative-g conditions.

**(5) OVHT Lights**

Come on amber, associated with ECAM if the return hydraulic fluid temperature at the entry of the respective reservoir is 95° C or more.  
GREEN and YELLOW OVHT lights are inhibited in case of THS control valve jamming detection.

Mod : 4691

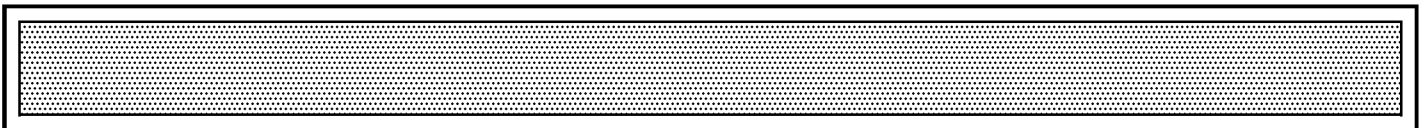



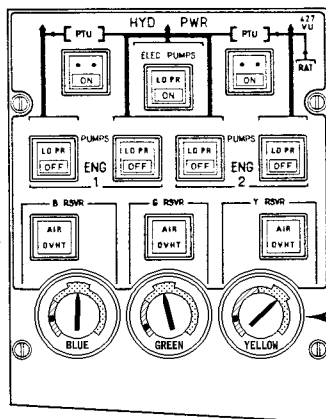

BOFC-01-1210-008-A200AA - R

**(6) Reservoir Quantity Indicators - BLUE, GREEN, YELLOW**

Indicate the fluid level in the respective hydraulic reservoir. If an indicator is not electrically supplied, the pointer may move to any position without warning.

*Note : Green reservoir level may fluctuate in flight due to thermal expansion, insufficient system bleeding or landing gear retraction.*

- **Green Arc**  
Normal usable range of hydraulic fluid.
- **Upper small green Arc**  
On ground, with reservoir pneumatically pressurized and hydraulic system depressurized.
  - . Pointer within upper small green arc indicates normal fluid level in reservoir.
  - . Pointer at max. limit of upper small green arc indicates max. normal fluid level in reservoir.
  - . Pointer at min. limit of upper small green arc indicates min. normal fluid level in reservoir.
- **Yellow Arc with Red Dot**
  - . Pointer within yellow arc indicates abnormal fluid level in reservoir. When pointer drops to, or below red dot, warning system is activated.

**B. ACCU PRESS CONTROLS**

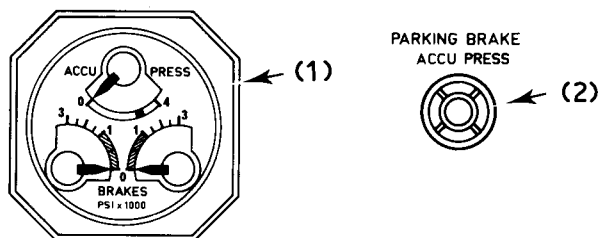

BOFC-01-1210-008-B200AA - R

Mod. : 4803 + 7378

**(1) ACCU PRESS Indicator**

Indicates accumulator pressure of the two brake accumulators in the YELLOW system, available for ALTN/OFF and for parking brakes. Pressure indication is in PSI X 1000. Sufficient pressure for PARKING BRAKE is maintained by the accumulator for approx. 12 hrs.

**(2) PARKING BRAKE ACCU PRESS Pushbutton**

Controls the electric pump in the YELLOW system, to operate it for recharging of brake accumulators to 3,000 PSI.

- **Pressed**  
Electric pump is activated. Pressure is self-regulated to 3,000 PSI.
- **Released**  
Electric pump is deactivated.

*Note : The yellow system hand pump cannot be used for recharging the brake accumulators.*

**C. HYD RAM AIR TURBINE HANDLES**

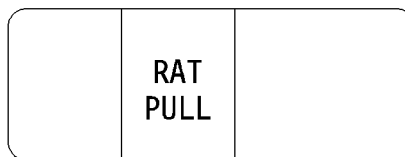

BOFC-01-1210-008-C200AA

The ram air turbine can only be extended by operation of either handle, located on LH and RH side console.

For extension put fingers into the groove and pull. R

*Note : The ram air turbine can be retracted and restowed on the ground only.* R

**SYSTEM DISPLAY**

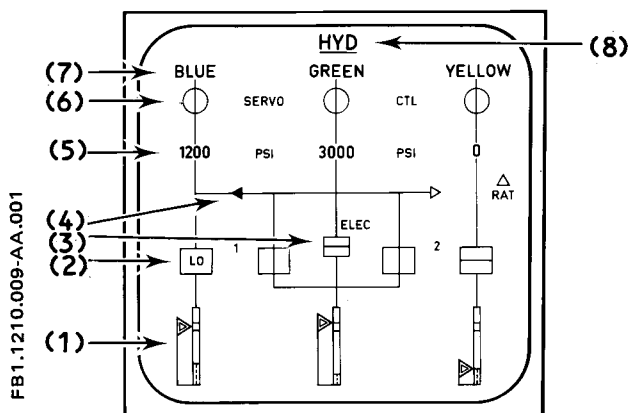

**(1) Reservoir level Indication :**

	BLUE	GREEN	YELLOW
Normal Filing	12 ltr 3,2 usgal	17 ltr 4,5 usgal	18.5 ltr 4,9 us gal
LOLEVELWarning	5 ltr 1,3 usgal	5 ltr 1,3 usgal	5 ltr 1,3 us gal

The lower part of the reservoir level indication and the triangle become amber when the fluid level is lower or equal to 5 ltr (1,3 US gal).

**(2) Engine Driven Pump Control and Low Pressure Indication :**

	Green	The pump is selected on and : – the fluid pressure > 2 200 PSI (if the pressure is increasing) – or the fluid pressure > 1 800 PSI (if the pressure is decreasing)
	Amber	The pump is selected on and : – the fluid pressure < 2 200 PSI (if the pressure is increasing) – or the fluid pressure < 1 800 PSI (if the pressure is decreasing)
	Amber	The pump is selected OFF

**(3) Electric Pumps Control and Low Pressure Indications**

	Green	The pumps are selected ON and : – the fluid pressure > 1 740 PSI (if the pressure is increasing) – or the fluid pressure > 1 450 PSI (if the pressure is decreasing)
	Amber	The pumps are selected ON and : – the fluid pressure < 1 740 PSI (if the pressure is increasing) – or the fluid pressure < 1 450 PSI (if the pressure is decreasing)
	Green	The pumps are selected OFF

**(4) Power Transfer Units Control :**

On the figure :  
the GREEN/BLUE PTU is selected ON  
the GREEN/YELLOW PTU is selected Off

**(5) High Pressure Manifold Indication :**

The pressure indication becomes amber when the pressure ≤ 1450 PSI

*Note : A fixed white RAT indication is displayed.*

**(6) SERVO CTL selector Valves Position Indication :**

	Green	The SERVO CTL selector valve is open
	Amber	The servo CTL selector valve is open and pressure ≤ 1450 PSI
	Amber	The SERVO CTL selector valve is closed

**(7) System Name Indication :**

The indication is white	The associated pressure > 1 740 PSI (if the pressure is increasing) or the associated pressure > 1 450 PSI (if the pressure is decreasing)
The indication is amber	The associated pressure < 1 740 PSI (if the pressure is increasing) or the associated pressure < 1 450 PSI (if the pressure is decreasing)

**(8) HYD Indication :**

The HYD indication is white when the HYD display has been called manually.

The HYD indication is amber when the HYD page is displayed automatically following a warning.

## WARNING LOGIC

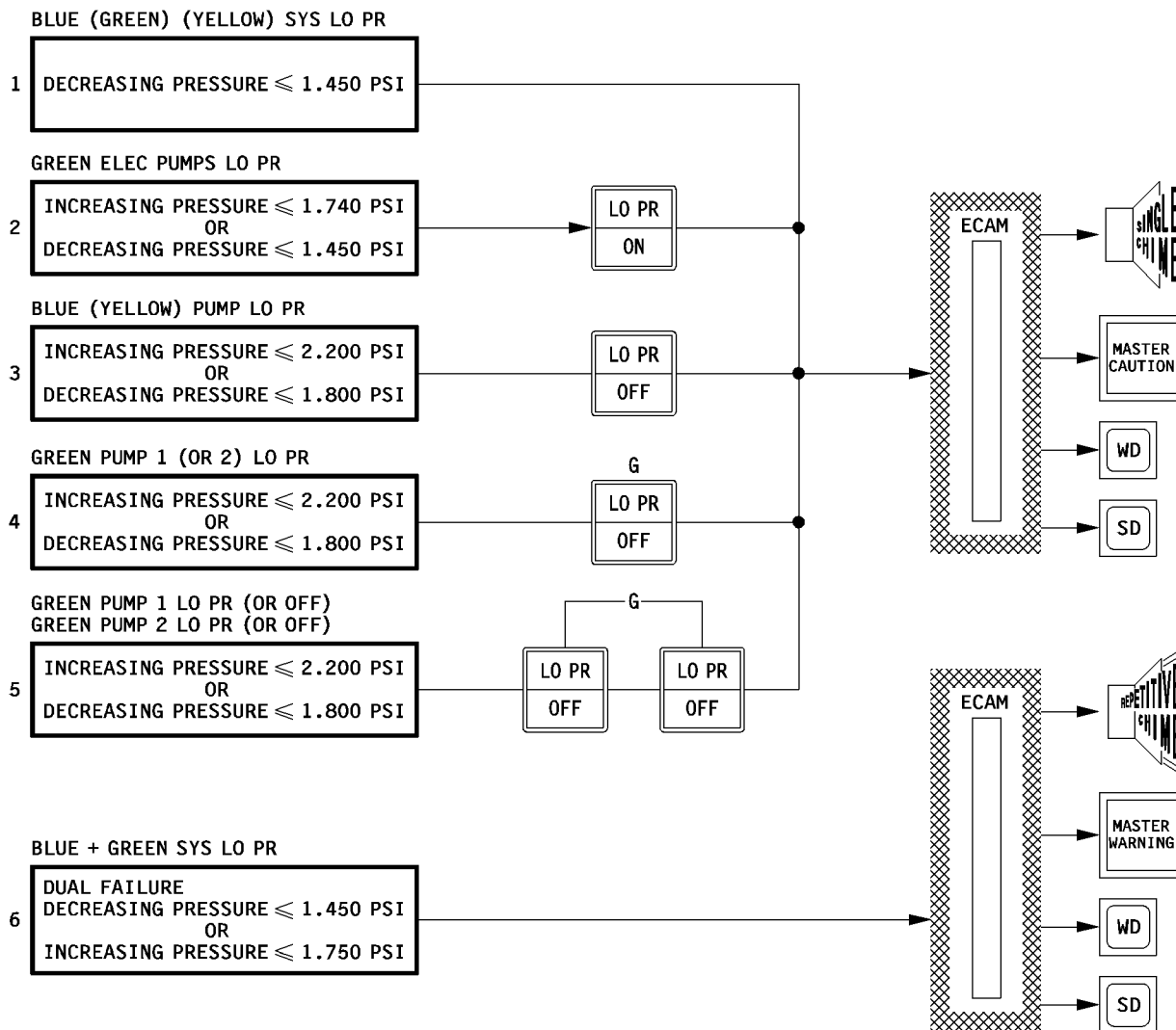

ECAM AUTOMATIC FLIGHT PHASE INHIBITION

B0FC-01-1210-010-A020AA

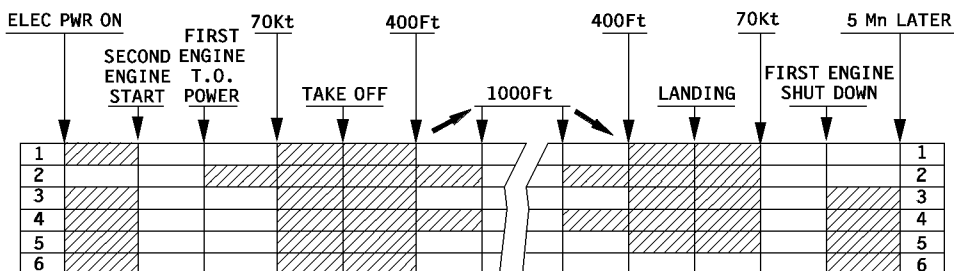

Mod : 5051

### WARNING LOGIC

R

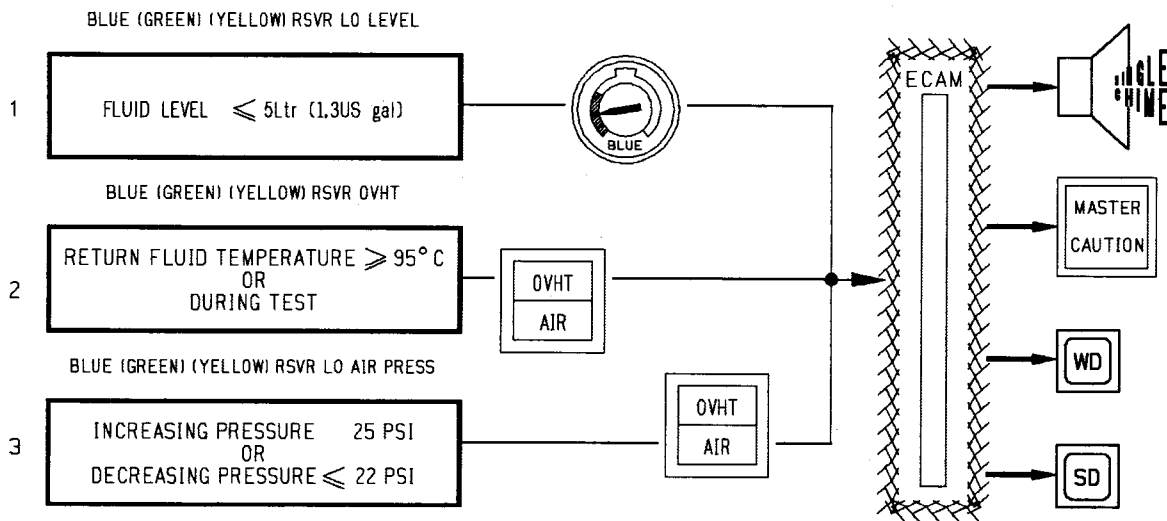

OPS.F.CO.B1.1210.011-AA.020

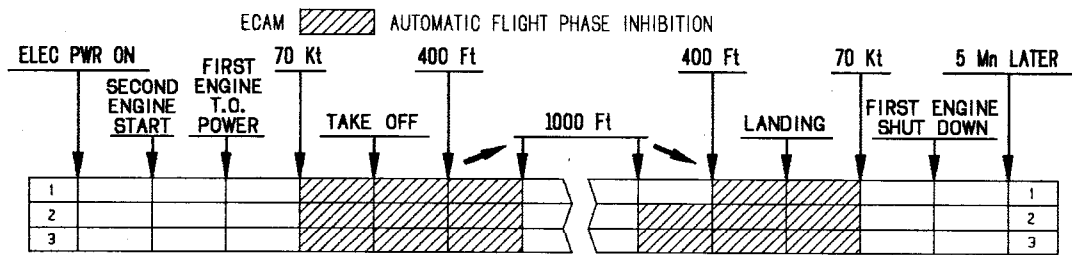

Mod. : 5051

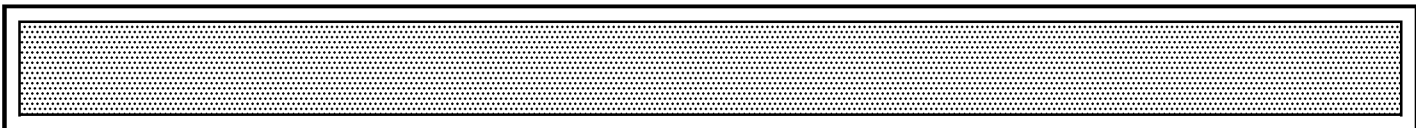

**A – HYD PWR PANEL**

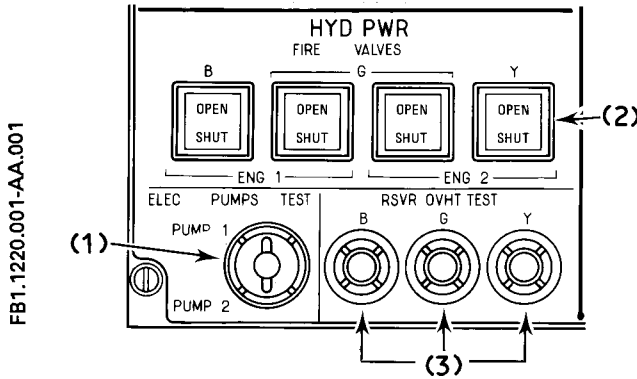

**(3) RSVR OVHT TEST B, G, Y Pushbuttons**

Permit test of hydraulic fluid overheating warning for the individual reservoirs, BLUE, GREEN, YELLOW.

▪ **Pressed**

An overheat signal is simulated in the corresponding overheat detection circuit. If test successful, the respective OVHT light on the HYD PWR section of the overhead panel will come on accompanied by ECAM activation.

▪ **Released**

The overheat signal and the warnings are cancelled.

**(1) ELEC PUMPS TEST Selector**

The selector controls the individual test of the electric pumps in the GREEN system. The selector is springloaded to neutral.

For test, the ELEC PUMPS pushbutton switch on the HYD PWR section of the overhead panel must be selected ON, the ON light on, the LO PR light off.

- **PUMP 1**  
Pump 2 is deactivated by interruption of its electrical supply.  
Pump 1 only is operating.
- **PUMP 2**  
Pump 1 is deactivated by interruption of its electrical supply.  
Pump 2 only is operating.
- **Neutral**  
Both pumps are connected to the electrical supply.

The test of each pump is successful, if the LO PR light in the ELEC PUMPS pushbutton switch does not come on, and the indication on the G PRESS indicator reads approximately 3,000 PSI.

**(2) FIRE VALVES ENG 1, B and G / ENG 2, G and Y Lights**

When the ANN LT selector, on the lateral panel, is set to READ, the FIRE VALVES lights indicate the position of the respective FIRE VALVE, which is controlled by the corresponding ENG FIRE handle.

*Note* : In the yellow system, the valve closes also in case of LO LVL.

- **OPEN**  
Light comes on white, indicating the valve is fully open.
- **SHUT**  
Light comes on white, indicating the valve is fully closed.

