

Engine System Introduction

The following optional engines may be installed on 777 airplanes. General Electric (GE), Pratt and Whitney (PW), and Rolls Royce Trent (RR) model engines are shown. The rated takeoff thrust in pounds for each engine is shown in (parentheses).

- PW4074 (74,500)
- PW4077 (77,200)
- PW4084 (84,000)
- PW4090 (90,000)
- PW4098 (98,000)
- GE90–76B (76,400)
- GE90–77B (77,400)
- GE90–85B (85,000)
- GE90–90B (90,000)
- GE90–94B (94,000)
- GE90–110B1 (110,000)
- GE90–115B (115,000)
- RR Trent 875 (73,400)
- RR Trent 877 (76,900)
- RR Trent 884 (84,000)
- RR Trent 892 (90,000)
- RR Trent 895 (93,400)

[PW, GE Engines]

The engines are dual rotor axial flow turbofans of high compression and bypass ratio. The N1 rotor consists of a fan, a low pressure compressor section, and a low pressure turbine section on a common shaft. The N2 rotor consists of a high pressure compressor section and a high pressure turbine section on a common shaft. The N1 and N2 rotors are mechanically independent. The N2 rotor drives the engine accessory gearbox.

[RR Engines]

The engines are three-rotor axial flow turbofans of high compression and bypass ratio. The N1 rotor consists of the fan and a low pressure turbine section on a common shaft. The N2 rotor consists of an intermediate pressure compressor section and an intermediate pressure turbine section on a common shaft. The N3 rotor consists of a high pressure compressor section and a high pressure turbine section on common shaft. The N1, N2, and N3 rotors are mechanically independent. The N3 rotor drives the engine accessory gearbox.

Each engine is controlled by an electronic engine controller (EEC). The EECs monitor autothrottle and flight crew inputs through the thrust levers to automatically control the engines.

Each engine has individual flight deck controls. Thrust is set by positioning the thrust levers. The thrust levers are positioned automatically by the autothrottle system or manually by the flight crew.

Engine indications are displayed on the engine indication and crew alerting system (EICAS) display.

Engine Intermix

[GE Engines]

Both engines are set to operate at the same thrust rating. Replacement engine thrust rating is increased or decreased to match the thrust rating of the installed engine configuration. An EGT amber band (maximum continuous limit) difference between engines may be indicated, but these indications are normal.

[PW Engines]

Both engines are set to operate at the same thrust rating. Replacement engine thrust rating is increased or decreased to match the thrust rating of the installed engine configuration. An EGT red line (maximum takeoff EGT limit) difference between the engines may be indicated, but these indications are normal.

Takeoff Bump Thrust Reference Mode

[Option]

Takeoff bump (when use is approved) can be selected on the CDU THRUST LIM page. When selected, TO B is displayed as the EICAS thrust reference mode.

Takeoff bump thrust is also available whenever the airplane is in the takeoff bump region (altitude and ambient temperature range). If the thrust levers are manually positioned full forward while in the takeoff bump region, the EECs will allow thrust to increase up to the takeoff bump rating even though another thrust limit is selected on the CDU THRUST LIM page.

Engine Indications

Primary and secondary engine indications are provided. Engine indications are displayed on the EICAS display and any selected multifunction display (MFD).

Primary Engine Indications

[PW, RR Engines]

EPR, N1, and EGT are the primary engine indications. The primary engine indications are always displayed on the EICAS display. Normally the EICAS is on the upper center display unit. If that unit fails the EICAS display automatically moves to the lower center display unit.

[GE Engines]

N1 and EGT are the primary engine indications.

The primary engine indications are always displayed on the EICAS display.

Normally the EICAS is on the upper center display unit. If that unit fails, the EICAS display automatically moves to the lower center display unit.

Secondary Engine Indications

[PW, GE Engines]

N2, fuel flow, oil pressure, oil temperature, oil quantity, and engine vibration are secondary engine indications. Secondary engine indications are displayed on the selected MFD. The secondary engine indications can be displayed by pushing the secondary engine display switch (the ENG switch on the display select panel). The secondary engine indications are automatically displayed when:

- the displays initially receive electrical power
- a FUEL CONTROL switch is moved to CUTOFF in flight
- an engine fire switch is pulled in flight
- a secondary engine parameter is exceeded, or
- engine N2 RPM is below idle in flight.

[RR Engines]

N2, N3, fuel flow, oil pressure, oil temperature, oil quantity, and engine vibration are secondary engine indications. Secondary engine indications are displayed on the selected MFD. The secondary engine indications can be displayed by pushing the secondary engine display switch (the ENG switch on the display select panel). The secondary engine indications are automatically displayed when:

- the displays initially receive electrical power
- a FUEL CONTROL switch is moved to CUTOFF in flight
- an engine fire switch is pulled in flight
- a secondary engine parameter is exceeded, or
- engine N3 RPM is below idle in flight.

When the secondary engine parameters are automatically displayed (on the lower MFD, if available) due to any of the above conditions, they cannot be cleared until the condition is no longer present. Once the condition is no longer present, the secondary engine parameters can be cleared by pushing the secondary engine display switch.

Normal Display Format

[PW, GE Engines]

Primary engine indications and the N2 indications are both digital readouts and round dial/moving pointer indications. The digital readouts display numerical values while the moving pointers indicate relative value.

[RR Engines]

Primary engine indications and the N3 indication are digital readouts and round dial/moving pointer indications. The digital readouts display numerical values while the moving pointers indicate relative value.

[PW, GE Engines]

Oil pressure, oil temperature, and vibration indications are both digital readouts and vertical indication/moving pointers. Fuel flow and oil quantity are digital readouts only. All digital readouts are enclosed by boxes. The dial and vertical indications display the normal operating range, caution range, and operating limits (as applicable).

[RR Engines]

Oil pressure, oil temperature, and vibration indications are both digital readouts and vertical indication/moving pointers. Fuel flow, N2, and oil quantity are digital readouts only. All digital readouts are enclosed by boxes. The dial and vertical indications display the normal operating range, caution range, and operating limits (as applicable).

Normal operating range is displayed on a dial or vertical indication in white.

[PW Engines]

The oil temperature vertical indication has caution ranges displayed by amber bands. If oil temperature reaches the caution range, the digital readout, digital readout box, and pointer all change color to amber.

[GE, RR Engines]

The oil temperature and oil pressure vertical indication has caution ranges displayed by amber bands. If oil temperature or oil pressure reaches the caution range, the digital readout, digital readout box, and pointer all change color to amber.

[PW, GE Engines]

N1, N2, EGT, oil pressure, and oil temperature indications have operating limits indicated by red lines. If one of these indications reaches the red line, the digital readout, box, and pointer change color to red for that indication.

[RR Engines]

N1, EGT, N3, oil pressure, and oil temperature indications have operating limits indicated by red lines. If one of these indications reaches the red line, the digital readout, box, and pointer change color to red for that indication.

[Option – 5 Minute Takeoff Inhibit]

The EGT indication has a maximum continuous limit represented by an amber band. The maximum continuous limit does not apply during takeoff or go-around. If EGT reaches the maximum continuous limit, the digital indication, box, pointer, and dial all change color to amber. EGT indications are inhibited from changing to amber during takeoff or go-around for five minutes. The EGT indication is often in the amber band during takeoff; this is acceptable. The EGT indication has a maximum takeoff limit displayed by a red line. If EGT reaches the maximum takeoff limit, the digital indication, box, pointer and dial, all change color to red.

[Option – 10 Minute Takeoff Inhibit]

The EGT indication has a maximum continuous limit represented by an amber band. The maximum continuous limit does not apply during takeoff or go-around. If EGT reaches the maximum continuous limit, the digital indication, box, pointer, and dial all change color to amber. EGT indications are inhibited from changing to amber during takeoff or go-around for five minutes. The EGT indication is often in the amber band during takeoff; this is acceptable. The inhibit is extended to ten minutes for single-engine operation. The EGT indication has a maximum takeoff limit displayed by a red line. If EGT reaches the maximum takeoff limit, the digital indication, box, pointer and dial, all change color to red.

[PW, GE Engines]

If an N1, N2, or EGT red line is exceeded, the box enclosing the digital readout remains red after the exceeded limit returns to the normal range. The red box color can be canceled to white or recalled to red by pushing the cancel/recall switch on the display select panel. An indication changes color back to white when it returns to the normal operating range.

[RR Engines]

If an N1, N3, or EGT red line is exceeded, the box enclosing the digital readout remains red after the exceeded limit returns to the normal range. The red box color can be canceled to white or recalled to red by pushing the cancel/recall switch on the display select panel. An indication changes color back to white when it returns to the normal operating range.

For low oil quantity, the oil quantity digital readout changes to black text on a white background. The white text LO is displayed adjacent to the readout.

For high engine vibration, the vibration digital readout changes to black text on a white background.

[PW, RR Engines]

The maximum EPR limit is indicated by an amber line at the top of the EPR dial. The EPR indication does not change color when maximum EPR is reached. The reference/target EPR indication displays the FMS reference or target EPR. The commanded EPR indication displays the EEC calculated EPR commanded by thrust lever position.

Compact Display Format

[PW Engines]

In compact format, primary and secondary engine indications are combined on the same display. The EPR and N1 displays are the same as the normal displays. All other indications change to digital readouts only. If an amber or red line parameter for a digital indication is exceeded, the digital indication changes color to amber or red (as does the box that appears around an EGT, or N2 indication for a red line exceedance). If the EGT or N2 red line is exceeded, the red color of the box around the digital indication can be returned to white (if the exceeded parameter has returned to normal) by pushing the display select panel CANCEL/RECALL switch.

[GE Engines]

In compact format, primary and secondary engine indications are combined on the same display. The N1 and EGT indications are displayed as they are normally (moving pointer/round dial and digital indications). All other indications change to digital readouts only, with the exception that the N2 digital readout is boxed if a parameter is exceeded. If an amber or red line parameter for a digital indication is exceeded, the digital indication changes color to amber or red (as does the box that appears around the N2 indication for a red line exceedance). If the N2 red line is exceeded, the red color of the box around the digital indication can be returned to white (if the exceeded parameter has returned to normal) by pushing the display select panel CANCEL/RECALL switch.

[RR Engines]

In compact format, primary and secondary engine indications are combined on the same display. The EPR and N1 displays are the same as the normal displays. All other indications change to digital readouts only. If an amber or red line parameter for a digital indication is exceeded, the digital indication changes color to amber or red (as does the box that appears around an EGT, N2, or N3 indication). If the N1, N2, N3, or EGT red line is exceeded, the red color of the box around the digital indication can be returned to white (if the exceeded parameter has returned to normal) by pushing the display select panel CANCEL/RECALL switch.

Primary and secondary engine indications are displayed on EICAS in compact format whenever:

- secondary engine display is automatically selected, and the lower multifunction display is failed, unpowered, or is occupied, or
- secondary engine display is manually selected to the lower center MFD and the lower MFD is failed, unpowered, or occupied with EICAS.

Electronic Engine Control (EEC)

[PW, RR Engines]

Each EEC has full authority over engine operation. The EEC uses thrust lever inputs to automatically control forward thrust and reverse thrust. The EEC has two control modes: normal and alternate. In the normal mode, the EEC uses EPR as the parameter for setting thrust. In the alternate mode, the EEC uses N1 RPM as the controlling parameter.

[PW Engines]

At altitudes of 17,000 feet and above, compressor stall protection logic causes the engines to accelerate slowly if the acceleration is initiated shortly after a deceleration. The engines may accelerate at slightly different rates. Thrust asymmetry compensation (TAC) may activate.

[GE Engines]

Each EEC has full authority over engine operation. The EEC uses thrust lever inputs to automatically control forward thrust and reverse thrust. The EEC has two control modes: normal and alternate. In both normal and alternate modes, the EEC uses N1 RPM as the parameter for setting thrust.

EEC Normal Mode

[PW, RR Engines]

In the normal mode, the EEC sets thrust by controlling EPR based on thrust lever position. EPR is commanded by positioning the thrust levers either automatically with the autothrottles, or manually by the flight crew.

[GE Engines]

In the normal mode, the EEC sets thrust by controlling N1 based on thrust lever position. N1 is commanded by positioning the thrust levers either automatically with the autothrottles, or manually by the flight crew.

[PW, RR Engines]

Maximum EPR represents the maximum rated thrust available from the engine. The EEC continuously computes maximum EPR.

[GE Engines]

Maximum N1 represents the maximum rated thrust available from the engine. The EEC continuously computes maximum N1.

Maximum rated thrust is available in any phase of flight by moving the thrust levers to the full forward positions.

EEC Alternate Mode

If the required signals are not available to operate in the normal mode, the EEC automatically uses the alternate mode. In the alternate mode, the EEC schedules N1 as a function of thrust lever position. The alternate mode provides soft and hard levels of control:

- **Soft** – When the EEC automatically switches an engine to the alternate mode and the EEC mode switch remains in NORM, the EEC is in the soft alternate mode (the switch position is NORM, the EEC mode is alternate). At a fixed thrust lever position, thrust does not change.
- **Hard** – When ALTN is manually selected on an EEC mode switch, that engine is switched to the hard alternate mode (the switch position is ALTN, the EEC mode is alternate). Reference and target N1, and maximum and commanded N1 values are displayed on the N1 indication during the hard alternate mode. Thrust may change to set the commanded N1 when ALTN is manually selected.

[PW, RR Engines]

For the normal, soft alternate, and hard alternate modes, the following EPR and N1 information is displayed:

EEC mode switch – NORM EEC mode – Normal	EEC mode switch – NORM EEC mode – Soft Alternate	EEC mode switch – ALTN EEC mode – Hard Alternate
<ul style="list-style-type: none"> • EPR: actual, command, reference/target, maximum • N1: actual, red line. 	<ul style="list-style-type: none"> • EPR: blank • N1: actual, red line. 	<ul style="list-style-type: none"> • EPR: blank • N1: actual, command, reference/target, maximum, red line.

[GE Engines]

For the normal, soft alternate, and hard alternate modes, actual, command, reference/target, maximum, and red line N1 information is displayed.

Automatic reversion or manual selection to the alternate mode is indicated by the EICAS advisory message ENG EEC MODE (L, R) and illumination of the EEC alternate (ALTN) light on the associated EEC mode switch. Selecting the alternate mode on both engines eliminates thrust lever stagger at equal thrust settings, or asymmetric thrust when the thrust levers are operated together.

The autothrottles remain engaged whenever the EEC automatically switches to the alternate mode. The alternate mode N1 reference/target values are computed by the FMC.

Note: Autothrottles remains engaged in the soft or hard alternate mode.

The alternate mode schedule (N1 schedule) provides equal or greater thrust than the normal mode for the same thrust lever position.

Thrust protection is not provided in the alternate mode and maximum rated thrust is reached at a thrust lever position less than full forward. As a result, thrust overboost can occur at full forward thrust lever positions. The EICAS caution message ENG LIMIT PROT (L, R) is displayed if the thrust lever position commands an N1 greater than the maximum rated thrust (maximum N1). N1 and N2 red line protection is still available in the alternate control mode.

Overspeed Protection

[Option PW, GE Engines]

The EEC also provides N1 and N2 red line overspeed protection. If N1 or N2 approaches overspeed, the EEC commands reduced fuel flow. The EICAS advisory message ENG RPM LIMITED (L or R) is provided when overspeed protection is provided.

[Option RR Engines]

The EEC also provides N1, N2, and N3 red line overspeed protection. If N1, N2, or N3 approaches overspeed, the EEC commands reduced fuel flow. The EICAS advisory message ENG RPM LIMITED (L or R) is provided when overspeed protection is provided.

If the EECs are in alternate mode, advancing the thrust levers full forward provides some overboost and should be considered only during emergency situations when all other available actions have been taken and terrain contact is imminent.

EEC Idle Selection

The EEC selects minimum idle or approach idle automatically. Minimum idle is a lower thrust than approach idle. Approach idle is selected in flight if:

- engine anti-ice is operating
- the flaps are commanded to 25 or greater
- one hydraulic system air-driven demand pump is inoperative, and the flaps are out of the UP position
- the opposite engine bleed air valve is closed

Approach idle decreases acceleration time for go-around. Approach idle is maintained until after touchdown, when minimum idle is selected.

Engine Start and Ignition System

The engines can be started using the autostart system or manually. Autostart is the normal starting mode. Selecting OFF on the AUTOSTART switch disables autostart and allows manual, pilot-monitored, starting.

[PW, GE Engines]

Bleed air powers the starter motor, which is connected to the N2 rotor. The starter air source is normally the APU, but air from ground carts or another running engine can be used.

[RR Engines]

Bleed air powers the starter motor, which is connected to the N3 rotor. The starter air source is normally the APU, but air from ground carts or another running engine can be used.

[Option - PW, GE Engines with CON IGN position]

The START/IGNITION selectors control the starter air valves and provide continuous ignition capability. Ignition and fuel flow are controlled through the FUEL CONTROL switches.

[Option - RR Engines, GE Engines without CON IGN position]

The START selectors control the starter air valves. Ignition and fuel flow are controlled through the FUEL CONTROL switches.

[PW Engines]

The EEC monitors the start to determine the optimum N2 RPM for starter cutout. At that RPM, the EEC commands starter cutout, and the START/IGNITION selector releases to the NORM position.

[GE Engines with CON IGN position]

At approximately idle N2 RPM, the EEC commands starter cutout, and the START/IGNITION selector releases to the NORM position.

[RR Engines]

The EEC monitors the start and commands starter cutout at 50 percent N3 RPM. The START selector releases to the NORM position.

[PW, GE Engines]

A maximum start limit line (red) is displayed on the EGT indication when the FUEL CONTROL switch is moved to CUTOFF or engine N2 RPM is below idle. It remains displayed after the FUEL CONTROL switch is moved to RUN until the engine is stabilized at idle. The EGT indication changes color to red if the EGT start limit is reached during starting.

[RR Engines]

A maximum start limit line (red) is displayed on the EGT indication when the FUEL CONTROL switch is moved to CUTOFF or engine N3 RPM is below idle. It remains displayed after the FUEL CONTROL switch is moved to RUN until the engine is stabilized at idle. The EGT indication changes color to red if the EGT start limit is reached during starting.

Autostart

[PW Engines]

Autostart allows the EEC to control fuel and ignition. With the AUTOSTART switch ON, the autostart sequence is initiated by rotating the START/IGNITION selector to START and moving the FUEL CONTROL switch to RUN. For in-flight windmill starts the autostart sequence is initiated by moving the FUEL CONTROL switch to RUN.

The START/IGNITION selector opens the starter air valve to begin dry motoring the engine. Moving the FUEL CONTROL switch to RUN opens the spar fuel valve, but not the engine fuel valve. The proper sequencing of fuel and ignition is controlled by the autostart system. With the FUEL CONTROL switch positioned to RUN, the EEC opens engine fuel metering valve and energizes the igniter(s) at the appropriate N2 RPM.

During autostart, the EEC monitors EGT, N2 RPM, and other engine parameters until the engine reaches idle. During ground start, the autostart system monitors engine parameters and will abort the start for any of the following:

- hot start
- hung start
- no EGT rise
- compressor stall
- starter shaft failure
- no N1 rotation
- insufficient air pressure for starter operation
- start time exceeds the starter duty cycle timer.

Note: The autostart system does not monitor oil pressure and temperature.

If a hot start, hung start/stall, or no light condition is detected, and N2 RPM is less than the starter cutout speed, the EEC turns off fuel and ignition and motors the engine for approximately 30 seconds before making a second attempt. The second attempt uses both igniters. On the ground, if the second attempt fails, the EEC aborts the start. Fuel and ignition are shut off, and the engine is motored for 30 seconds to clear residual fuel. The starter air valve then closes and the START/IGNITION selector releases to the NORM position. The EICAS caution message ENG AUTOSTART (L or R) is displayed.

On the ground, autostart does not attempt a second start if there is no N1 rotation, insufficient air pressure, the starter shaft fails, the start time exceeds the starter duty cycle, or the start is aborted above starter cutout speed and the EICAS caution message ENG AUTOSTART (L or R) is displayed.

Note: For some conditions, the EEC may rapidly cycle fuel off and on in an attempt to clear the condition.

Note: For in-flight starts, the autostart system discontinues the start temporarily only if the takeoff EGT limit is exceeded. Autostart takes corrective action if some start problems are detected, but does not abort the start.

Whenever the AUTOSTART switch is selected OFF, the EICAS advisory message ENG AUTOSTART OFF is displayed and the AUTOSTART switch OFF light illuminates.

Autostart

[GE Engines with CON IGN position]

Autostart allows the EEC to control fuel and ignition. With the AUTOSTART switch ON, the autostart sequence is initiated by rotating the START/IGNITION selector to START and moving the FUEL CONTROL switch to RUN. For in-flight windmill starts the autostart sequence is initiated by moving the FUEL CONTROL switch to RUN.

The START/IGNITION selector opens the starter air valve to begin dry motoring the engine. Moving the FUEL CONTROL switch to RUN opens the spar fuel valve, but not the engine fuel valve. The proper sequencing of fuel and ignition is controlled by the autostart system. With the FUEL CONTROL switch positioned to RUN, the EEC opens engine fuel valve and energizes the igniter(s) at the appropriate N2 RPM.

During autostart, the EEC monitors EGT, N2 RPM, and other engine parameters until the engine reaches idle. During ground start, the autostart system monitors engine parameters and will abort the start for any of the following:

- hot start
- hung start
- no EGT rise
- compressor stall
- starter shaft failure
- no N1 rotation
- insufficient air pressure for starter operation
- start time exceeds the starter duty cycle timer.

Note: The autostart system does not monitor oil pressure and temperature.

If a hot start, hung start/stall, or no light condition is detected, and N2 is less than starter cutout speed, the EEC turns off fuel and ignition and motors the engine for 6 or 30 seconds (depending on the detected condition) before making a second attempt. The second attempt uses both igniters. If the second attempt fails, a third attempt is made. If N2 is greater than starter cutout speed, the EEC turns off fuel and ignition, closes the starter air valve and allows the engine to spool down below 30 percent N2. It then reopens the starter air valve and motors the engine before re-introducing fuel and ignition for subsequent attempt(s).

On the ground, if all attempts fail, the EEC aborts the start. Fuel and ignition are shut off and the engine is motored to clear residual fuel. The starter air valve then closes and the START/IGNITION selector releases to the NORM position. The EICAS caution message ENG AUTOSTART (L or R) is displayed.

On the ground, autostart does not attempt a second start if there is no N1 rotation, insufficient air pressure, the starter shaft fails, the start time exceeds the starter duty cycle, or the start is aborted above starter cutout speed. The EICAS caution message ENG AUTOSTART (L or R) is displayed.

Note: For in-flight starts, the autostart system temporarily discontinues the start by cutting fuel if a preset EGT between the start and takeoff EGT redline limits is reached, or a hung start is detected. Autostart takes corrective action if some start problems are detected, but does not abort the start.

Whenever the AUTOSTART switch is selected OFF, the EICAS advisory message ENG AUTOSTART OFF is displayed and the AUTOSTART switch OFF light illuminates.

Autostart

[RR Engines]

Autostart allows the EEC to control fuel and ignition. With the AUTOSTART switch ON, the autostart sequence is initiated by rotating the START selector to START and moving the FUEL CONTROL switch to RUN. For in-flight windmill starts the autostart sequence is initiated by moving the FUEL CONTROL switch to RUN.

The START selector opens the starter air valve to begin dry motoring the engine. Moving the FUEL CONTROL switch to RUN opens the spar fuel valve, but not the engine fuel valve. The proper sequencing of fuel and ignition is controlled by the autostart system. With the FUEL CONTROL switch positioned to RUN, the EEC opens engine fuel valve and energizes the igniter(s) above the appropriate N2 and N3 RPM.

During autostart, the EEC monitors EGT, N3 RPM, and other engine parameters until idle N3 RPM is achieved. During ground start, the autostart system monitors engine parameters and will abort the start for any of the following:

- hot start
- hung start
- no EGT rise
- compressor stall
- starter shaft failure
- no N1 rotation
- insufficient air pressure for starter operation
- start time exceeds the starter duty cycle timer.

Note: The autostart system does not monitor oil pressure and temperature.

If a hot start, hung start/stall, or no light condition is detected and N3 RPM is less than starter cutout speed, the EEC turns off fuel and ignition and motors the engine for 20 to 30 seconds (depending on the detected condition). Following motoring and after EGT falls below 100 degrees C, the EEC re-introduces fuel and ignition using both igniters. If the second attempt fails and N3 is less than starter cutout speed, the EEC turns off fuel and ignition and motors the engine for 30 seconds and until the EGT is below 100 degrees C. The starter air valve then closes and the START selector releases to the NORM position. The EICAS caution message ENG AUTOSTART (L or R) is displayed.

If no N1 rotation, low starter air pressure, starter shaft failed condition is detected, if the starter duty cycle timer expires, or the start is aborted above starter cutout speed, the EEC aborts the autostart sequence without motoring and will not make a second attempt. The starter air valve then closes and the START selector releases to the NORM position. The EICAS caution message ENG AUTOSTART (L or R) is displayed.

Note: For in-flight starts, the autostart system temporarily discontinues the start by cutting fuel if the takeoff EGT redline limit is reached, or if a no light-off or a hung start is detected. If one of these conditions is detected, autostart will windmill the engine for 30 seconds before making another attempt. For starter assisted in-flight starts, autostart does not motor the engine with the starter between attempts. Instead, windmill motoring is used and the starter is re-engaged on the following start attempt. Autostart takes corrective action if some start problems are detected, but does not abort the start. During the second or subsequent start attempts autostart re-introduces fuel and ignition when the EGT falls below 200 degrees C.

Whenever the AUTOSTART switch is selected OFF, the EICAS advisory message ENG AUTOSTART OFF is displayed and the AUTOSTART switch OFF light illuminates.

Manual Start

The AUTOSTART switch must be OFF to accomplish a manual start. The start is accomplished in accordance with the Manual Engine Start procedure. Ignition and fuel are provided as soon as the FUEL CONTROL switch is positioned to RUN. The start must be monitored until the engine stabilizes at idle.

[RR Engines]

For ground starts, the FUEL CONTROL switch should not be moved to RUN until EGT is below 100 degrees C.

In-Flight Start

[PW, GE Engines]

In-flight start envelope information is displayed on the EICAS display when an engine is not running in flight (N2 RPM below idle RPM) or when an engine is shut down in flight and the respective engine fire switch is not pulled. The in-flight start envelope indicates the airspeed range necessary to ensure an in-flight start at the current flight level. If the current flight level is above the maximum start altitude, the maximum start altitude and respective airspeed range are displayed.

Secondary engine indications are displayed automatically when a FUEL CONTROL switch is moved to CUTOFF in flight or if N2 RPM goes below idle RPM while in flight. A crossbleed start indication is displayed next to the N2 indication if airspeed is below that recommended for a windmilling start.

For in-flight starts, autostart makes continuous start attempts until the engine either starts or the pilot aborts the start attempt by positioning the FUEL CONTROL switch to CUTOFF (and positioning the start switch to NORM if it was a starter assisted attempt).

In-Flight Start

[RR Engines]

In-flight start envelope information is displayed on the EICAS display when an engine is not running in flight (N3 RPM below idle RPM) or when an engine is shut down in flight and the respective engine fire switch is not pulled. The in-flight start envelope indicates the airspeed range necessary to ensure an in-flight start at the current flight level. If the current flight level is above the maximum start altitude, the maximum start altitude and respective airspeed range are displayed.

Secondary engine indications are displayed automatically when a FUEL CONTROL switch is moved to CUTOFF in flight or if N3 RPM goes below idle RPM while in flight. A crossbleed start indication is displayed next to the N3 indication if airspeed is below that recommended for a windmilling start.

For in-flight starts, autostart makes continuous start attempts until the engine either starts or the pilot aborts the start attempt by positioning the FUEL CONTROL switch to CUTOFF (and positioning the START switch to NORM if it was a starter assisted attempt).

During a windmilling in-flight start, the EEC monitors engine parameters to provide the best fuel schedule to ensure the shortest possible start time.

Engine Ignition

Each engine has two ignitors. The EEC automatically selects the appropriate ignitor(s). The EEC alternates ignitors for successive engine ground starts. Dual ignitors are always used for in-flight starts.

Main AC power is the normal power source for ignition. Standby AC power provides a backup source.

[PW Engines]

By positioning the START/IGNITION selector to CON, continuous ignition is selected. Both ignitors operate continuously when the respective FUEL CONTROL switch is placed to RUN. The ignitors are turned off when the FUEL CONTROL switch is placed to CUTOFF. When the START/IGNITION selector is in the NORM position, continuous ignition is automatically provided whenever:

- the flap lever is out of the UP position, or
- engine anti-ice is on.

[GE Engines with CON IGN position]

By positioning the START/IGNITION selector to CON, continuous ignition is selected. Both ignitors operate continuously when the respective FUEL CONTROL switch is placed to RUN. The ignitors are turned off when the FUEL CONTROL switch is placed to CUTOFF.

Auto-Relight

[PW Engines]

An auto-relight capability is provided for flameout protection. Whenever the EEC detects an engine flameout, both ignitors are activated. A flameout is detected when a rapid decrease in N2 occurs, or N2 is less than idle RPM.

[GE Engines]

An auto-relight capability is provided for flameout protection and sub-idle stall recovery. If the EEC detects an engine flameout, both ignitors activate. A flameout is detected when a rapid decrease in N2 occurs, or N2 is less than idle RPM. If a sub-idle stall is detected, fuel is shut off for one second in an attempt to clear the stall.

[RR Engines]

There is no manual continuous ignition selection or automatic continuous ignition function. Engine flameout protection is provided for an auto-relight and rain/hail ingestion. The auto-relight function is activated whenever an engine is at or below idle with the FUEL CONTROL switch in RUN. When the EEC detects an engine flameout, the respective engine ignitors are activated. If the engine does not recover and continues to run down below 35% N3, the EEC shuts off fuel and ignition and disables the auto-relight function.

The EEC also provides protection against flameout during periods of excessive rain/hail ingestion. When a flameout is detected, the EEC energizes both ignitors.

Engine Start and Ignition System Schematic

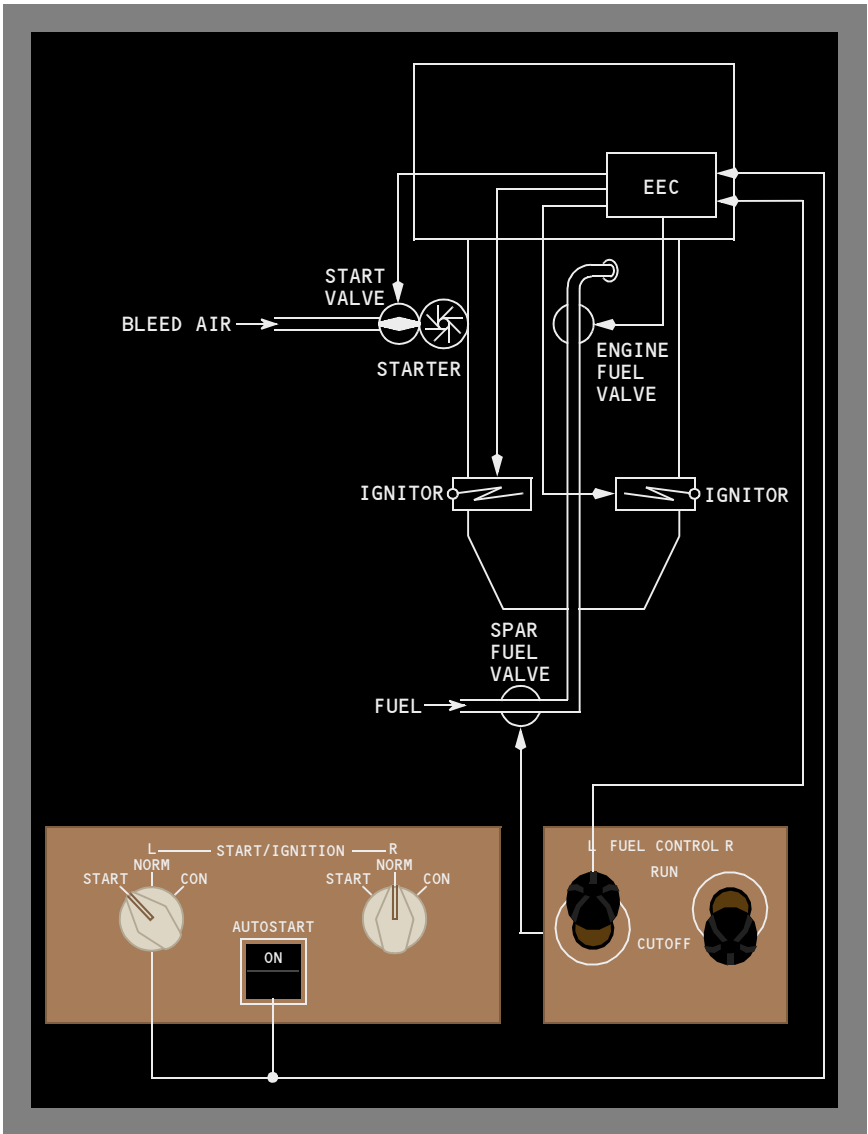

Engine Fuel System

[PW, RR Engines]

Fuel is supplied by fuel pumps located in the fuel tanks. The fuel flows through a spar fuel valve located in the main tank. It then passes through the first stage engine fuel pump where additional pressure is added. It flows through a fuel/oil heat exchanger where it is preheated. A fuel filter removes contaminants. The second stage of the engine fuel pump adds more pressure before the fuel reaches the fuel metering unit. The fuel metering unit adjusts fuel flow to meet thrust requirements. The fuel then flows through the engine fuel valve into the engine.

[GE Engines]

Fuel is supplied by fuel pumps located in the fuel tanks. The fuel flows through a spar fuel valve located in the main tank. It then passes through the first stage engine fuel pump where additional pressure is added. The second stage of the engine fuel pump adds more pressure. It flows through a fuel/oil heat exchanger where it is preheated. A fuel filter removes contaminants. The fuel then reaches the fuel metering unit. The fuel metering unit adjusts fuel flow to meet thrust requirements. The fuel then flows through the engine fuel valve into the engine.

The spar and engine fuel valves allow fuel flow to the engine when both valves are open. The valves open when the engine fire switch is IN and the FUEL CONTROL switch is in RUN. Both valves close when either the FUEL CONTROL switch is in CUTOFF or the engine fire switch is OUT.

Fuel flow is measured after passing through the engine fuel valve. Fuel flow is displayed on the secondary engine display. Fuel flow information is also provided to the FMS.

Engine Fuel System Schematic

[PW, RR Engines]

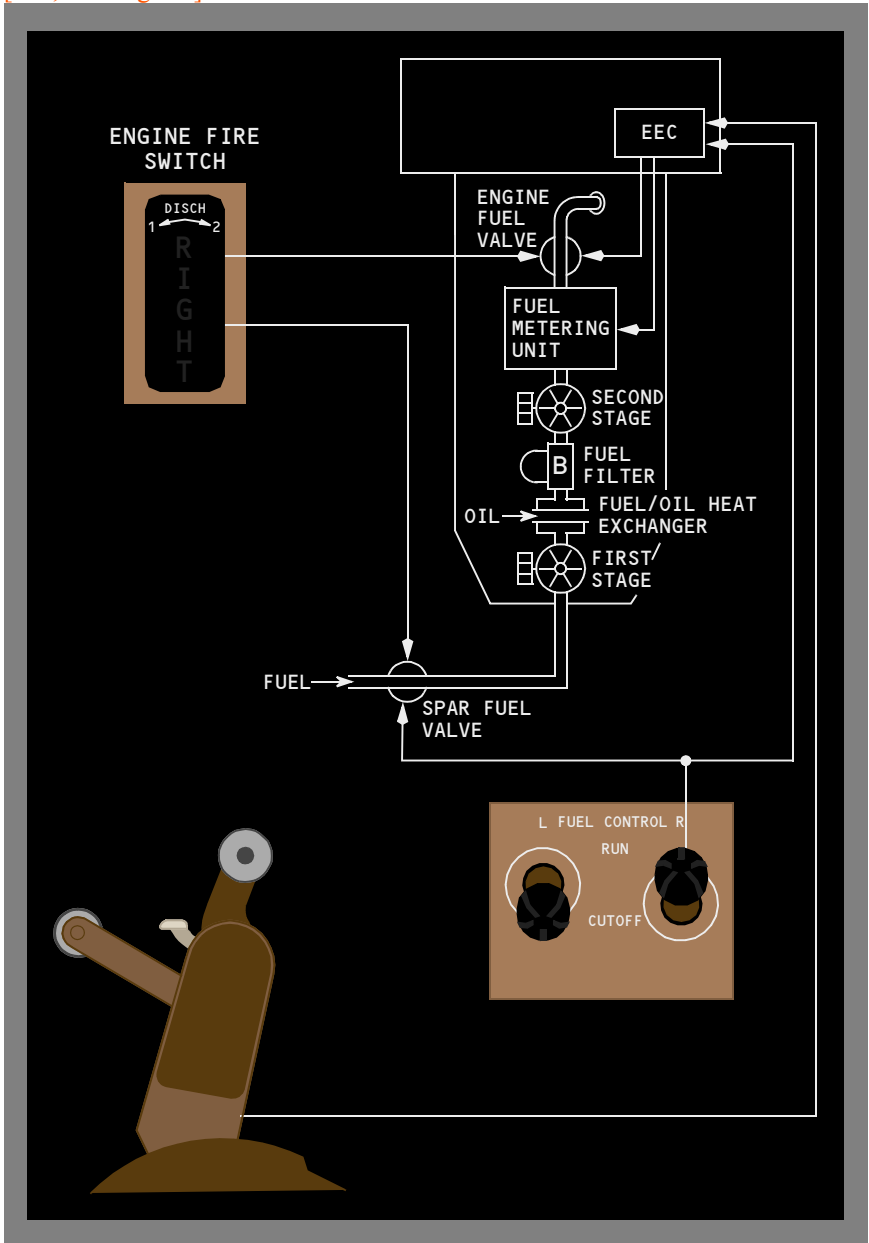

[GE Engines]

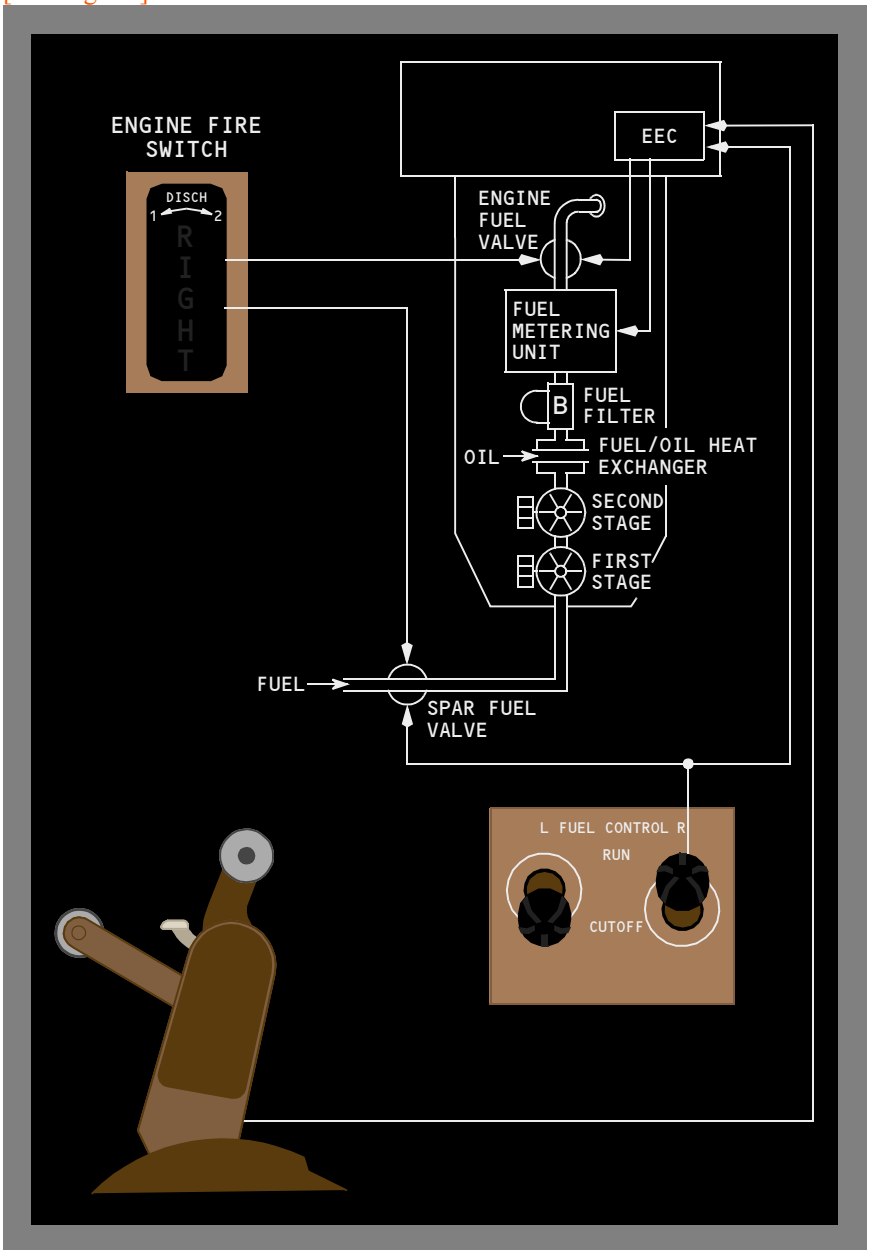

Engine Oil System

The oil system provides pressurized oil to lubricate and cool the engine main bearings, gears and accessory drives. The oil system also provides automatic fuel heating for fuel system icing protection.

[PW Engines]

Oil is pressurized by an engine-driven oil pump. From the pump, the oil flows through a dual oil filter. The oil flows through the air/oil heat exchanger, and fuel/oil heat exchangers and is then delivered to the engine main bearings, gears, and accessory drives. A scavenge pump returns the oil to the reservoir.

[GE Engines]

Oil is pressurized by an engine-driven oil pump. From the pump, the oil flows through the oil filter. If the oil filter becomes clogged, then oil bypasses the oil filter and the EICAS advisory message ENG OIL FILTER (L, R) is displayed. The oil flows through the fuel/oil heat exchangers and then through the backup generator oil/oil heat exchanger, and is then delivered to the engine main bearings, gears, and accessory drives. A scavenge pump returns the oil to the reservoir.

[RR Engines]

Oil is pressurized by an engine-driven oil pump. From the pump, the oil flows through the high pressure oil filter. The oil flows through the air/oil heat exchanger, and fuel/oil heat exchangers and is then delivered to the engine main bearings, gears, and accessory drives. A scavenge pump returns the oil to the reservoir. Prior to the reservoir, the oil flows through a scavenge oil filter. If the scavenge oil filter becomes clogged, then oil bypasses the filter.

[GE Engines]

Oil pressure, temperature, and quantity are displayed on the secondary engine display. Oil pressure and oil temperature are measured prior to entering the engine.

[PW, RR Engines]

Oil pressure, temperature, and quantity are displayed on the secondary engine display. Oil pressure is measured prior to entering the engine. Oil temperature is measured after leaving the engine, prior to entering the reservoir.

There is no minimum oil quantity limit (no amber or red line limit); however, a low oil quantity causes automatic display of the secondary engine display and reverses the display indication to show black numbers on a white background. There are no operating limitations for the engine oil quantity; therefore, there are no flight crew procedures based solely on a response to low oil quantity.

Engine Oil System Schematic

[PW Engines]

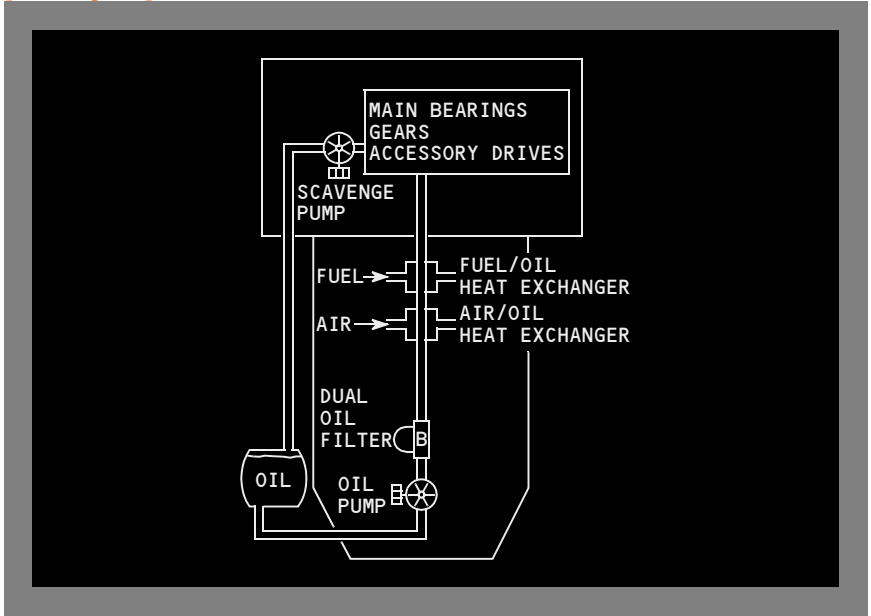

[GE Engines]

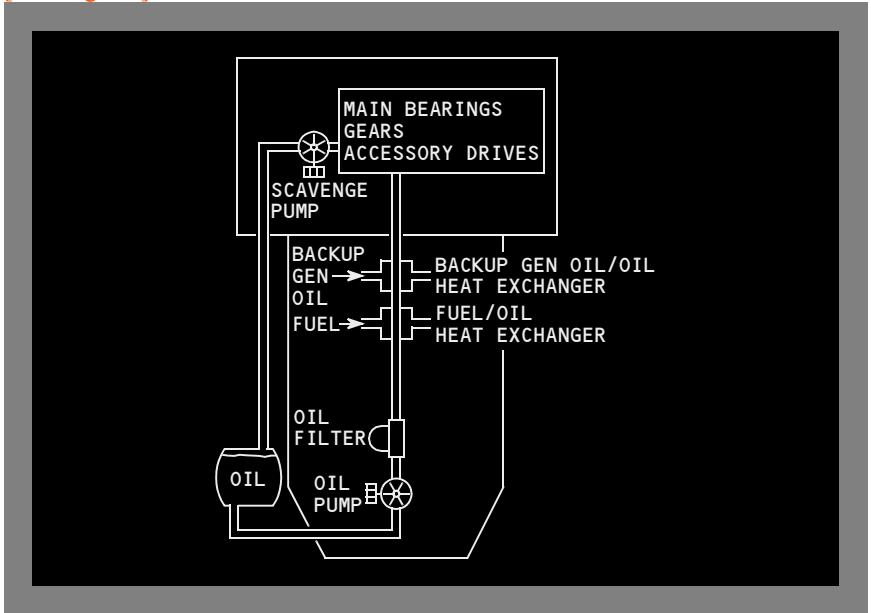

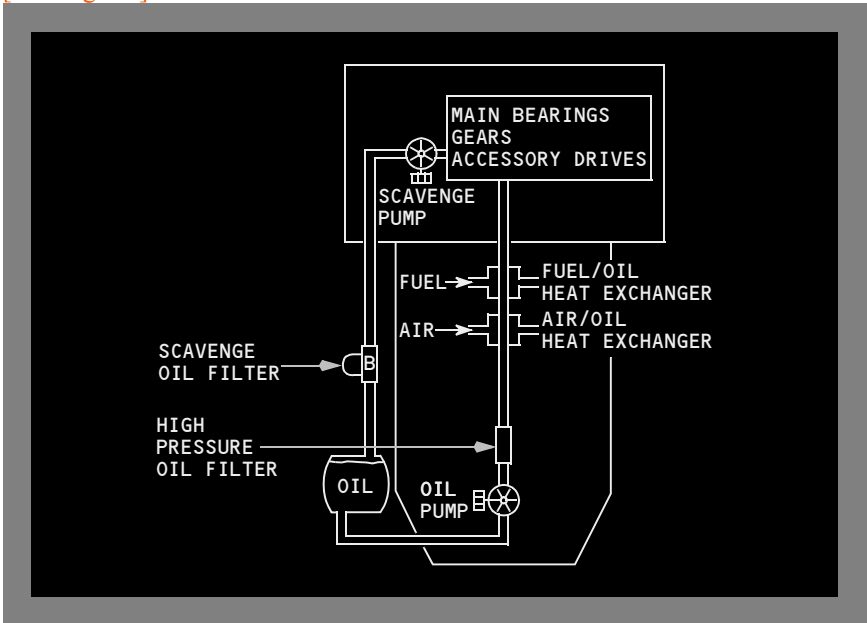
[RR Engines]**Thrust Reverser System**

Each engine has an hydraulically actuated fan air thrust reverser. Reverse thrust is available only on the ground.

The reverse thrust levers can be raised only when the forward thrust levers are in the idle position. When the reverse thrust levers are raised, the EEC opens the reverser isolation valve. The EEC inhibits reverser isolation valve actuation and reverser deployment unless the airplane is on the ground with the engine running. The EECs also control thrust limits during reverser operation.

When the reverse thrust levers are pulled aft to the interlock position:

- the autothrottle disengages
- the auto speedbrakes deploy.

[PW, RR Engines]

When the reverser system is activated:

- the reverser translating sleeves hydraulically move aft
- the fan flow blocker doors rotate into place to direct fan air through stationary cascade guide vanes
- the reverser indication (REV) is displayed above each digital EPR indication (REV is displayed in amber when the reverser is in transit).

[GE Engines]

When the reverser system is activated:

- the reverser translating sleeves hydraulically move aft
- the fan flow blocker doors rotate into place to direct fan air through stationary cascade guide vanes
- the reverser indication (REV) is displayed above each digital N1 indication (REV is displayed in amber when the reverser is in transit).

When the interlock releases:

- the reverse thrust levers can be raised to the maximum reverse thrust position
- the REV indication changes to green when the reverser is fully deployed.

Pushing the reverse thrust levers to the full down position retracts the reversers to the stowed and locked position. The thrust levers cannot be moved forward until the reverse thrust levers are fully down.

The EICAS advisory message ENG REV LIMITED (L or R) is displayed if the reverser cannot deploy when commanded, or can deploy only with reverse thrust limited to idle. Not all conditions limiting or preventing reverse thrust can be detected before reverse thrust selection. For these conditions, the reverse thrust levers cannot be moved beyond the interlock position.

The EICAS advisory message ENG REVERSER (L or R) is displayed on the ground to indicate a reverser system fault.

Thrust Reverser Schematic

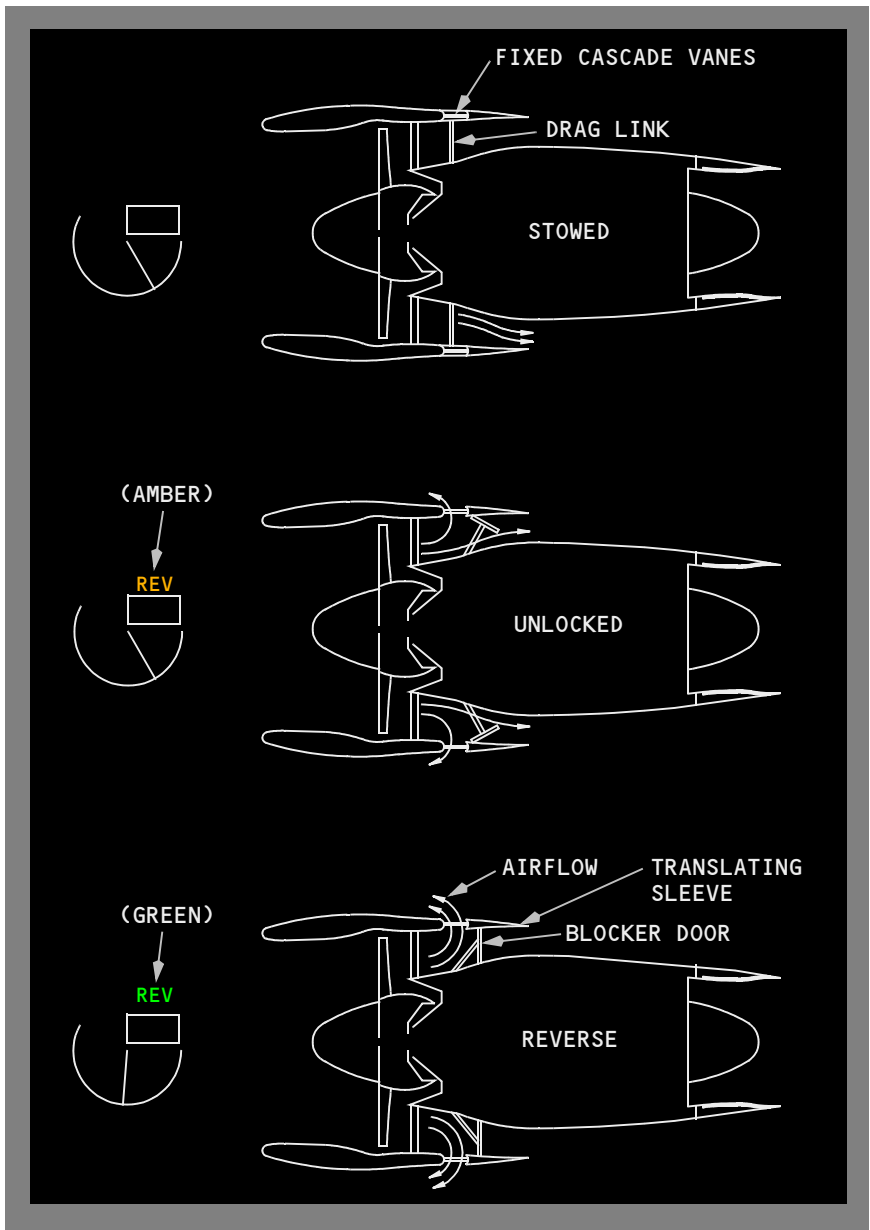

Airborne Vibration Monitoring System

[PW, GE Engines]

The airborne vibration monitoring system monitors engine vibration levels. The vibration indications are displayed on the secondary engine display. The vibration source indication is also displayed. If the vibration monitoring system cannot determine the source (N1 or N2), broadband (BB) is displayed for the affected engine. Broadband vibration is the average vibration detected.

[PW, GE Engines]

The airborne vibration monitoring system is primarily intended for engine condition monitoring, but it is also a useful tool for isolating and determining corrective action for engine anomalies. There is no certified vibration limit, but when a high vibration level is reached, the secondary engine parameters are automatically displayed. Since there are no operating limitations for the airborne vibration monitoring system, there are no specific flight crew actions (or procedures) based solely on vibration indication. High N1 vibration indication would most likely be accompanied by tactile vibration. This is not the case with high N2 vibration indication. Both N1 and N2 high vibrations may be accompanied by anomalies in other engine parameters and will usually respond to thrust lever adjustment.

[RR Engines]

The airborne vibration monitoring system monitors engine vibration levels. The vibration indications are displayed on the secondary engine display. The vibration source indication is also displayed. If the vibration monitoring system cannot determine the source (N1, N2 or N3), broadband (BB) is displayed for the affected engine. Broadband vibration is the average vibration detected.

[RR Engines]

The airborne vibration monitoring system is primarily intended for engine condition monitoring, but it is also a useful tool for isolating and determining corrective action for engine anomalies. There is no certified vibration limit, but when a high vibration level is reached, the secondary engine parameters are automatically displayed. Since there are no operating limitations for the airborne vibration monitoring system, there are no specific flight crew actions (or procedures) based solely on vibration indication. High N1 vibration indication would most likely be accompanied by tactile vibration. This is not the case with high N2 or N3 vibration indication. N1, N2, and N3 high vibrations may be accompanied by anomalies in other engine parameters and will usually respond to thrust lever adjustment.

[All Engines]

Certain engine malfunctions can result in airframe vibrations from the windmilling engine. As the airplane transitions from cruise to landing, there can be multiple, narrow regions of altitudes and airspeeds where the vibration level can become severe. In general, airframe vibrations can best be reduced by descending and reducing airspeed. However, if after descending and reducing airspeed, the existing vibration level is unacceptable, and if it is impractical to further reduce airspeed, the vibration level may be reduced to a previous, lower level by a slight increase in airspeed.

Engine Failure Alert System

The engine failure alert system provides alerts when actual engine performance is less than commanded engine performance during a part of the takeoff and for other phases of flight.

A red ENG FAIL is displayed on the PFD if actual thrust is less than commanded thrust during takeoff with airspeed between 65 knots and 6 knots prior to V1. The PFD display is accompanied by the voice annunciation ENGINE FAIL and the Master WARNING lights illuminating.

The EICAS caution message ENG FAIL (L or R) is displayed if an engine unexpectedly decelerates to less than idle speed. The message remains displayed until the engine recovers or the fuel control switch is moved to CUTOFF.

The EICAS caution message ENG THRUST (L or R) is displayed if:

- actual thrust is significantly less than commanded thrust
- actual thrust is not increasing to commanded thrust, and
- airspeed is V1 or greater

APU Introduction

The auxiliary power unit (APU) is a self-contained gas turbine engine located in the airplane tail cone.

The APU can be started and operated to the airplane maximum certified altitude.

The APU supplies bleed air and electrical power. Electrical power has priority over bleed air. Electrical power is available throughout the airplane operating envelope. Bleed air is available at or below 22,000 feet.

APU Operation

APU Start

The APU is started either by an electric start motor or an air turbine starter.

The electric starter is powered by the APU battery. The main airplane battery powers the inlet door, fuel valve, and fire detection system.

The air turbine starter uses engine bleed air or ground cart air to start the APU.

Starter selection is automatic. The air turbine starter has priority over the electric start motor when there is sufficient bleed air duct pressure.

Rotating the APU selector to START begins the automatic start sequence.

APU fuel is supplied from the left fuel manifold by any operating AC fuel pump or the DC fuel pump. With AC power available and the APU selector in the ON position, the left forward fuel pump operates automatically.

If AC power is not available or no AC pump pressurizes the left fuel manifold, the DC pump in the left main tank provides APU fuel. On the ground, the APU can be started with no pumps operating.

When the APU air inlet door reaches the full open position the starter engages. After the APU reaches the proper speed, ignition and fuel are provided. When the APU reaches approximately 50 percent, the starter disengages and ignition is turned off.

If the start fails, the APU shuts down automatically. The EICAS message APU SHUTDOWN is displayed.

APU Automatic Start

In flight, if both AC transfer busses lose power, the APU automatically starts, regardless of APU selector position. The APU can be shut down by positioning the selector to ON, then OFF.

APU Run

The EICAS memo message APU RUNNING is displayed when the APU is operating normally.

APU Shutdown

Rotating the APU selector to OFF begins the shutdown cycle by closing the APU bleed air valve. The APU continues running for a cooldown period. The EICAS memo message APU COOLDOWN is displayed during the cooldown period. When the cooldown period finishes, the APU shuts down.

APU Operating Modes

The APU has attended and unattended operating modes. The attended mode operates when either engine is running or starting, or when the airplane is in flight. The unattended mode operates at all other times on the ground.

APU Attended Mode

In the attended mode, any of the following faults cause the APU to shut down immediately:

- APU fire/inlet overtemperature
- overspeed/loss of overspeed protection
- APU controller failure
- speed droop.

There is no cool down period. The EICAS advisory message, APU SHUTDOWN, displays.

For the following faults, the APU continues to operate and the EICAS message APU LIMIT displays:

- high EGT
- high oil temperature
- low oil pressure.

There is no cooldown period when the APU is shut down after the APU LIMIT message is displayed.

APU Unattended Mode

In the unattended mode, any of the following faults cause the APU to shutdown immediately:

- APU fire/inlet overtemperature
- overspeed/loss of overspeed protection
- high EGT
- low oil pressure
- high oil temperature
- generator oil filter approaching bypass
- intake door failure
- APU controller failure
- speed droop
- no combustion on start
- no acceleration on start.

There is no cooldown period.

Engines, APU EICAS Messages

The following EICAS messages can be displayed.

APU

Message	Level	Aural	Condition
APU COOLDOWN	Memo		APU is in cooldown mode.
APU LIMIT	Caution	Beeper	APU operation has exceeded a limit.
APU RUNNING	Memo		APU running, and not in cooldown mode.
APU SHUTDOWN	Advisory		APU has automatically shut down.

Engine

Control

Message	Level	Aural	Condition
---------	-------	-------	-----------

[Option – GE Engines except 115B]

ENG ANTI-ICE AIR L, R	Advisory		Engine anti-ice capability is degraded.
-----------------------	----------	--	---

ENG CONTROL L, R	Advisory		Fault is detected in the affected engine control system.
ENG EEC MODE L, R	Advisory		Control for the affected engine is operating in alternate mode.
ENG FAIL L, R	Caution	Beeper	Engine speed is below idle.
ENG IDLE DISAGREE	Advisory		One engine is at approach idle and the other engine is at minimum idle.
ENG LIMIT PROT L, R	Caution	Beeper	Engine control is operating in the alternate mode and commanded N1 exceeds maximum N1.

ENG REV LIMITED L, R	Advisory		Engine thrust reverser will not deploy or reverse thrust will be limited to idle on landing.
ENG REVERSER L, R	Advisory		Fault is detected in the affected engine reverser system.

[Option – GE or PW Engines]

ENG RPM LIMITED L, R	Advisory		Engine control is limiting affected engine thrust to prevent N1 or N2 from exceeding the RPM operating limit.
----------------------	----------	--	---

[Option – RR Engines]

ENG RPM LIMITED L, R	Advisory		Engine control is limiting affected engine thrust to prevent N1, N2, or N3 from exceeding the RPM operating limit.
----------------------	----------	--	--

ENG SHUTDOWN	Caution		Both engines were shutdown on the ground by the fuel control switches or fire switches.
ENG SHUTDOWN L, R	Caution		Engine was shutdown by the fuel control switch or fire switch.
ENG THRUST L, R	Caution	Beeper	Engine is not producing commanded thrust.

Start

Message	Level	Aural	Condition
ENG AUTOSTART L, R	Caution	Beeper	During a ground start, any of the following conditions occurs: <ul style="list-style-type: none"> autostart did not start the engine fuel control switch is in RUN at low engine RPM with the autostart switch off.
ENG AUTOSTART OFF	Advisory		Engine autostart switch is OFF.
ENG START VALVE L, R	Advisory		Engine start valve is not in commanded position.
ENG STARTER CUTOUT L, R	Caution	Beeper	Start/ignition selector remains in START or engine start valve is open when commanded close.

Ignition

[Options – GE Engines with CON IGN position, PW Engines]

Message	Level	Aural	Condition
CON IGNITION ON L, L+R, R	Memo		Indicates respective engine START/IGNITION selector CON position selected.

Fuel

Message	Level	Aural	Condition
ENG FUEL FILTER L, R	Advisory		An impending fuel filter bypass condition exists on the affected engine.
ENG FUEL VALVE L, R	Advisory		Engine fuel or spar valve position disagrees with commanded position.

Oil

Message	Level	Aural	Condition

[Option – GE Engines]

ENG OIL FILTER L, R	Advisory		Affected engine oil filter contamination has caused filter bypass.
------------------------	----------	--	--

[Option – PW, RR Engines (with PW optional ENG OIL FILTER message)]

ENG OIL FILTER L, R	Advisory		Primary engine oil filter contamination approaching a bypass condition, oil will be filtered through the secondary filter.
------------------------	----------	--	--

ENG OIL PRESS L, R	Caution	Beeper	Engine oil pressure is low.
ENG OIL TEMP L, R	Advisory		Engine oil temperature is high.

EICAS Display

[Options – PW, RR Engines, English Units]

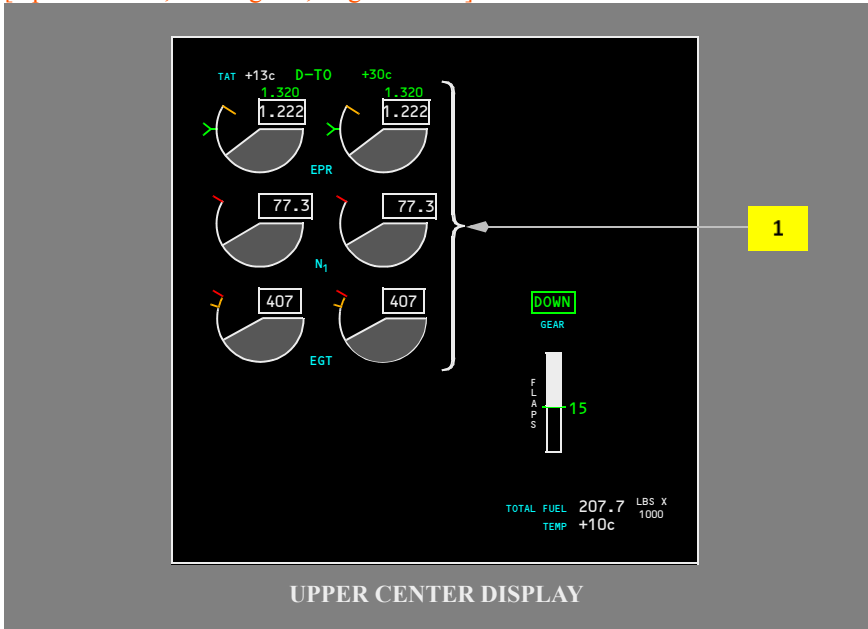

[Options – GE Engines, Metric Units]

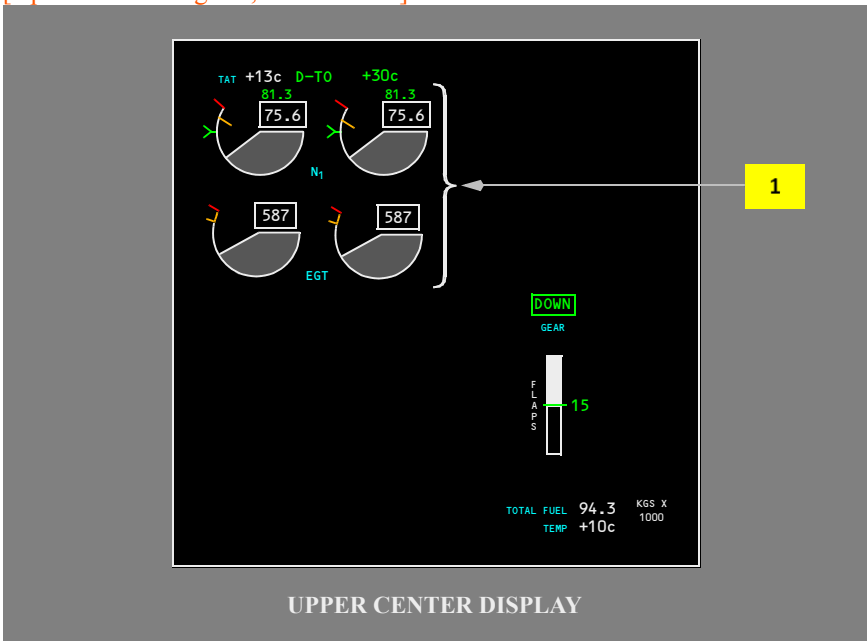

1 Primary Engine Indications

[PW, RR Engines]

Displayed full time on the EICAS display:

- EPR
- N1
- EGT.

1 Primary Engine Indications

[GE Engines]

Displayed full time on the EICAS display:

- N1
- EGT.

Mode Indications

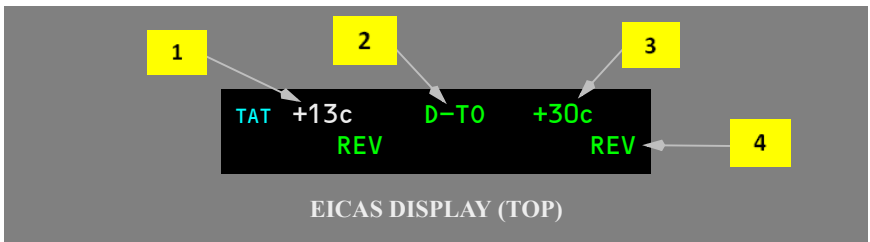

1 Total Air Temperature (TAT)

Displayed (white) – TAT (degrees C).

2 Thrust Reference Mode

[Option – Takeoff Derates]

Displayed (green) – selected FMS thrust reference mode:

- TO – maximum rated takeoff thrust
- TO 1 – derate one takeoff thrust
- TO 2 – derate two takeoff thrust
- D-TO – assumed temperature derated takeoff thrust
- D-TO 1 – derate one assumed temperature derated takeoff thrust
- D-TO 2 – derate two assumed temperature derated takeoff thrust
- CLB – maximum rated climb thrust
- CLB 1 – derate one climb thrust
- CLB 2 – derate two climb thrust
- CON – maximum rated continuous thrust
- CRZ – maximum rated cruise thrust
- G/A – maximum go-around thrust.

[Option]

- TO B – provides additional takeoff thrust. Refer to the Airplane Flight Manual (AFM) for the performance limitations and data required to use this feature.

[Option]

- A-TO, A-TO 1, A-TO 2, A-TO B – APU-to-Pack or APU-to-Pack derated or APU-to-Pack takeoff bump thrust

3 Assumed Temperature

Displayed (green) – selected assumed temperature (degrees C) for reduced thrust takeoff.

4 Thrust Reverser Indication

Displayed REV (amber) – reverser in transit.

Displayed REV (green) – reverser fully deployed.

EPR Indications

[PW, RR Engines]

Note: During tailwind conditions, slight EPR fluctuations may occur prior to 5 knots forward airspeed.

Note: When reverse thrust is activated, the following indications are not displayed:

- maximum EPR line
- commanded EPR
- reference/target EPR indication
- reference EPR.

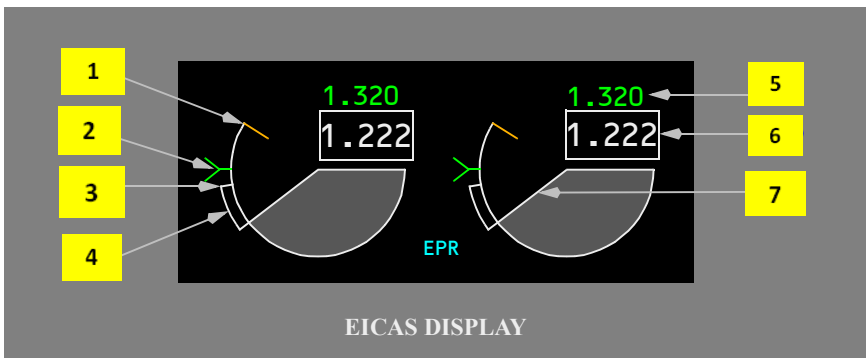

1 Maximum EPR Line

Displayed (amber).

2 Reference/Target EPR indication

Displayed (green) – reference EPR limit.

Displayed magenta – target FMC commanded EPR when VNAV is engaged and:

- the autothrottle is engaged in THR or THR REF mode, or
- the autothrottle is not engaged.

3 Commanded EPR

Displayed (white).

4 Commanded EPR Sector

Displays momentary difference between engine EPR and EPR commanded by thrust lever position.

5 Reference EPR

Displayed (green).

6 Actual EPR

Displayed (white).

7 Actual EPR indication

Displayed (white).

EPR Indications (Alternate Mode)

[PW, RR Engines]

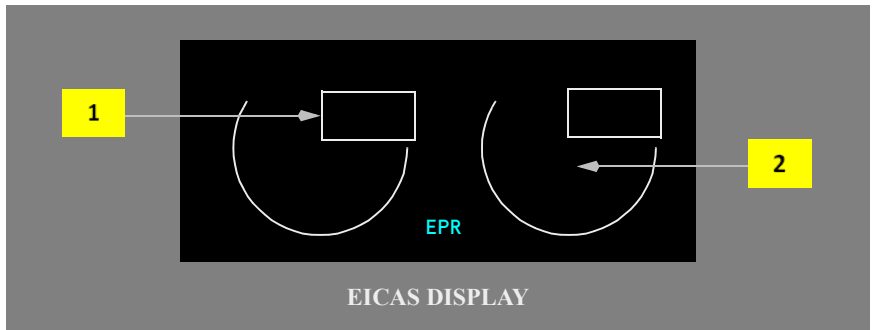

1 EPR Indication

Displayed (blank).

2 Actual EPR Indication

Displayed (blank).

N1 Indications

[PW, RR Engines]

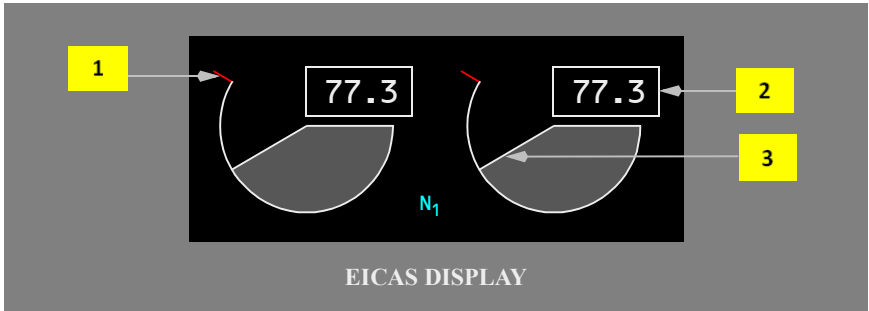

1 N1 Red Line

Displayed (red) – N1 RPM operating limit.

2 N1

Digital N1 RPM (%), displayed:

- (white) – normal operating range
- displayed (red) – operating limit reached.

3 N1 Indication

N1 RPM, displayed:

- (white) – normal operating range
- displayed (red) – operating limit reached.

N1 Indications (Hard Alternate Mode)

[PW, RR Engines]

Note: When reverse thrust is activated, the following indications are not displayed:

- maximum N1 line
- commanded N1
- reference/target N1 indication
- reference N1.

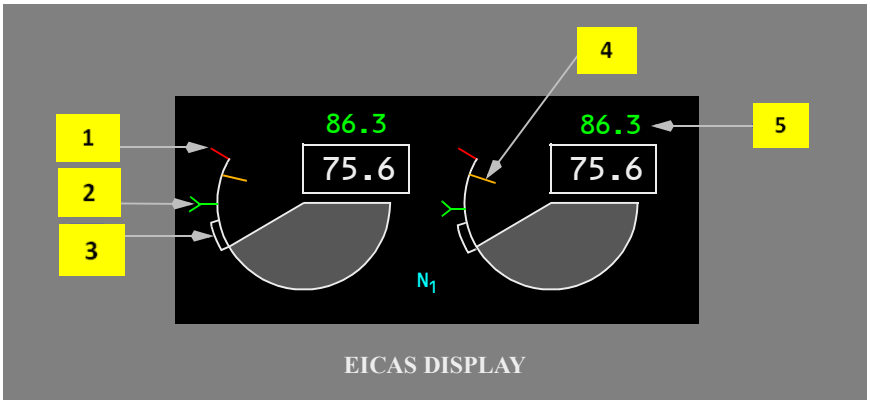

1 N1 Red Line

Displayed (red).

2 Reference/Target N1 Indication

Displayed (green) – reference N1 limit.

Displayed (magenta) – target FMC commanded N1 when VNAV is engaged and:

- the autothrottle is engaged in THR or THR REF mode, or
- the autothrottle is not engaged.

3 Commanded N1 Sector

Displays momentary difference between engine N1 and N1 commanded by thrust lever position.

4 Maximum N1 Line

Displayed (amber).

5 Reference N1

Displayed (green) – thrust reference calibrated for N1.

N1 Indications (All Modes)

[GE Engines]

Note: When reverse thrust is activated, the following indications are not displayed:

- maximum N1 line
- reference/target N1 indication
- commanded N1
- reference N1.

8 N1 Indication

N1 RPM, displayed:

- (white) – normal operating range
- displayed (red) – operating limit reached.

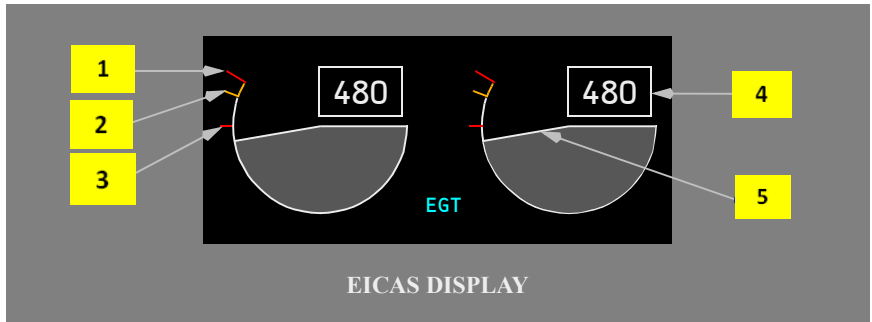
EGT Indications**1 EGT Red Line**

[GE, RR Engines]

Displayed (red) – maximum takeoff EGT limit.

1 EGT Red Line

[PW Engines]

Displayed (red) – maximum takeoff/in-flight start EGT limit.

2 EGT Amber Band

Displayed (amber) – maximum continuous EGT limit.

3 EGT Start Limit Line

[GE, RR Engines]

Displayed (red):

- with the FUEL CONTROL switch in CUTOFF, or

[GE Engines]

- with the N2 RPM below idle.

[RR Engines]

- with the N3 RPM below idle.

3 EGT Start Limit Line**[PW Engines]**

Displayed (red):

- on the ground
- with the FUEL CONTROL switch in CUTOFF, or
- with the N2 RPM below idle.

4 EGT

EGT (degrees C), displayed:

- (white) – normal operating range
- (amber) – maximum continuous limit reached
- (red) – maximum start or takeoff limit reached.

5 EGT Indication

Displayed:

- (white) – normal operating range
- (amber) – maximum continuous limit reached
- (red) – maximum start or takeoff limit reached.

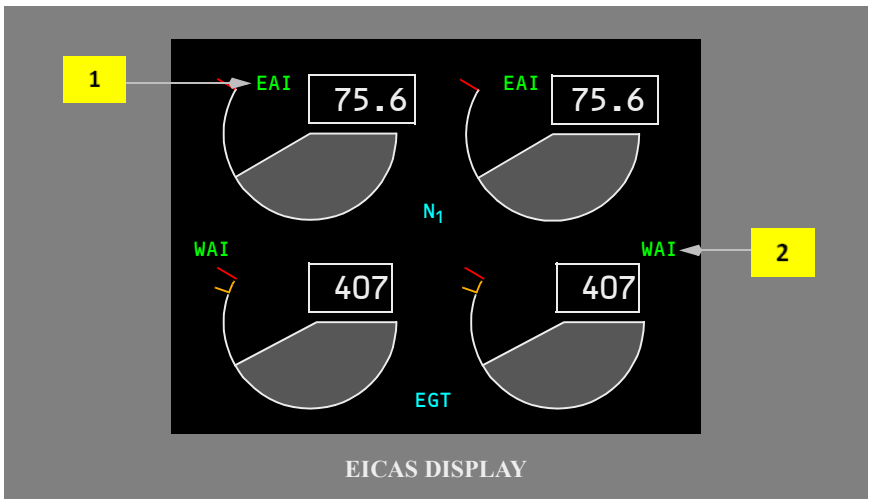
Anti-Ice Indications**1 Engine Anti-ice Indication**

Displayed (green) – engine anti-ice is on.

2 Wing Anti-Ice Indication

Displayed (green) – wing anti-ice is on.

In-Flight Start Envelope

[RR Engines]

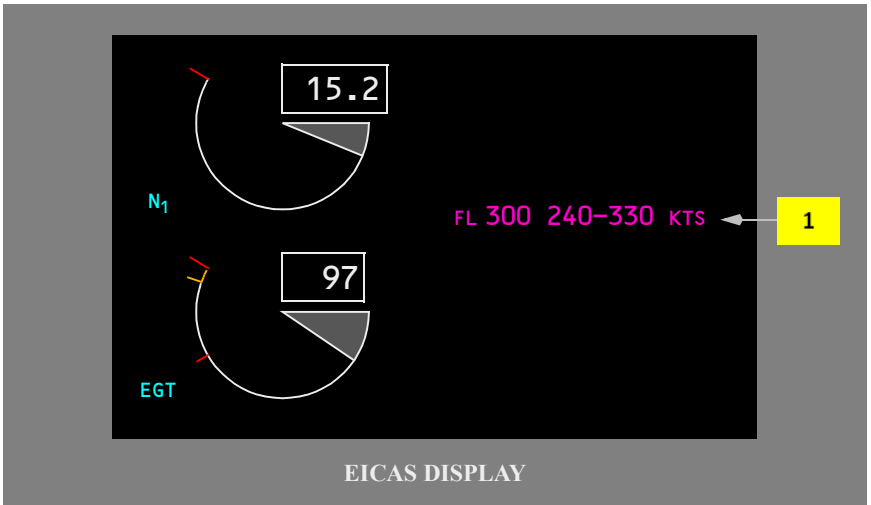

[PW engines]

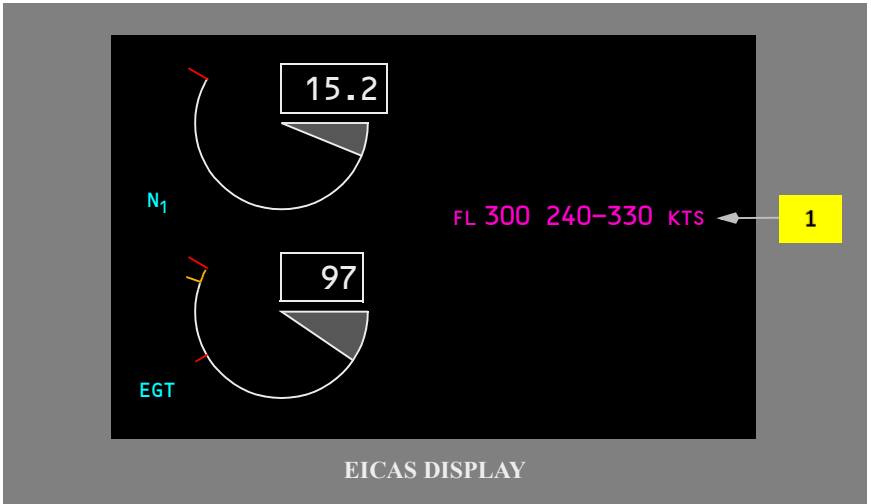

[GE Engines]

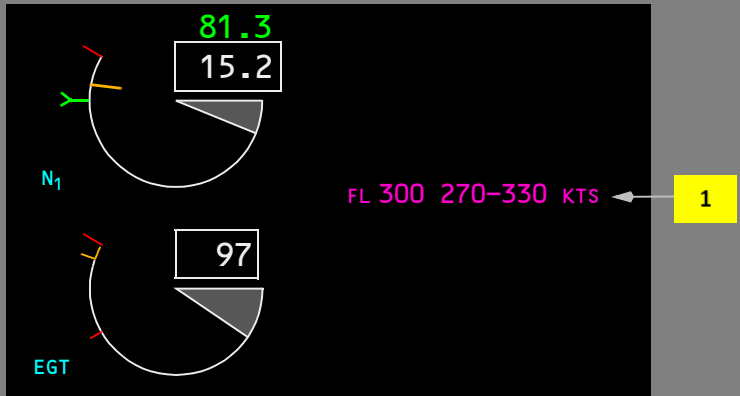

EICAS DISPLAY

1 In-Flight Start Envelope

Displayed (magenta) – airspeed range for an in-flight start at the current flight level or maximum flight level (whichever is less) when the respective engine fire switch is in and:

- a FUEL CONTROL switch is in CUTOFF, or

[PW, GE Engines]

- engine N2 RPM is below idle.

[RR Engines]

- engine N3 RPM is below idle.

Crossbleed Start Indications

[PW, GE Engines]

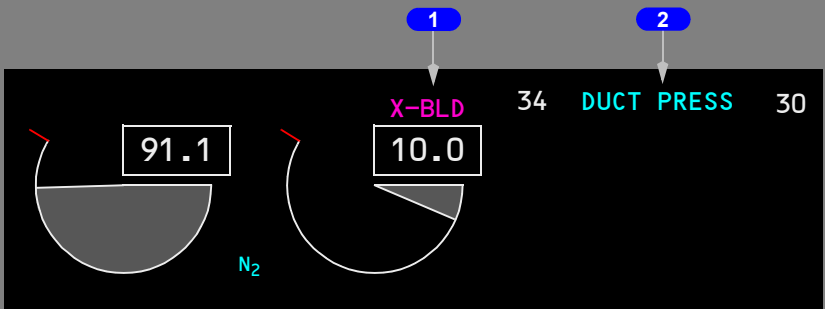

SECONDARY ENGINE DISPLAY

[RR Engines]

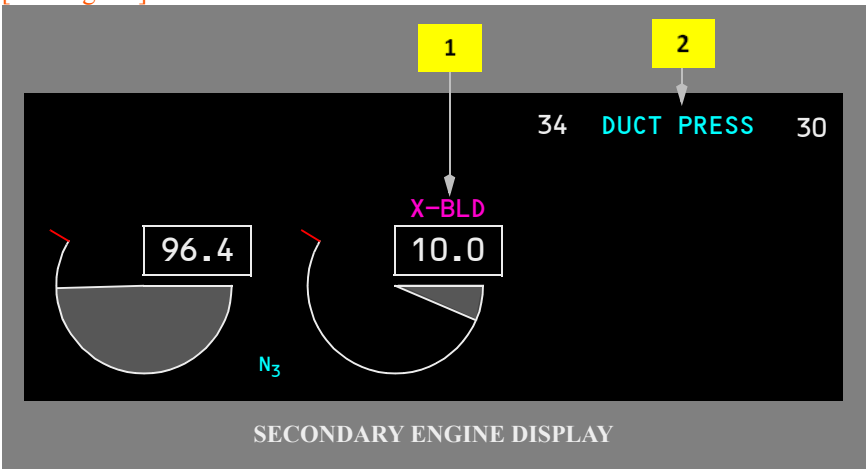

1 CROSSBLEED START Indication

Indicates crossbleed air is recommended for an in-flight start.

Displayed (magenta):

- the in-flight start envelope is displayed, and
- airspeed is lower than that for a windmilling start.

2 DUCT PRESSURE

Displayed (white numbers) – pressure in the left and right bleed air ducts in psi when the respective engine fire switch is in and:

- a FUEL CONTROL switch is in CUTOFF, and

[PW, GE Engines]

- engine N2 RPM is below idle.

[RR Engines]

- engine N3 RPM is below idle.

Secondary Engine Display

[Options – PW Engines, English Units]

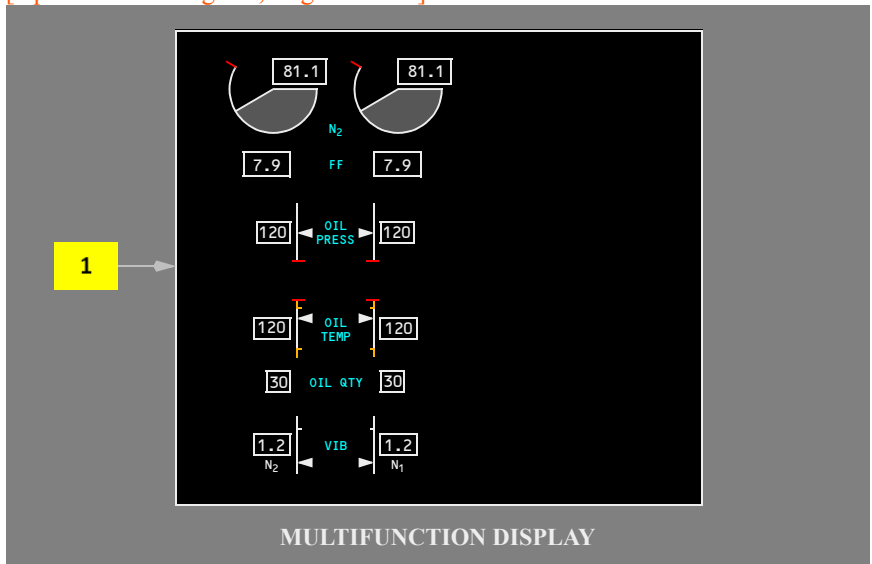

[Options – GE Engines, Metric Units]

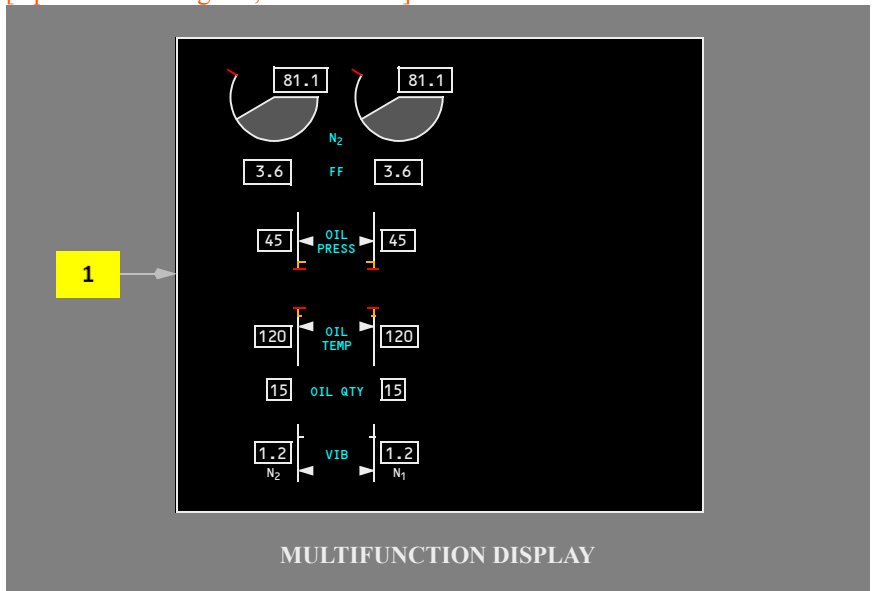

[Options – RR Engines, Metric Units]

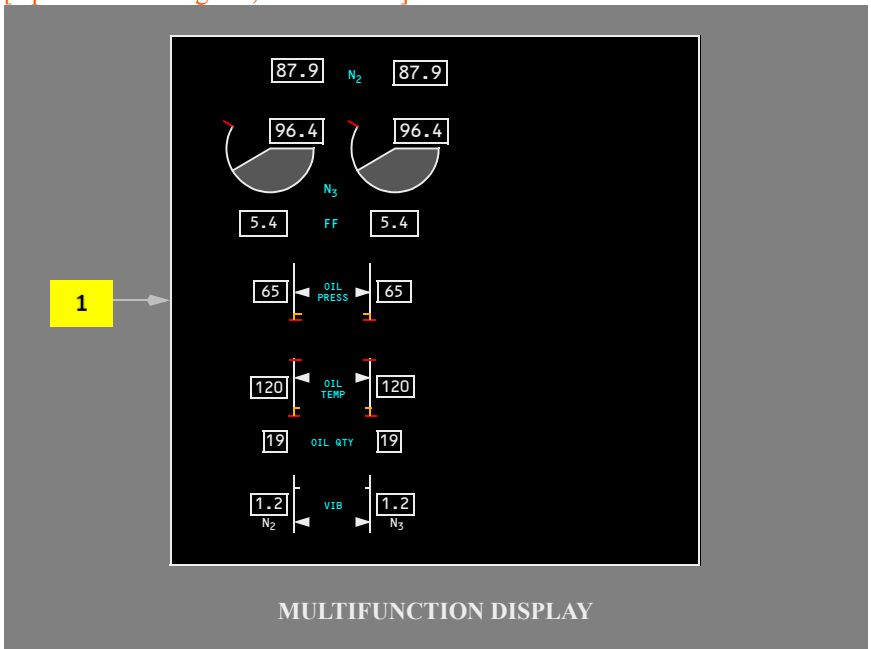

1 Secondary Engine Display

[PW, GE Engines]

Displays:

- N2 RPM
- fuel flow (FF)
- oil pressure
- oil temperature
- oil quantity
- vibration.

1 Secondary Engine Display

[RR Engines]

Displays:

- N2 RPM
- N3 RPM
- fuel flow (FF)
- oil pressure
- oil temperature
- oil quantity
- vibration.

N2 Indications

[PW, GE Engines]

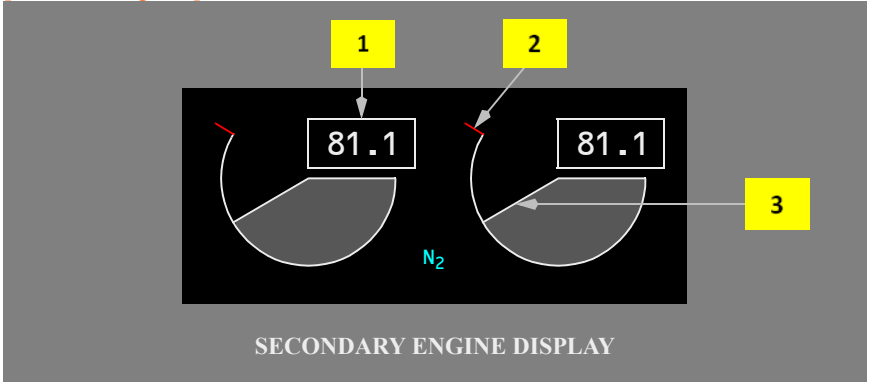

[RR Engines]

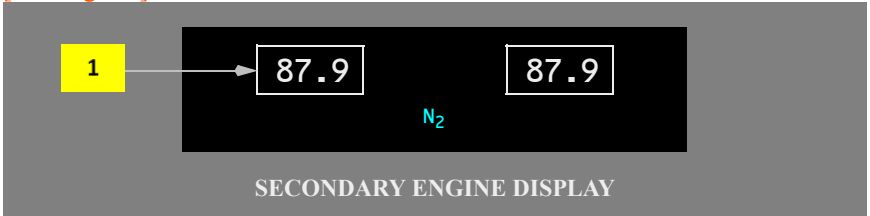

1 N2

N2 RPM (%), displayed:

- (white) – normal operating range
- (red) – operating limit reached.

2 N2 Red Line

N2 RPM operating limit, displayed (red).

3 N2 Indication

N2 RPM, displayed:

- (white) – normal operating range
- (red) – operating limit reached.

N3 Indications

[RR Engines]

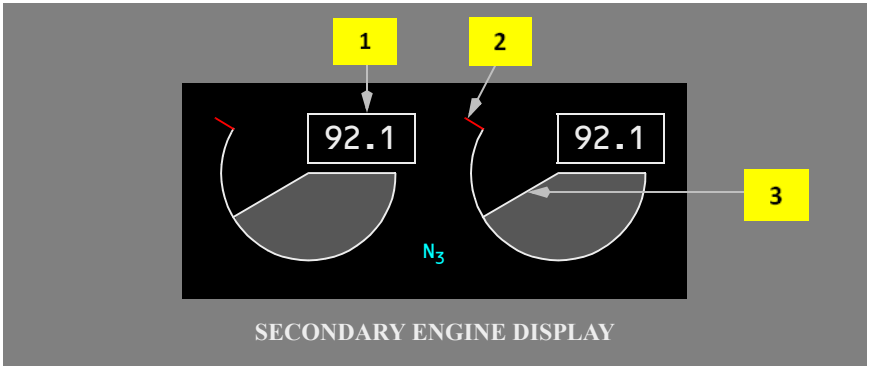

1 N3

N3 RPM (%), displayed:

- (white) – normal operating range
- (red) – operating limit reached.

2 N3 Red Line

N3 RPM operating limit, displayed (red).

3 N3 Indication

N3 RPM, displayed:

- (white) – normal operating range
- (red) – operating limit reached.

Fuel Flow Indications

[Option – English Units]

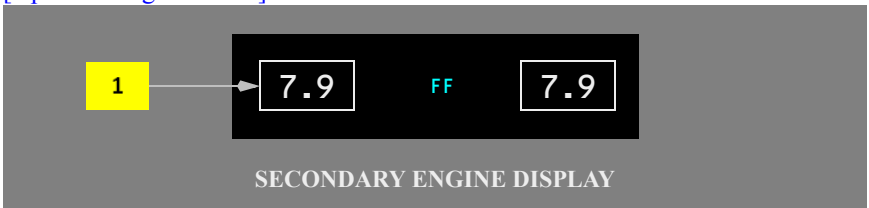

[Option – Metric Units]

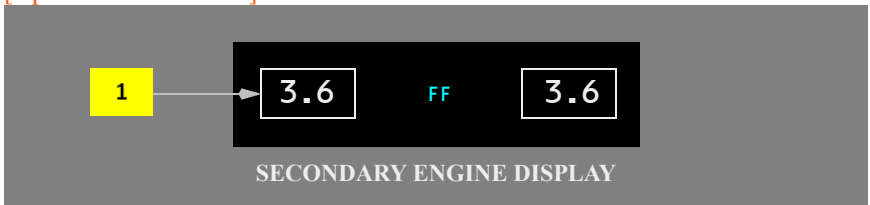

1 Fuel Flow

[English Units]

Displayed (white) – fuel flow to the engine (pounds per hour x 1000).

[Metric Units]

Displayed (white) – fuel flow to the engine (kilograms per hour x 1000).

Oil Pressure Indications

[PW Engines]

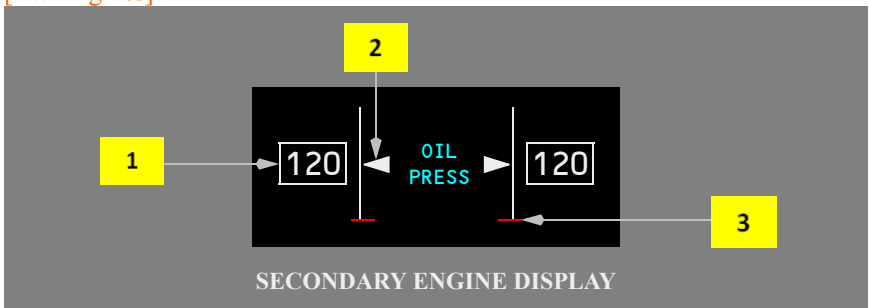

[GE, RR Engines]

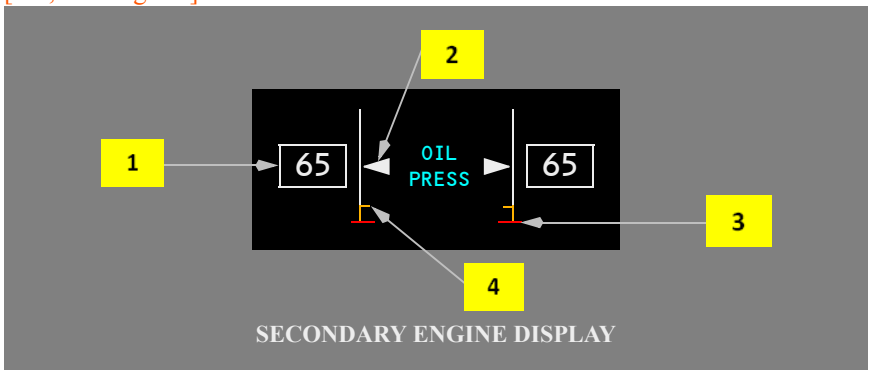

1 Oil Pressure

[PW Engines]

Engine oil pressure (psi), displayed:

- (white) – normal operating range
- (red) – operating limit reached.

2 Oil Pressure

[GE, RR Engines]

Engine oil pressure (psi), displayed:

- (white) – normal operating range
- (amber) – caution range reached
- (red) – operating limit reached.

2 Oil Pressure Pointer

[PW Engines]

Engine oil pressure, displayed:

- (white) – normal operating range
- (red) – operating limit reached.

2 Oil Pressure Pointer

[GE, RR Engines]

Engine oil pressure, displayed:

- (white) – normal operating range
- (amber) – caution range reached
- (red) – operating limit reached.

3 Oil Pressure Red Line

Displayed (red) – oil pressure operating limit.

4 Oil Pressure Amber Band

[GE, RR Engines]

Displayed (amber) – oil pressure caution range.

Oil Temperature Indications

[PW Engines]

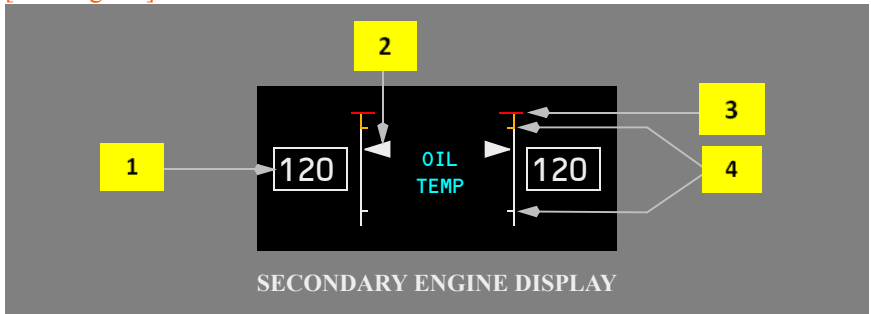

[GE Engines]

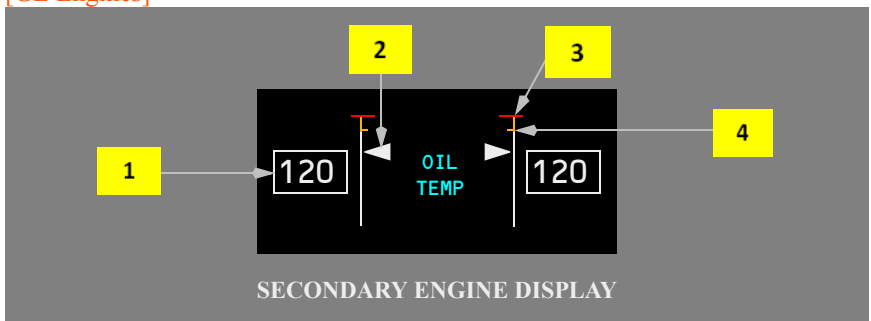

[RR Engines]

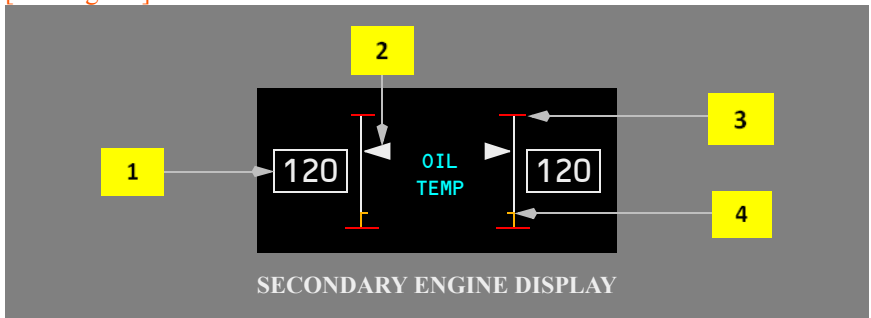

1 Oil Temperature

Engine oil temperature (degrees C), displayed:

- (white) – normal operating range
- (amber) – caution range reached
- (red) – operating limit reached.

2 Oil Temperature Pointer

Engine oil temperature, displayed:

- (white) – normal operating range
- (amber) – caution range reached
- (red) – operating limit reached.

3 Oil Temperature Red Line

Displayed (red) – oil temperature operating limit.

4 Oil Temperature Amber Band

Displayed (amber) – oil temperature caution range.

Oil Quantity Indications

[English Units]

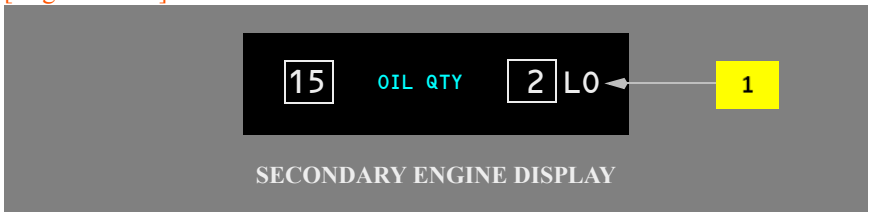

[Metric Units]

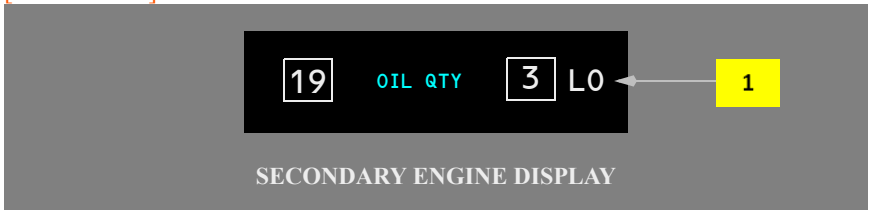

1 Oil Quantity

[English Units]

Usable oil quantity (quarts).

[Metric Units]

Usable oil quantity (liters).

Displayed:

- (white) – normal quantity
- (reverses the display to show black numbers on white background) – low quantity.

Note: LO – displayed (white) when quantity is low.

Engine Vibration Indications

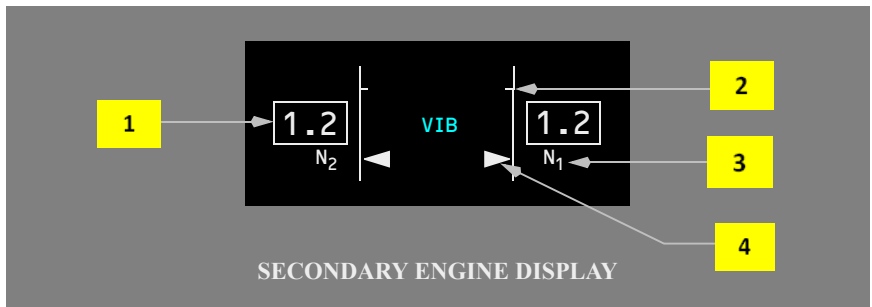

1 Engine Vibration

Engine vibration, displayed:

- (white) – normal operating range
- (black numbers, white background) – high vibration.

2 Engine Vibration High Band

Displayed (white) – vibration level at which automatic display of secondary engine indications occurs.

3 Vibration Source

Identifies the vibration source being displayed.

Displayed (white) – vibration source with the highest vibration:

- N1 rotor vibration
- N2 rotor vibration.

[RR Engines]

- N3 rotor vibration.

If the vibration source BB (broad band vibration) is displayed, the source is unknown and average vibration is displayed.

4 Engine Vibration Pointer

Displayed (white) – engine vibration.

Compact Engine Indications

[Options – PW Engines, English Units]

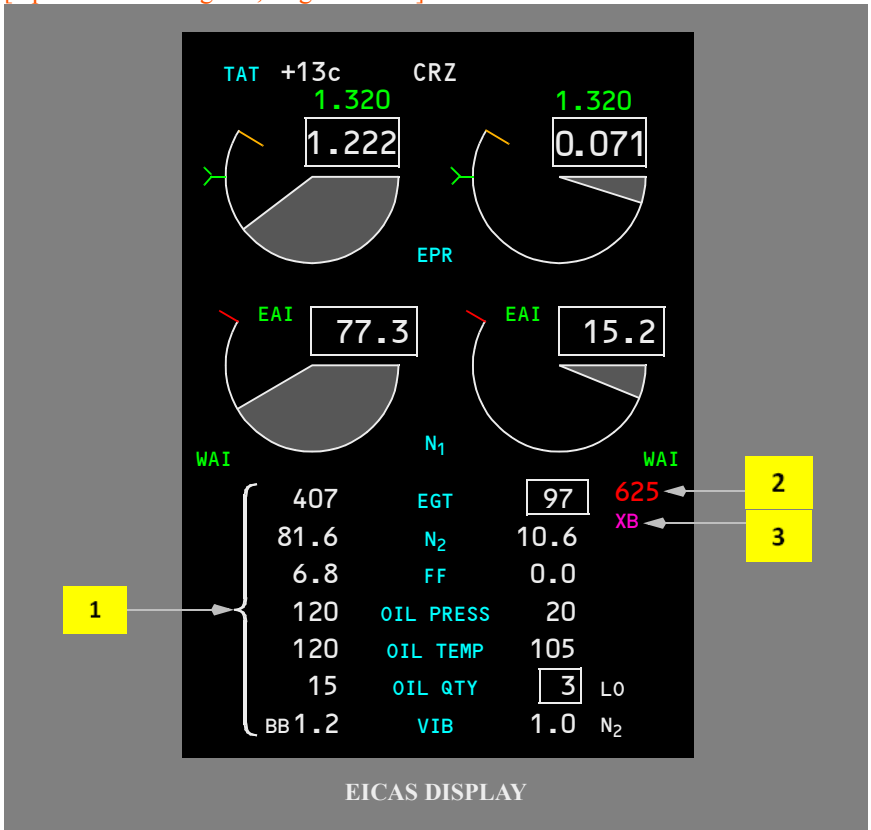

[Options – GE Engines, Metric Units]

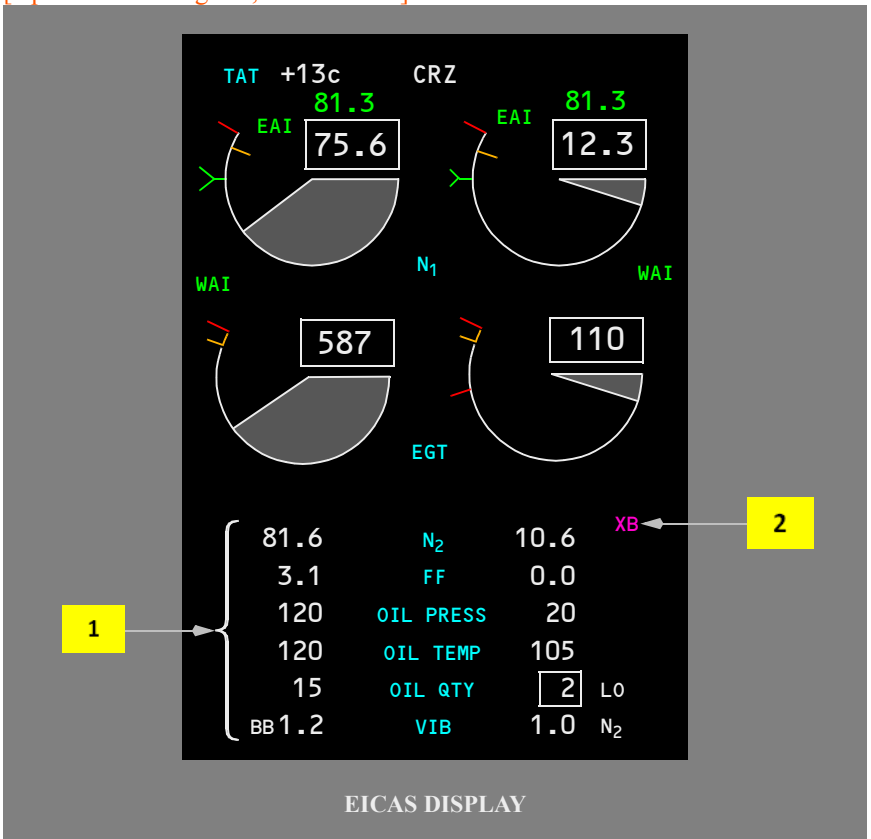

[Options – RR Engines, Metric Units]

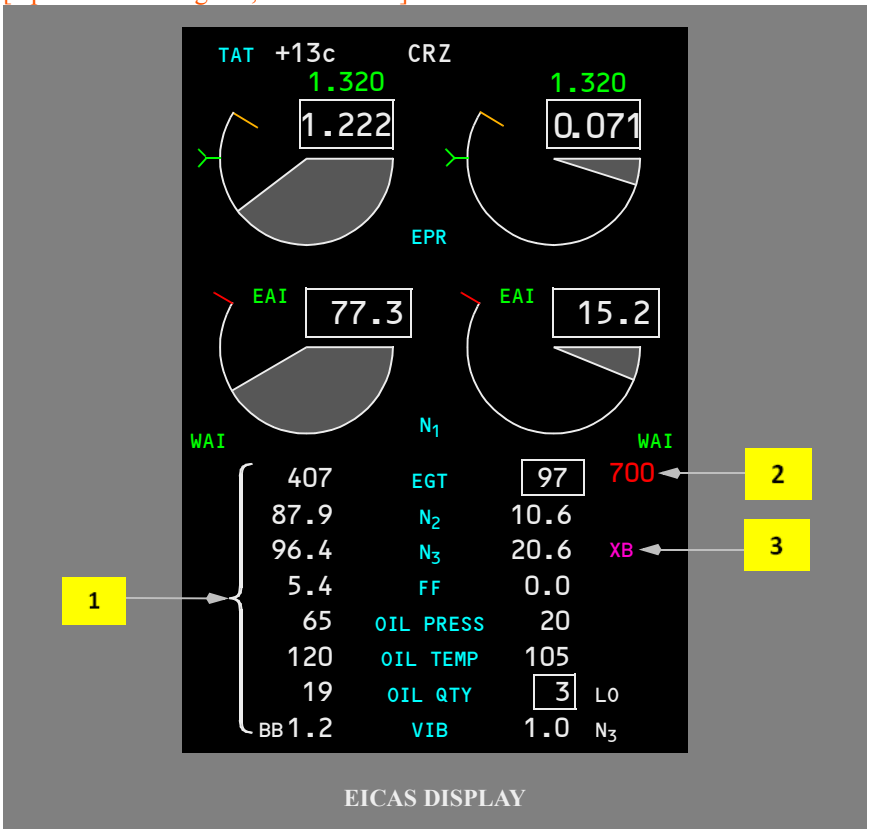

1 Compact Engine Indications

The following changes to EICAS and the normal secondary engine display occur:

[GE Engines]

- N₂ changes from round dial displays to a digital display. The digital display is framed by an amber or red box if limits are exceeded.

[PW Engines]

- EGT and N₂ change from round dial displays to digital displays. The digital displays are framed by an amber or red box if limits are exceeded.

[RR Engines]

- EGT and N₃ change from round dial displays to digital displays. The digital displays are framed by an amber or red box if limits are exceeded.

- FF, OIL PRESS, OIL TEMP are displayed as digital readouts only. The digital displays turn amber or red if limits are exceeded.
- OIL QTY and VIB are displayed as digital readouts only. Low oil quantity and high vibrations are displayed the same as in the normal format.

2 Crossbleed start indication

Displayed (magenta).

3 EGT start limit

[PW, RR Engines]

Displayed (red).

Engine Controls

Thrust Levers

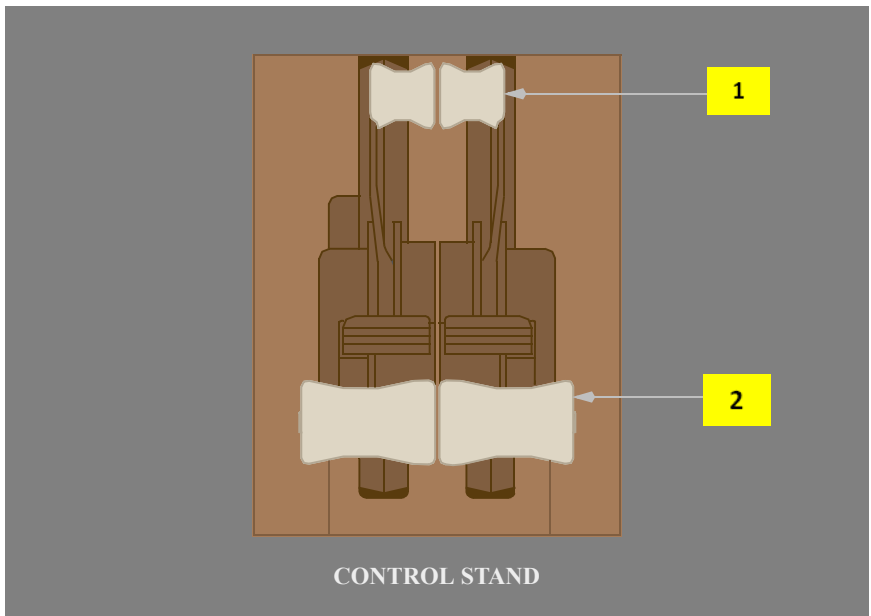

1 Reverse Thrust Levers

Control engine reverse thrust.

Reverse thrust can only be selected when the forward thrust levers are closed.

Actuates automatic speedbrakes

2 Forward Thrust Levers

Controls engine forward thrust.

The thrust levers can only be advanced if the reverse thrust levers are down.

Fuel Control Switches

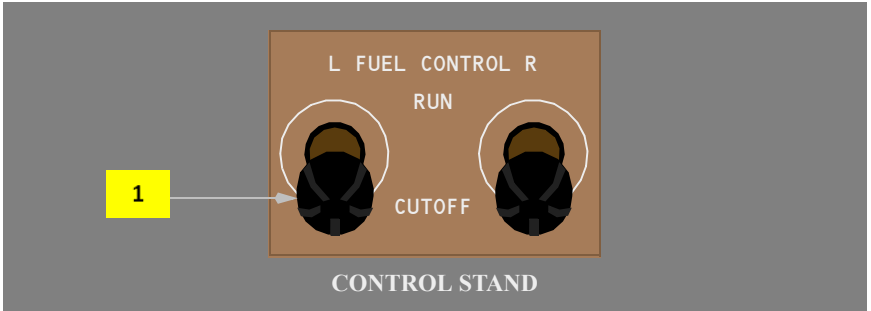

1 FUEL CONTROL Switch

RUN (AUTOSTART ON) –

- Opens the spar fuel valve
- arms the engine fuel valve (the EEC opens the valve when required)
- arms the selected ignitors(s) (the EEC turns the ignitors on when required).

RUN (AUTOSTART OFF) –

- opens the spar fuel valve
- opens the engine fuel valve
- turns ignitors on.

CUTOFF –

- closes the fuel valves
- removes ignitor power
- unlocks the engine fire switch.

Engine Control Panel

[PW, GE Engines with CON IGN position]

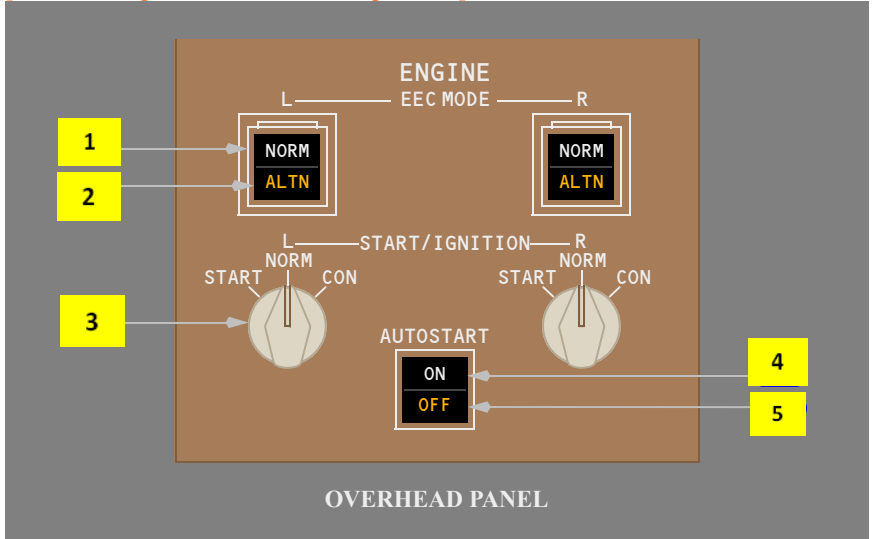

[RR Engines, GE Engines without CON IGN position]

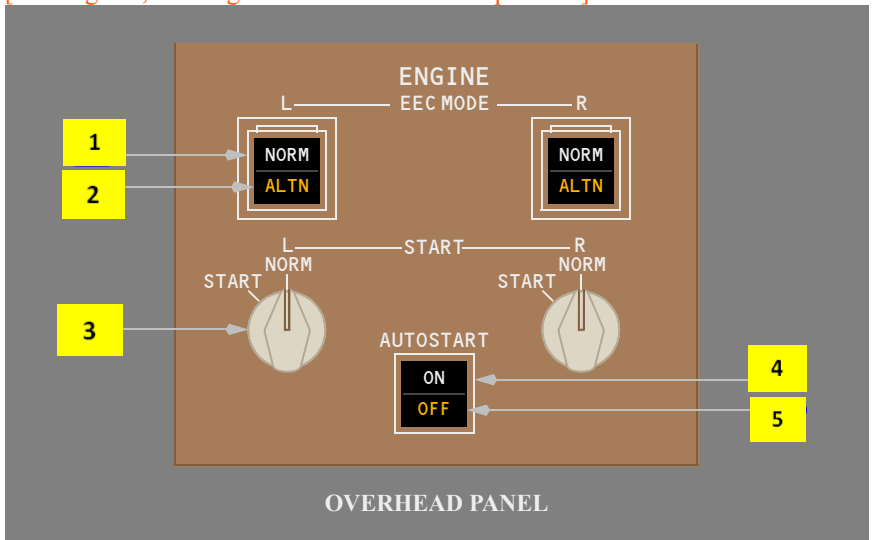

1 Electronic Engine Control (EEC) Mode Switch

NORM –

- selects the normal engine control mode for engine control
- **[GE Engines]**
 - the EEC sets thrust using N1 RPM as the controlling parameter.
- **[PW, RR Engines]**
 - the EEC sets thrust using EPR as the controlling parameter.

Off (ALTN visible) –

- selects the alternate engine control mode for engine control
- thrust is set using N1 RPM as the controlling parameter.

2 Electronic Engine Control (EEC) Alternate (ALTN) Light

Illuminated (amber) – the alternate engine control mode is either automatically or manually selected.

3 START/IGNITION Selector

[PW Engines]

START –

- initiates engine start by opening the start valve
- releases to NORM at start valve cutout.

NORM –

- the start valve closes
- automatic ignition is provided for both ignitors (if the FUEL CONTROL switch is in RUN)
- automatic ignition operates both ignitors continuously for the following conditions:
 - the flap lever is out of the up position, or
 - engine anti-ice is on.

CON – both ignitors operate continuously (if the FUEL CONTROL switch is in RUN).

3 START/IGNITION Selector

[GE Engines with CON IGN position]

START –

- initiates engine start by opening the start valve
- releases to NORM at start valve cutout.

NORM –

- the start valve closes
- ignition is automatically provided during engine start-up or if engine flameout occurs (if the FUEL CONTROL switch is in RUN).

CON – both ignitors operate continuously (if the FUEL CONTROL switch is in RUN).

3 START Selector

[RR Engines]

START –

- initiates engine start by opening the start valve
- releases to NORM at start valve cutout.

NORM – the start valve closes.

4 AUTOSTART Switch

ON – arms the autostart system.

OFF –

- the autostart system is disabled
- the start is manually controlled.

5 AUTOSTART OFF Light

Illuminated (amber) – the AUTOSTART switch is OFF.

Auxiliary Power Unit (APU)

APU Controls

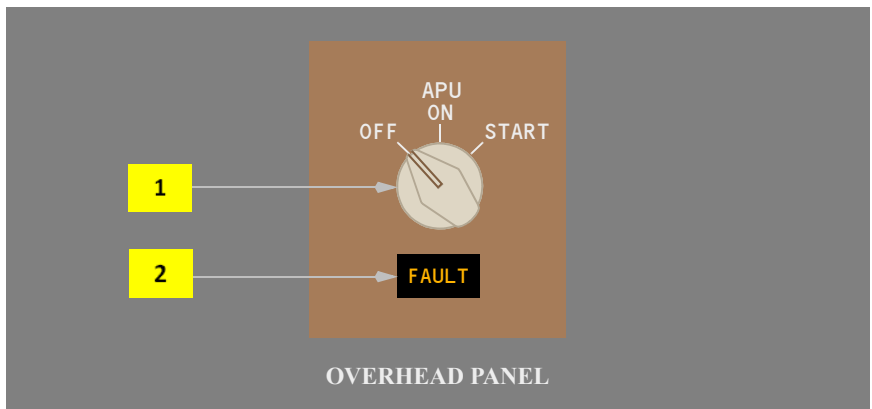

1 APU Selector

OFF –

- closes the APU bleed air isolation valve
- initiates normal shutdown
- resets auto shutdown fault logic.

ON (APU operating position –

- opens the APU fuel valve and inlet door
- activates AC or DC fuel pump
- powers the APU controller.

START (momentary position, spring-loaded to ON) – initiates automatic start sequence.

2 APU FAULT Light

Illuminated (amber):

- APU fault and/or fire is detected
- APU shutdown due to fault and/or fire
- momentarily during APU controller self-test.

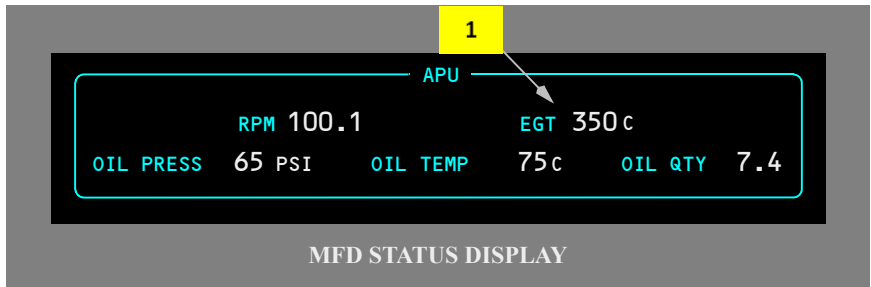
APU Indications**1 APU Status Display**

RPM – APU rotation speed in percent RPM.

EGT – APU exhaust gas temperature.

OIL PRESS – APU oil pressure in PSI.

OIL TEMP – APU oil temperature.

[English Units]

OIL QTY – APU oil quantity (quarts).

[Metric Units]

OIL QTY – APU oil quantity (liters).